



TransGrid transmission determination 2018–23

April 2018

Attachment B
Pricing Methodology



TransGrid

TransGrid Pricing Methodology

2018/19 – 2022/23

Leveraging more than 60 years infrastructure excellence, our network is the centrepiece of the National Electricity Market. Providing interconnection capability to Victoria and Queensland and playing a crucial role in supporting the economic growth of NSW and the ACT – TransGrid is one of the most reliable transmission networks in the world.

“Our vision is for TransGrid to lead Australia’s transformation to a low carbon future.”



Paul Italiano
Chief Executive Officer
October 2016

Objective

TransGrid and its partners are contributing to the transformation of Australia's energy system to one that is smarter and cleaner.

TransGrid is committed to be at the forefront of providing innovative, effective energy solutions to our customers to further enable an efficient, sustainable and competitive electricity industry.

TransGrid understands renewable generation is the future for a low carbon economy. This journey starts with a reliable transmission service to deliver power to the market.

Combining our strong relationships with government and communities with our technical expertise, we've been responding to customer feedback, and reducing the cost of network services.

This document sets out how TransGrid will ensure transmission prices are as efficient as possible and calculated in accordance with the National Electricity Rules.

Contents

1.	Introduction.....	5
1.1	Pricing methodology objectives.....	5
1.2	Pricing methodology features.....	5
2.	Duration.....	6
3.	Which services are subject to this pricing methodology?.....	6
3.1	Terms used in this document.....	7
4.	Overview of the pricing methodology.....	8
5.	Allocation to transmission services.....	9
5.1	Aggregate annual revenue requirement.....	9
5.2	Annual service revenue requirement.....	9
5.3	Worked example of allocation to transmission services.....	10
6.	Allocation to connection point.....	11
6.1	Worked examples for entry, exit and common services.....	11
6.2	Shared network services.....	12
6.2.1	Adjustments to the shared network revenue to be recovered.....	12
6.2.2	Application of the Cost Reflective Network Pricing methodology.....	13
6.2.3	Modified Cost Reflective Network Pricing methodology.....	14
7.	Set transmission pricing structures.....	14
7.1	Entry and exit services charges.....	15
7.2	Locational charges.....	16
7.3	Non-locational charges.....	16
7.4	Prescribed common service charges.....	17
7.5	Publication of transmission prices.....	17
7.6	Setting of locational prices between annual price publications.....	17
8.	Billing arrangements.....	17
8.1	Billing for prescribed transmission services.....	17
8.2	Payments between Transmission Network Service Providers in the same region.....	18
9.	Prudential requirements.....	18
9.1	Prudential requirements for prescribed transmission services.....	18
9.2	Capital contribution or prepayment for a specific asset.....	18
10.	Prudent discounts.....	19
11.	Inter-regional transmission charging.....	19
11.1	Overview of the process.....	19
11.2	Timetable for the provision of data.....	20
11.3	Billing the modified load export charge.....	21

11.4	Billing arrangements between multiple TNSPs in a region	21
11.4.1	Allocation of amounts to each TNSP in the same region	21
11.4.2	Billing each TNSP in the same region	21
11.5	Worked example – modified load export charge.....	22
11.6	Worked example – allocation and billing to other TNSPs in NSW region	23
12.	Monitoring and compliance.....	24
13.	Description of pricing methodology differences	24
Appendix A – Cost Reflective Network Pricing methodology		25
Appendix B – Calculating utilisation factors		27
Appendix C – Priority ordering methodology		28

Figures

Figure 1:	Representation of pricing structure	8
Figure 2:	MLEC calculation overview	19
Figure 3:	MLEC data provision timetable	21

Tables

Table 1:	Pricing methodology objectives.....	5
Table 2:	Derivation of AARR to be allocated to the four services	10
Table 3:	Asset allocations to service categories	10
Table 4:	Asset Values employed at each entry point	11
Table 5:	Exit service revenue allocation to each exit point	12
Table 6:	Common service revenue allocation to each exit point.....	12
Table 7:	Transmission Pricing Structure	15
Table 8:	Standard CRNP allocation and Interconnector cost share	22
Table 9:	Modified load export charge	23
Table 10:	CRNP allocation and percentage of total, on a TNSP basis.....	23
Table 11:	Calculation of MLEC attributed to each TNSP in the NSW region	24

1. Introduction

This document sets out TransGrid's proposed pricing methodology for transmission services during the 2018/19 – 2022/23 regulatory period. This pricing methodology has been drafted in compliance with the relevant provisions of Chapter 6A of the National Electricity Rules (the Rules) and, the Australian Energy Regulator's (AER) pricing methodology guidelines which are relatively prescriptive. The level of electricity prices is a separate matter to the pricing methodology for transmission services. The pricing methodology is used to allocate the transmission network businesses revenue allowances, determined by the AER, between customers.

TransGrid is the Co-ordinating Network Service Provider (CNSP) for the New South Wales market region. This means that TransGrid applies its pricing methodology to determine the transmission prices that are to be charged in the New South Wales market region to recover the regulated transmission revenues of Ausgrid, Directlink, ActewAGL and TransGrid in accordance with Rule 6A.29.

This pricing methodology will be submitted to the AER by 31 Jan 2017 as part of the Revenue Proposal package for approval and will apply from 1 July 2018. Subject to approval, it is intended to replace the current approved pricing methodology submitted to the AER on 13 January 2015 and takes into account feedback received from our customers during the 2016 customer engagement program. Following a review of the pricing methodology objectives and operation, as well as consultation with customers, no changes have been proposed from the current methodology; however, the document has been revised to improve readability. Ensuring TransGrid's approach to setting prices is clear and easy for customers to understand was an important priority identified in consultation.

1.1 Pricing methodology objectives

Through TransGrid's consultation with stakeholders the pricing methodology objectives in Table 1 were identified.

Table 1: Pricing methodology objectives

Objective	Description
Price Stability	Minimise customer price variation and moderate price signals to avoid inefficient usage decisions
Price Signals	Provide appropriate price signals to customers to encourage efficient use of the network
Responsiveness	Customers understand how prices are set and are able to respond to price signals
Equity	Prices reflect customers use of the transmission system and allocates costs equitably between customers
Efficiency	Prices reflect the efficient costs of providing network service

1.2 Pricing methodology features

TransGrid consulted closely with customers, large energy users and consumer representatives before submitting the current pricing methodology to the AER in 2014.

Customers provided three pieces of consistent feedback:

1. make transmission pricing more cost reflective
2. reduce the common service and non-locational proportion of transmission charges
3. charges should be based on demand rather than energy

Changes implemented in the current period to address this feedback were strongly supported by customers:

- > move from standard Cost Reflective Network Pricing (CNRP) to modified CRNP; this addresses points 1 and 2 above
- > move to maximum demand from energy for non-locational and common services pricing; this addresses point 3 above

The following features of the current methodology have been assessed and TransGrid considers these features should be retained in the next period pricing methodology as we believe they continue to be aligned with stakeholder objectives:

- > **Non-locational and Common Service Price:** Continue to use historical annual maximum demand as the basis of calculating the non-locational and common service prices, which provides price signals to customers that are closely aligned to TransGrid's investment drivers.
- > **Locational Charge - Maximum Demand Based Prices:** Continue to use forecast monthly maximum demand as the basis of calculating the locational prices and actual monthly maximum demand for charging which provides price signals to customers.
- > **Locational Charge - Equitable Determination of Network Utilisation:** Continue to allocate system costs using cost reflective network pricing on a 365 day basis, as this results in a more equitable outcome for customers than a 10 day peak basis.
- > **Modified Cost Reflective Network Pricing:** Continue to calculate the locational price using Modified Cost Reflective Network Pricing (MCRNP) using utilisation adjusted replacement costs to adjust the amounts recovered from locational and non-locational charges, and to provide utilisation adjusted cost reflective price signals.
- > **Existing price structure:** Continue to use the current price structure and components for the 2018/19-2022/23 pricing methodology with continued use of the industry standard TPRICE software.

There are a number of emerging changes to the energy and demand patterns for electricity consumers in the NSW and ACT market region that could impact the type of transmission services provided by TransGrid looking out to 2035. These are the effects of energy efficiency, embedded small generation (such as solar PV) and electric vehicles. TransGrid actively monitors and has considered these emerging changes for impacts on the effectiveness of the pricing methodology in the next regulatory period. This is done to ensure that any change to the pricing approach is transitioned over time to avoid major price shocks to customers.

2. Duration

This pricing methodology will apply from 1 July 2018 of the 2018/19 - 2022/23 regulatory period.

3. Which services are subject to this pricing methodology?

TransGrid's pricing methodology applies to transmission services provided by a Transmission Network Service Provider (TNSP) in the NSW market region, this typically includes all services to transport electricity from generation to major load centres, after that point the distribution services take over to deliver the electricity to homes and businesses in NSW and the ACT. The four service categories are:

- > **Shared network services** as set out in the Rules which are provided to large customers and distribution companies. These are defined as Locational and Non-locational
- > **Exit services**, connection services provided to large customers and distributors. These are specific connection costs for each customer reflecting the assets used to support the connection
- > **Entry services**, connection services are provided to generators. These are specific connection costs for each generator reflecting the assets used to support the connection

- > **Common services**, which are services that provide the same benefit to all load customers irrespective of their location. Covers the costs of services that benefits all customers, ie, specific types of assets such as reactive plant that are not dedicated to a single connection point

Full definitions of the transmission service categories are set out in Chapter 6A of the Rules.

In addition to these regulated or “prescribed” transmission services, TransGrid also provides negotiated and non-prescribed transmission services. Some connection services are negotiated services, for example new generation connections. These negotiated and non-prescribed services are not subject to this pricing methodology, for further information on these services, please refer to our negotiating framework.

3.1 Terms used in this document

Term	Definition
National Electricity Rules (Rules)	Rules exist so that market participants understand their rights and responsibilities, and there is appropriate regulation so that consumers do not pay more than necessary for their electricity. The Rules are made under the National Electricity Law and have the force of law
AARR (Annual Aggregate Revenue Requirement)	The maximum allowable revenue per year determined by the Australian Energy Regulatory (AER) adjusted by a revenue smoothing factor, CPI and performance incentive schemes as defined in the Rules
Standard CRNP (Cost Reflective Network Pricing)	A method for calculating locational transmission prices under the Rules, based on historical peak usage to allocate existing investment costs
Modified CRNP	A method for calculating locational transmission prices under the Rules, based on network usage and capacity. Increases the locational price as the utilisation of the transmission elements increases
Modified Load Export Charge (MLEC)	Transmission charging arrangement to reflect the benefits transmission provides in supporting energy flows between regions. This charge is also sometimes known as IR-TUOS
Connection Point	A point at which a transmission network, direct connect customer, generator or distribution network meet
Optimised Replacement Cost (ORC)	Cost of equivalent modern assets required to provide the current customer service requirements
Annual Service Revenue Requirement (ASRR)	The annual aggregate revenue requirement allocated to each transmission service
Settlement Residue Distribution (SRD)	This is a commercial arrangement between AEMO and a Market Customer, a Generator or a Trader as defined in NER Clause 3.18.2
Element	A collection of assets eg, lines, circuit breakers, capacitors, buses and transformers that provide a transmission service. Also known as a network pricing branch
Transmission Network User	In relation to a transmission network, a Transmission Customer, a Generator whose generating unit is directly connected to the transmission network or a Network Service Provider whose network is connected to the transmission network

4. Overview of the pricing methodology

This pricing methodology is concerned with allocating the regulated transmission revenue of TNSP's in NSW and ACT between customers through the setting of transmission prices for each connection point in the region. This is illustrated in Figure 1 below.

Step 1: Allocation to transmission services

- > Allocating the appropriate amount of revenue to be recovered to each of the four transmission service categories - entry, exit, shared network and common service.

Step 2: Allocation to connection points

- > Calculating the amount of revenue to be recovered from each of the TNSP's connection points in the NSW market region; and

Step 3: Set transmission pricing structures

- > Setting prices at each of those connection

Figure 1: Representation of pricing structure

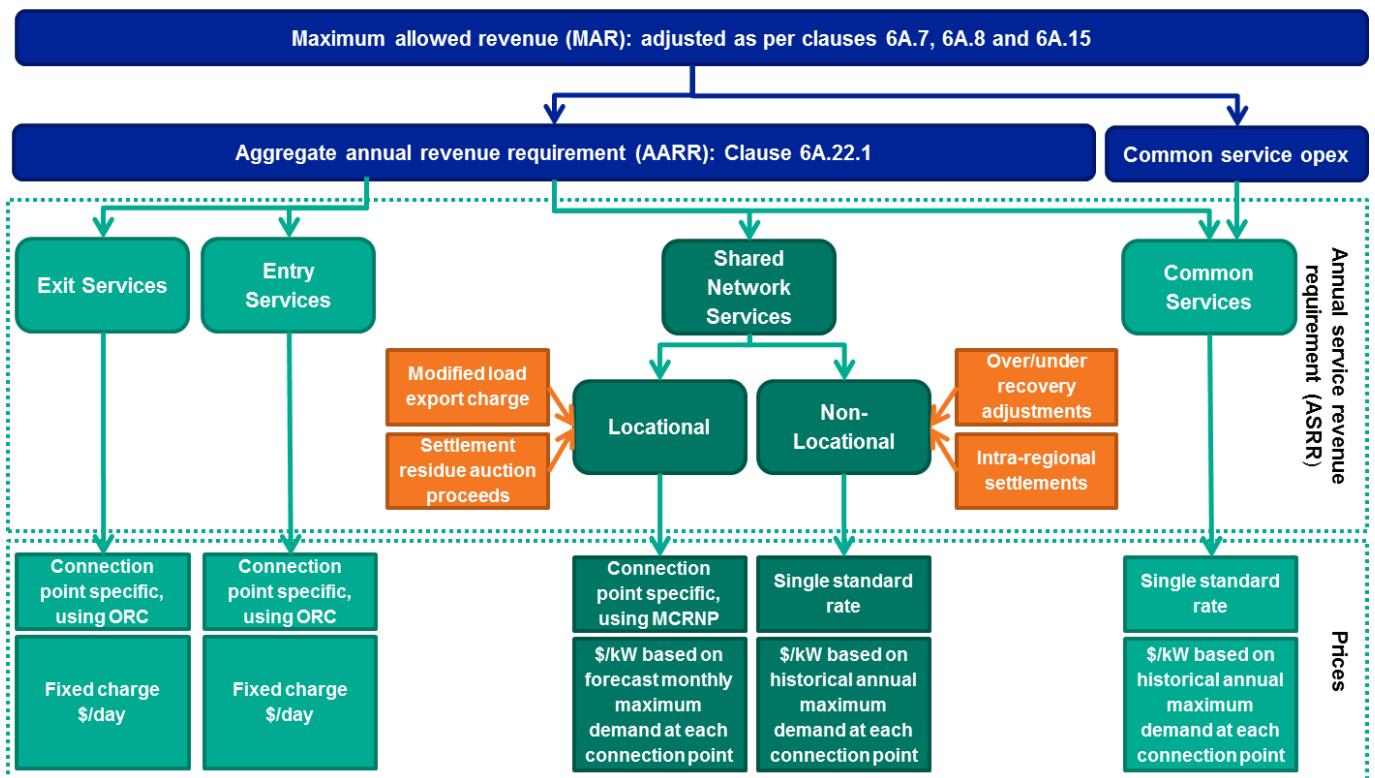

In Figure 1 the blue boxes indicate the allowed revenue, green boxes indicate the share of AARR allocated by service and the orange boxes are revenue adjustments as required under the Rules.

5. Allocation to transmission services

5.1 Aggregate annual revenue requirement

The Rules define the revenue to be recovered from transmission prices as the aggregate annual revenue requirement (AARR). This is different to the maximum allowed revenue (MAR) set by the AER because it may include a number of adjustments, such as:

- > Reopening of revenue determination for capital expenditure (Rule 6A.7.1)
- > Reopening or revocation of the revenue determination (Rule 6A.15)
- > Network support pass through (Rule 6A.7.2)
- > Cost pass through (Rule 6A.7.3)
- > Small scale incentive scheme (Rule 6A.7.5)
- > Service target performance incentive scheme (Rule 6A.7.4)
- > Contingent projects (Rule 6A.8.2)

It should be noted that some of these potential adjustments are very rare, for example, the re-opening of the revenue determination. Others, at this time are not applicable, for example no small scale incentive scheme has been devised by the AER. However, others such as the service target performance incentive scheme are expected to occur in most years.

In addition to these adjustments, the Rules require the operating and maintenance costs expected to be incurred in the provision of prescribed common services to be allocated directly to common services, and recovered through common service prices (Rule 6A.22.1(2)). The operating expenditure that TransGrid attributes to common services is derived from forecasts of

- > Network switching and operations
- > Administration and management of the business
- > Network planning and development
- > General overheads

As the co-ordinating network service provider TransGrid is responsible for allocating the AARR for the NSW region under Clause 6A.29.3, which covers NSW and the ACT. Each transmission network service provider in the NSW market region is required to calculate its own AARR and advise TransGrid as required by Clause 6A.29.1(b) and 6A.29.1(e).

5.2 Annual service revenue requirement

The first step in calculating transmission prices is to determine how to allocate regulated revenue between the four transmission service categories.

Transmission assets are allocated to each service category and the revenue requirement (net of the operating and maintenance costs allocated directly to common services) is then allocated to each service category to reflect the percentage of the total asset costs that is attributed to that service.

Clause 2.4 of the AER's pricing methodology guidelines explains how assets should be attributed to the different prescribed transmission service categories. For example, the AER's guidelines state that the types of transmission system assets that are directly attributable to entry services are limited to:

- > Substation buildings, substation land and associated infrastructure (such as fences, earthing equipment etc)
- > Switchgear and plant associated with generators' generating systems connection and generator transformers
- > Secondary systems associated with primary systems providing prescribed entry services

- > Transmission lines owned by transmission network service providers (TNSPs) connecting generators' generating systems to the TNSP's transmission network
- > Meters associated with prescribed entry services and owned by the TNSP

The AER provides similar guidance in relation to exit services, shared network services and common services. TransGrid's pricing methodology adopts an allocation approach which is consistent with the AER's guidelines.

In cases where assets could be attributable to more than one category of transmission service, the Rules provide a mechanism for determining the appropriate allocation in Clause 6A.23.2(d). Further information on this priority ordering process is provided in Appendix C.

5.3 Worked example of allocation to transmission services

The following table provides an illustrative example of how the revenue requirements are allocated to particular service categories. The asset values are expressed in terms of optimised replacement cost (ORC) as required by the Rules. ORC means that the cost of equivalent modern assets required to provide the service, as if the assets were being designed and built today to provide the current customer service requirements. Table 2 below is a numerical example to show the derivation of the revenue to be allocated amongst the four different services. It assumes that the maximum allowed revenue is \$2,604,434. Note, this is an illustrative example.

Table 2: Derivation of AARR to be allocated to the four services

Derivation	Amount (\$)
Maximum allowed revenue	2,604,434
Total adjustments for:	-45,000
<ul style="list-style-type: none"> > network support pass through > cost pass through > payments under the service target performance incentive scheme > contingent projects 	
Deduct operating and maintenance expenditure (incurred in the provision of prescribed common services)	-55,000
AARR to be allocated	2,504,434

The cost share percentages shown in Table 3 are used to illustrate the allocation of revenue to be recovered from each service category. The revenue to be allocated (the AARR) is \$2,504,434. The asset values are from TransGrid's asset databases.

Table 3: Asset allocations to service categories

Category	Asset Value (\$)	Cost Share	Revenue to be recovered from each service (\$)
Exit services	6,972,222	16.2%	405,609
Entry services	1,761,111	4.1%	102,453
Shared network services	33,566,667	78.0%	1,952,741
Common services	750,000	1.7%	43,631
Total	43,050,000	100.0%	2,504,434

6. Allocation to connection point

The second step is to determine the revenue to be recovered from each connection point. In the 2016/17 financial year TransGrid has 101 connection points with its customers, by contrast Ausgrid and ActewAGL have 48 and 12.

For connection points that only provide **entry services**, the allocation is relatively straightforward. The revenue to be recovered from entry services is allocated to each connection point in proportion to the value of the entry assets employed at that connection point. As in the previous step, the allocation process is based on the ORC.

For connection points that provide **exit services**, the calculation is more complex because an allocation needs to be provided that reflects exit services, shared network services and common services. The approach to allocation of revenue to these three services is as follows:

- > For **exit services**, the approach is the same as the approach adopted for entry services. In particular, the revenue to be recovered from exit services is allocated to each connection point in proportion to the value (expressed in ORC terms) of the exit assets employed at that connection point.
- > **Common services** require an adjustment to include the operating and maintenance costs incurred in providing non-asset related common services. These non-asset related costs were removed from the AARR as described in Section 0 of this pricing methodology and in accordance with Clause 6A.22.1(2) of the Rules. This adjustment is made so that the calculation of the Annual Service Revenue Requirement (ASRR) for each transmission service (described in Section 0 above) could be allocated on an asset basis. The common service revenue must then be recovered from load connection points on a postage stamp basis, which means that the prices do not vary by location so all customers are charged the same price, although their bills will vary to reflect how much electricity they use.
- > **Shared network services** are more complex. TransGrid implements a Modified Cost Reflective Network Pricing Methodology (MCRNP) which uses utilisation adjusted optimised replacement costs to adjust the amounts recovered from locational and non-locational charges, and to provide utilisation adjusted cost reflective price signals. Shared network services are covered in further detail in section 6.2.

The following numerical examples demonstrate the approach to allocate entry, exit and common service costs to each connection point.

6.1 Worked examples for entry, exit and common services

The following examples show how the allocation of revenue is applied to entry and exit services. For entry services, this illustrative example assumes that there are two generators, Gen 1 and Gen 2. As shown in Table 3, the revenue to be allocated to entry services is \$102,453. Table 4 below shows that the annual revenue to be recovered from each generator is proportional to the asset values employed at each connection point. The asset values at each connection point and the corresponding percentage of the total is shown in Table 4 below.

Table 4: Asset Values employed at each entry point

Entry Connection Point	Asset Value (\$)	Percentage of Total	Revenue Allocation (\$)
Gen 1	1,033,333	58.7%	60,114
Gen 2	727,778	41.3%	42,338
Total	1,761,111	100.0%	102,453

Table 5 below shows a similar allocation process in relation to exit services. From Table 3, the revenue to be allocated to exit services is \$405,609. The revenue allocation to each connection point is proportional to the asset values of the exit assets at each connection point.

Table 5: Exit service revenue allocation to each exit point

Exit Connection Point	Asset Value (\$)	Percentage of Total	Exit Service Revenue Allocation (\$)
Load 1	2,083,333	29.9%	121,198
Load 2	1,405,556	20.2%	81,768
Load 3	2,633,333	37.8%	153,194
Load 4	850,000	12.2%	49,449
Total	6,972,222	100.0%	405,609

Table 3 shows that \$43,631 of revenue is to be allocated to common services. Table 2 shows that a further \$55,000, being the operating and maintenance expenditure attributable to common services, is to be allocated directly to common services, so the total revenue to be recovered is \$98,631. As shown in Table 6 below, this is attributed to each connection point according to the maximum demand at that connection point.

Table 6: Common service revenue allocation to each exit point

Exit Connection Point	Maximum Demand (MW)	Percentage of Total Maximum Demand	Common Service Revenue Allocation (\$)
Load 1	160	16.7%	16,439
Load 2	300	31.3%	30,822
Load 3	100	10.4%	10,274
Load 4	400	41.7%	41,096
Total	960	100.0%	98,631

6.2 Shared network services

6.2.1 Adjustments to the shared network revenue to be recovered

The revenue attributed to prescribed shared network services ASRR is divided between:

- > A **locational** component, which is allocated to connection points using MCRNP, ie, prices vary by location; and
- > A **non-locational** component, which is recovered on a postage stamp basis, ie, prices are the same for all customers.

This division can be on a 50-50 allocation consistent with the standard cost reflective network pricing Rule or a modified basis as per Clause 6A.23.3(a)(2) of the Rules. The locational and non-locational components of shared network services are then subject to the following adjustments

- > The shared network services revenue to be recovered on a **locational** basis is adjusted by:
 - Subtracting estimated inter-regional settlements residue auction proceeds which is not subject to a settlement residue distribution (SRD) agreement, calculated in accordance with 6A.23.3(b)(1). The estimated proceeds are converted to an equivalent asset replacement cost,

which is offset against the asset replacement cost of the relevant interconnector network assets. If the equivalent asset replacement cost is greater than the interconnector asset costs, then the interconnector asset costs are set to zero and the outstanding portion of the estimated proceeds is offset against the non-locational component. The reduced network costs are used as an input to the CRNP methodology; adding or subtracting the estimated modified load export charge (MLEC) determined in accordance with clause 6A.29A of the Rules. This adjustment is calculated in accordance with 6A.23.3(b)(2) and is discussed further in section 11; and

- If the adjusted locational component is a positive amount, then it is to be allocated to connection points of transmission customers using the MCRNP methodology in accordance with clause 6A.23.3(c). If the adjusted locational component is a negative amount, then the adjusted locational amount is deemed to be zero and the non-locational component adjusted to recover this amount in accordance with clause 6A.23.3(d) of the Rules.
- > The shared network revenue to be recovered on a **non-locational** component is adjusted in accordance with clause 6A.23.3(e) of the Rules by:
 - Subtracting settlements residue due to intra-regional loss factors;
 - For any over-recovery amount or under-recovery amount from previous years including an adjustment in accordance with 6A.23.3(f);
 - For any shortfall or over-recovery that arises from limiting the change in locational prices at a connection point (Clauses 6A.23.4(c) & (d)) as per the 2 per cent annual side constraint for changes in locational prices;
 - For any amount arising as a result of the application of prudent discounts;
 - Subtracting any portion of the settlement residue auction (SRA) proceeds that could not be offset against inter-connection assets (referred to above) when calculating the equivalent asset replacement cost; and
 - Subtracting any negative adjusted locational component (referred to above).

6.2.2 Application of the Cost Reflective Network Pricing methodology

In compliance with the Rules, a key economic requirement for a transmission pricing methodology is to provide customers with cost reflective network prices (CRNP) so that they can make efficient consumption and investment decisions. The CRNP methodology allocates a proportion based on the locational component of shared network costs to individual customer connection points. The locational price is calculated using Modified Cost Reflective Network Pricing (MCRNP) using utilisation adjusted replacement costs to adjust the amounts recovered from locational and non-locational charges, and to provide utilisation adjusted cost reflective price signals, it is described in more detail in section 6.2.3. TransGrid applies MCRNP methodology using the TPRICE cost reflective network pricing software used by most TNSPs in the National Electricity Market (NEM).

The CRNP methodology requires three sets of input data:

- > An electrical (load flow) model of the network;
- > A cost model of the network; and
- > A set of load/ generation patterns.

The choice of operating conditions is important in developing prices using the CRNP methodology. The Rules provide TransGrid with flexibility in the choice of operating conditions. The key requirements are that:

- > The allocation of dispatched generation and loads be over a range of actual operating conditions from the last full financial year; and
- > The range of operating scenarios is chosen so as to include the conditions that result in most stress on the transmission network and for which network investment may be contemplated.

The use made of the network by particular loads and generators will vary considerably depending on the load and generation conditions on the network. TransGrid's primary objective is to ensure that the application of the CRNP methodology provides stable prices that reflect, to the extent possible, the long run marginal costs of serving load. With this objective in mind, TransGrid will use a full year of hourly operating data.

Where actual operating conditions from the previous complete financial year are unavailable for a connection point, as would be the case for a new connection point, or where there are material changes in customer demand at a connection point, an estimate will be used instead. TransGrid will engage with the relevant network customer to determine the estimated demand.

Appendix A describes the CRNP methodology in more detail.

6.2.3 Modified Cost Reflective Network Pricing methodology

The essential difference between standard CRNP methodology and modified CRNP (MCRNP) methodology in calculating the network costs to be recovered for locational services is:

- > The **standard CRNP** methodology allocates shared network costs to connection points on the basis of optimised replacement costs and assumes a 50-50 split between the locational and non-locational components of network charges;
- > The **modified CRNP** methodology uses utilisation adjusted replacement costs. An average rate of return is applied to the resulting costs allocated to each connection point to determine its share of the locational component of shared network charges, ie, the arbitrary 50-50 split used with the standard CRNP methodology is removed). The rate of return is calculated so that locational charges would recover the full cost of the shared network when all network elements are assumed to be 100% utilised. The non-locational charge component recovers the balance of network costs (the costs not recovered by locational charges).

The MCRNP methodology is intended to encourage better utilisation of existing assets by discounting the costs allocated to under-utilised elements relative to those that are more heavily utilised.

The TPRICE system calculates utilisation factors based on the maximum loading of each network element over the range of operating conditions analysed ie, full financial year of half hourly operating data or estimated demand where applicable) and pricing element ratings provided as input to TPRICE.

In determining the utilisation factors required by Clause 6A.23.3(a)(2) of the Rules the MCRNP methodology ensures that asset utilisation is based on the maximum flow allowed on network elements within the normal operating constraints of the network to prevent inefficient discounting of costs in the meshed network.

As TPRICE performs its calculations based on system normal operating conditions (ie, with all elements in service) and does not carry out contingency analysis that is representative of the normal operating constraints of the network, it is necessary to apply an adjustment factor reducing element ratings for input to TPRICE to ensure that utilisation factors appropriately take into account network contingencies.

Appendix B describes the ratings adjustment for calculation of utilisation factors in more detail.

7. Set transmission pricing structures

The third and final step in setting transmission prices is to determine the pricing structure, which is the basis on which prices are calculated and applied for each service category. In a number of cases, the Rules provide no choice regarding the pricing structure. Having reviewed TransGrid's existing pricing methodology, consulted with stakeholders and considered future potential industry changes, TransGrid is satisfied that the current pricing methodology best meets the needs of customers and conforms to the Rules. Table 7 provides a summary and the remainder of this section addresses each service in turn.

Table 7: Transmission Pricing Structure

Transmission Service Charge	Description of Charge	Connection Point Specific	Single Standard Rate	Transmission Rates
Entry	Specific connection costs for each generator reflecting the assets used to support the connectio	✓		\$/day
Exit	Specific connection costs for each customer reflecting the assets used to support the connection	✓		\$/day
Locational	Charge based on customer's use of the network (both locally and more broadly) provides the price signals based on monthly maximum demand	✓		\$/kW based on customer's forecast average monthly maximum demand
Common Service	Covers cost of services that benefit all customers, specific types of assets that are not dedicated to a single connection point, eg, reactive plant		✓	\$/kW based on customer's historical annual maximum demand at each connection point
Non-locational	Recovers remaining revenue required		✓	\$/kW based on customer's historical annual maximum demand at each connection point

7.1 Entry and exit services charges

Entry and exit services charges are set on a connection specific fixed \$/day price in line with the AER guidelines, which is the same as in the current approved pricing methodology.

It is possible that entry and exit services are shared between generators or customers at a common connection point. In these cases, the costs are allocated as follows:

- > If there are multiple generators connected at a single connection point, then the entry cost would be allocated between the generators on the basis of the peak generation into the system by each generator. There are not currently any connection points in NSW or the ACT where this occurs.
- > If there are multiple customers connected at the one connection point, then the exit asset cost is allocated between the customers on the basis of the maximum demand measured for each customer in the most recent completed financial year. This arrangement currently applies at some points where two distributors share a connection point.

This pricing structure is unchanged from the current approved methodology.

7.2 Locational charges

The application of the CRNP methodology establishes a revenue amount that should be allocated to each connection point. As discussed in section 6.1 of this pricing methodology, this calculation is based on the application of MCRNP for a full financial year of half hour operating data.

The calculation requires that the dollar amount of locational costs allocated to a connection point is divided by the average of the monthly maximum demands in each month at that connection point in the previous full financial year (adjusted for forecast system load growth from the historical period to the period during which the prices will apply) and expressed as a \$/kW/month price. This pricing structure is unchanged from the current approved methodology.

For the avoidance of doubt:

1. The modified CRNP methodology is applied using historical data, to allocate locational costs to each connection point
2. A locational price is calculated for each connection point by dividing the allocated costs by the connection point maximum demand
3. The locational price for each connection point is applied to the monthly maximum demands in the billing financial year

Two points are worth noting:

- > Where there are both customer loads and generator auxiliary loads at a connection point, rates are set on the basis of the total demand at the connection point.
- > In some cases, there is a back-up supply to a particular load (eg, a town or large industrial customer) and simple application of the pricing calculation could give very different prices for the two connections. Where it is assessed that this may create incentives to the customer to switch supply points, and that this would not be consistent with efficient operation of the network, the variable rates at the two points may be set to the same level and a fixed charge used to obtain the balance of usage revenue allocated to the connection point.

This pricing structure is unchanged from the current approved methodology. The Rules require that the locational prices must not change by more than 2 per cent per annum relative to the average increase in Clauses 6A.23.4(b)(2) and 6A.23.4(b)(3), unless:

- > The load at the connection point has materially changed;
- > In connection with that change, the customer requested a renegotiation of its connection agreement with the TNSP; and
- > The AER has approved the change of more than 2 per cent per annum.

In addition, locational prices are not subject to the 2 per cent limitation to the extent that the change in prices relate to the adjusted modified load export change (MLEC) under Clause 6A.23.4(b)(3)(i) of the Rules.

These limitations on price changes are applied by TransGrid in accordance with the Rules, should the Rules in relation to this constraint change TransGrid will apply the new Rules. When this constraint is applied, non-locational prices are adjusted to compensate for the revenue mis-match.

7.3 Non-locational charges

The Rules require non-locational charges to be set on a postage stamp basis, which means that the price must be the same for all customers that are subject to the pricing methodology.

The AER's pricing methodology guidelines (Section 2.3(b)) requires the non-locational price to be calculated by dividing the non-locational revenue component by the sum of the maximum demand for all connection points. Adjustments are made to account for historical metering data not being available or significant differences between historical and current metered demand. The adjustments must be consistent with the charging arrangements, described below, to ensure that the application of the prices yields the required non-

locational component. TransGrid will charge the non-locational services as twelve equal monthly payments on the basis of historical yearly maximum demand expressed as \$/kW/month, in line with the AER's pricing methodology guidelines.

The AER's pricing methodology guidelines require that maximum demand based charges must be calculated by:

- > Multiplying the price by the maximum demand at that connection point in the corresponding billing period two years earlier (ie, historical metered maximum demand); or
- > Multiplying the price by the maximum demand at that connection point in the same billing period (current metered maximum demand) if the historical maximum demand off-take is not available; or
- > Multiplying the price by the current metered maximum demand off-take if the historical metered maximum demand is significantly different to the current metered maximum demand.

In accordance with the AER's guidelines, TransGrid will calculate non-locational charges on the basis described above. This pricing structure is unchanged from the current approved methodology.

7.4 Prescribed common service charges

The Rules require common services be priced on a postage stamp basis, which means that the price must be the same for all customers that are subject to the pricing methodology. TransGrid will calculate common service prices, and recover common service costs on a maximum demand basis, in the same manner as described in section 7.3 above, in alignment with the AER Guidelines. This pricing structure is unchanged from the current approved methodology.

7.5 Publication of transmission prices

TransGrid will publish transmission service prices on its website by 15 March each year consistent with Clause 6A.23.4(c) of the Rules.

7.6 Setting of locational prices between annual price publications

In the event that TransGrid is required to set a locational price for a new connection point after locational prices have been calculated and published, an interim price, which is not subject to the side constraints of clause 6A.23.4(b)(2) of the Rules will be calculated using the prevailing pricing models and appropriate demand forecasts. Suitable adjustments to reflect actual outcomes that differ from forecasts will be negotiated with the customer for inclusion in the relevant connection agreement. A price subject to the side constraints of clause 6A.23.4(b)(2) of the Rules will be calculated and published at the next annual price determination.

For a connection point where the load has changed significantly after locational prices have been determined and published, TransGrid will liaise with the AER and the customer for the side constraint to be relaxed, in agreement with the conditions in clause 6A.23.4(b)(3)(ii) or any new applicable Rules.

8. Billing arrangements

8.1 Billing for prescribed transmission services

TransGrid will calculate the transmission service charges payable by transmission network users for each connection point in accordance with the published transmission service prices. Where relevant, charges will reflect metering data managed by Australian Energy Market Operator (AEMO).

TransGrid will issue bills to transmission network users connected to TransGrid's network for prescribed transmission services which satisfy or exceed the minimum information requirements specified in clause 6A.27.2 of the Rules on a monthly basis or as specified in the relevant transmission connection agreement.

These requirements include:

1. Connection point identifier
2. Date of the billing period
3. For each charge the type of transmission service provided
4. Prices for each transmission service provided
5. Number of days in each month for exit and entry charges
6. Demand (MW) for locational, non-locational and common service charges
7. Amounts charged for each transmission service provided
8. Adjusted locational and non-locational charges
9. Charges for common transmission services.

Consistent with clause 6A.27.3 of the Rules a transmission network user must pay charges for prescribed transmission services properly charged to it and billed in accordance with this pricing methodology by the date specified on the bill.

8.2 Payments between Transmission Network Service Providers in the same region

As the appointed co-ordinating network service provider (CNSP) referred to in Clause 6A.29.1 of the Rules, TransGrid will pay to each TNSP in the NSW market regions the revenue which is estimated to be collected on their behalf during the following year. Such payments will be determined by TransGrid, consistent with clauses 6A.27.4 and 6A.27.5 of the Rules.

Financial transfers payable under clause 6A.27.4(b) of the Rules will be paid in equal monthly instalments or as documented in revenue collection agreements negotiated between the parties.

9. Prudential requirements

9.1 Prudential requirements for prescribed transmission services

Consistent with clause 6A.28.1 of the Rules, TransGrid may require a transmission network user to establish prudential requirements for either or both of connection services and transmission services. These prudential requirements may take the form of, but need not be limited to, capital contributions, pre-payments or financial guarantees.

The prudential requirements will be negotiated between the parties and specified in the applicable transmission connection agreement.

9.2 Capital contribution or prepayment for a specific asset

Consistent with clause 6A.28.2 of the Rules, where TransGrid is required to construct or acquire specific assets to provide prescribed connection services or prescribed shared network services to a transmission network user, TransGrid may require that user to make a capital contribution or prepayment for all or part of the cost of the new assets installed. Any contributions made are taken into account in the determination of prescribed transmission service prices applicable to that user by way of a proportionate reduction in the ORC of the asset(s) used for the allocation of prescribed charges or as negotiated between the parties.

Any prepayments made are taken into account in the determination of prescribed transmission service prices applicable to that user in a manner to be negotiated between the parties.

The treatment of such capital contributions or prepayments will be in accordance with the relevant provisions of the Rules and the revenue determination.

10. Prudent discounts

TransGrid has a very small number of customers who currently receive prudent discounts pursuant to clause 6A.26.1 of the Rules. All transmission charges paid by those customers are in accordance with the prudent discount arrangements approved by the AER.

TransGrid will address any future request for prudent discounts in accordance with the Rules requirements.

11. Inter-regional transmission charging

As the appointed Co-ordinating Network Service Provider referred to in Clause 6A.29.1 of the Rules, TransGrid is also responsible for calculating the modified load export charge (MLEC) payable to the NSW region by each interconnected region consistent with Clause 6A.29A.2 of the Rules. This charge is also known as the inter-regional transmission use of system (IR-TUOS) charge.

TransGrid will publish details of all modified load export charges to apply in the following financial year on its website by 15 February each year consistent with clause 6A.24.2(b) of the Rules.

The inter-regional transmission charging arrangement allows transmission businesses to levy a modified load export charge on transmission businesses in neighbouring regions so transmission load customers subsequently pay a share of the costs of transmission used to import electricity into their region from neighbouring regions.

11.1 Overview of the process

An overview of the process to calculate MLEC is shown in Figure 2 below.

Figure 2: MLEC calculation overview

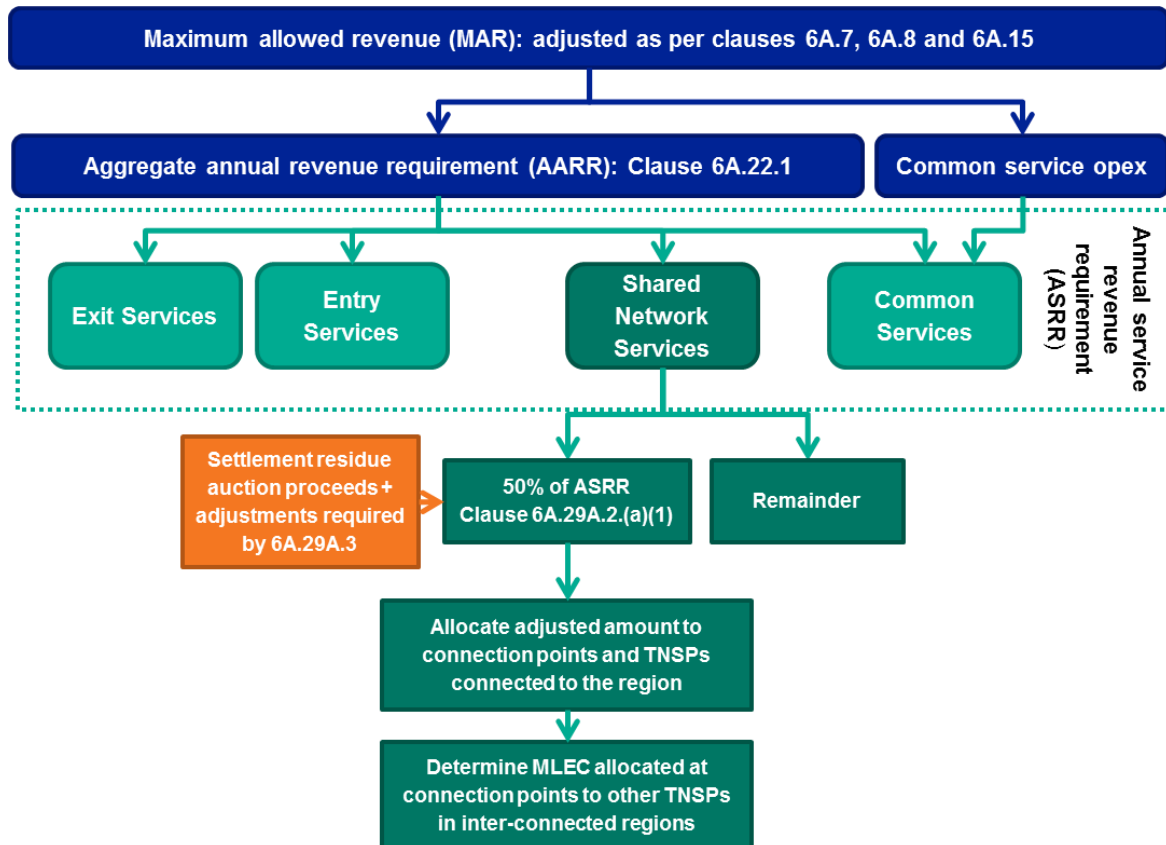

The five steps involved to calculate MLEC are:

Step 1: Aggregate annual revenue requirement (AARR)

The AARR will be calculated as described in Section 5.1 above.

The allocation of the AARR to each of the transmission service categories will be calculated as described in Section 5.2 above. This will determine the ASRR to be recovered from prescribed TUOS services.

Step 2: Annual service revenue requirement (ASRR) for shared network services

As required by Clause 6A.29A.2(a)(1) of the Rules, the modified load export charge is to be calculated from 50% of the ASRR for shared network services, ie, standard CRNP rather than modified.

Step 3: Adjustment for settlement residue auction proceeds

The amount determined in Step 2 is the shared network services revenue to be recovered on a locational basis and is adjusted in accordance with Clause 6A.29A.2(a)(2) of the Rules by:

- > Subtracting estimated inter-regional settlements residue auction proceeds;
- > Subtracting a portion of the settlements residue as referred to in clause 6A.23.3(b)(1);
- > Including any adjustments as required by 6A.29A.3.

Step 4: Standard CRNP Calculation

Clause 6A.29A.2(b)(3) requires the adjusted amount from Step 3 to be allocated to connection points of transmission customers in the NSW region and to CNSPs interconnected to the NSW region as if they were connected as transmission customers. Consistent with the requirements of Clause 6A.29A.2(b)(3), TransGrid will only use the MLEC CRNP methodology for estimating the proportionate use of the relevant transmission system assets.

As with the standard pricing methodology, TransGrid applies the CRNP methodology using the TPRICE cost reflective network pricing software used by most TNSPs in the NEM.

The network model differs slightly from the network model used for price determination for NSW market region connection points. The network model in the MLEC CRNP methodology does not require SRA proceeds to be converted into an equivalent asset as described in Section 0.

The key requirements for MLEC CRNP are:

- > The modified load export charge to be determined using standard CRNP approach
- > All transmission elements are to be included
- > All half hour periods in the previous full financial year are to be used
- > Maximum demand usage of assets must be used

For each regulatory year TransGrid will calculate the modified load export charge using the MLEC CRNP approach. The calculation will use generation and load data from the previous full financial year at the time the MLEC CRNP is being calculated.

Appendix A describes the CRNP methodology in more detail.

Step 5: Modified load export charge to be recovered

Clause 6A.29A.2(b)(4) requires the modified load export charge to be recovered from co-ordinating network service providers in interconnected regions to be the amount allocated to connection points to neighbouring regions as determined in Step 4. This currently applies to Queensland and Victoria.

11.2 Timetable for the provision of data

As required by 6A.29A.4(e), each TNSP located in the NSW market region is required to provide TransGrid with all information reasonably required for the calculation of the MLEC estimate.

To facilitate this information transfer, Section 2.6 of the AER guidelines require the CNSP to specify a timetable for the provision of all necessary data for the calculation of the inter-regional and intra-regional transmission charges.

The following timetable in Figure 3, for the provision of data, will facilitate the calculation of all modified load export charges to apply in the NSW region by 15 February each year.

Figure 3: MLEC data provision timetable

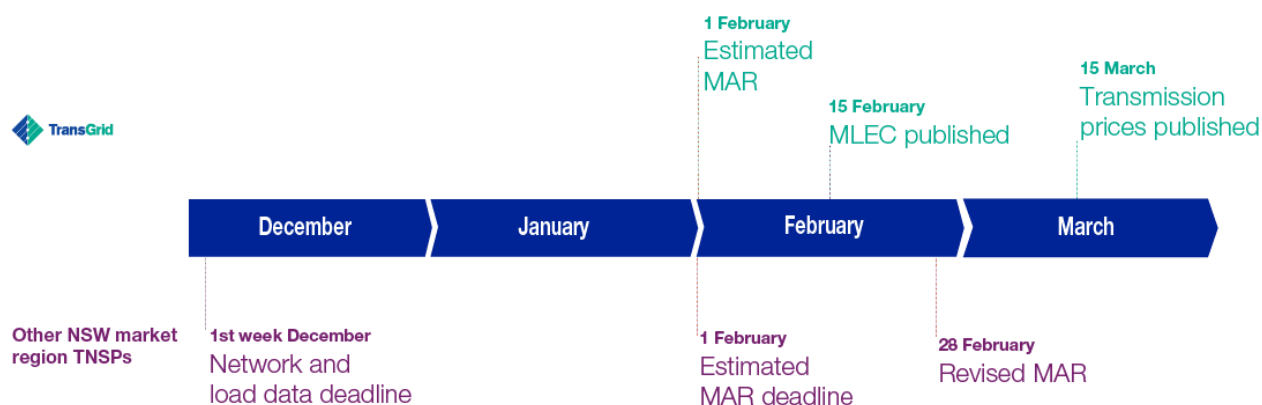

11.3 Billing the modified load export charge

TransGrid will issue a monthly bill to the CNSP in each interconnected region for the MLEC amount payable to TransGrid in accordance with Clause 6A.29A.4(a) of the Rules. The monthly bills will include any adjustments made to it in accordance with the Rules (Clause 6A.29A.3 of the Rules).

In accordance with Clause 6A.29A.4(b) of the Rules, the monthly bill will include:

- > The total annual estimate of MLEC payable by the CNSP;
- > Details of the MLEC CRNP allocation and the adjustments as specified in Clauses 6A.29A.3 and 6A.23.3(f); and
- > The monthly instalment amount.

11.4 Billing arrangements between multiple TNSPs in a region

11.4.1 Allocation of amounts to each TNSP in the same region

In accordance with clause 6A.29A.5(a) of the NER, where there is more than one TNSP in a region, the Coordinating Network Service Provider must allocate any amounts receivable or payable to it for MLEC to each Transmission Network Service Provider.

As the appointed CNSP referred to in Clause 6A.29.1 of the Rules, TransGrid will allocate any amounts receivable or payable for MLEC to each relevant TNSP in the NSW region for the following year.

This allocation will be based on the MLEC CRNP methodology for estimating the proportionate use of the relevant transmission system assets. The allocation of amounts will be calculated according to intra-regional, rather than inter-regional, network utilisation. For the avoidance of doubt, these amounts will be incorporated in the connection point prices calculated by TransGrid for each TNSP in the NSW market region, which is currently Ausgrid, Directlink and ActewAGL.

11.4.2 Billing each TNSP in the same region

TransGrid will issue a bill to each TNSP in the NSW region for the net amount of MLEC as required in clause 6A.29A.5(b) of the Rules to be paid in equal monthly instalments or as documented in revenue collection

agreements negotiated between the parties. Such payments will be calculated by TransGrid. TransGrid will also provide reasonable details on the calculation of these amounts.

11.5 Worked example – modified load export charge

The worked example uses the same amounts referred to in the examples of the proposed pricing methodology.

Step 1: Aggregate annual revenue requirement (AARR)

In accordance with Clause 6A.22.1, the maximum allowed revenue is adjusted:

- > In accordance with clause 6A.3.2, and
- > By subtracting the operating and maintenance costs expected to be incurred in the provision of prescribed common transmission services; and
- > By any allocation as agreed between Transmission Network Service Providers in accordance with clause 6A.29.3.

This example is based on the previous one in Section 5.1 and assumes that the maximum allowed revenue is \$2,604,434.

Step 2: Annual service revenue requirement (ASRR) for shared network services

As per the example in section 5.2, the ASRR for each category of service must be calculated. The cost share percentages are used to allocate the revenue to be recovered from each service category. In accordance with the adjustments set out in Table 3 section 5.3 the revenue to be allocated (the AARR) is \$2,504,434.

Clause 6A.29A.2(a)(1) then requires 50% of the ASRR for shared network services to be calculated, which in this illustrative example is \$976,371.

Step 3: Adjustment for settlement residue auction proceeds

For this example the SRA proceeds and other adjustments are assumed to be zero.

Step 4: Standard CRNP Calculation

An electrical model of the NSW transmission network is set up including all transmission elements. The TPRICE software is used to calculate the allocation of costs based on a proportionate use of transmission system assets.

For the NSW network, TPRICE is used to determine the cost allocation for each TNSP separately within the market region. The total allocation to each connection point to another region is then determined as shown in Table 8.

Table 8: Standard CRNP allocation and Interconnector cost share

Connection Point	CRNP ORC Allocation (\$k)	Cost Share
Dederang	1,000	3%
Red Cliffs	300	1%
Wodonga	500	1%
Queensland via Directlink	600	2%
QNI	400	1%
Total for Interconnector connection points	2,800	8%
Total for all connection points	33,566,667	

Step 5: Modified load export charge to be recovered

The revenue to be recovered is pro-rated using the adjusted AARR from Step 2 as shown in Table 9.

Table 9: Modified load export charge

Connection Point	Cost Share	Revenue to be recovered from each connection point (\$)
Dederang	3%	29,087
Red Cliffs	1%	8,726
Wodonga	1%	14,543
Modified load export charge for the Victorian region		52,356
Queensland via Directlink	2%	17,452
QNI	1%	11,635
Modified load export charge for the Queensland region		29,089

11.6 Worked example – allocation and billing to other TNSPs in NSW region

The allocation of net MLEC to each TNSP in the NSW region is based on the CRNP cost allocations to connection points. This allocation broken up on a TNSP basis is shown in Table 10.

This allocation of net MLEC is performed in accordance with the rule requirement 6A.29A.5(b) that requires a CNSP to issue a bill to each TNSP within the region of the net MLEC payable or receivable. In actual fact, the net MLEC amount is already included in the calculated prices for each TNSP, so there is no net MLEC amount to be transferred to or from the CNSP. This calculation is solely for information purposes and to satisfy rule 6A.29A.5.

Table 10: CRNP allocation and percentage of total, on a TNSP basis

TNSPs in NSW	CRNP ORC Allocation (\$k)		CRNP ORC Allocation (\$k)		Total CRNP ORC Allocation (\$k)	
	Victoria		Queensland		to each TNSP	
TransGrid	1,783	(99.1%)	900	(90.0%)	2,683	(95.8%)
Ausgrid	8	(0.4%)	4	(0.4%)	12	(0.4%)
Directlink	9	(0.5%)	96	(9.6%)	105	(3.8%)
ActewAGL	0	(0.0%)	0	(0.0%)	0	(0.0%)
Total for interconnector connection points	1,800	(100%)	1,000	(100%)	2,800	(100%)

The net MLEC amount allocated to each TNSP is then obtained by pro-rating the total MLEC amounts by the CRNP allocation as shown in Table 11.

Table 11: Calculation of MLEC attributed to each TNSP in the NSW region

TNSPs in NSW	Net MLEC for the Victorian region (\$k)	Net MLEC for the Queensland region (\$k)	Net MLEC for each TNSP (\$k)
TransGrid	51,884.80	26,180.10	78,065
Ausgrid	209.42	116.36	326
Directlink	261.78	2,792.54	3,054
ActewAGL	0.00	0.00	0
Total net MLEC for each interconnecting region	52,356	29,089	81,445

12. Monitoring and compliance

As a regulated business TransGrid is required to maintain extensive compliance monitoring and reporting systems to ensure compliance with its obligations under the National Electricity Law, the Rules and guidelines.

In order to monitor and maintain records of its compliance with its approved pricing methodology, the pricing principles for prescribed transmission services, and part J of the Rules, TransGrid:

- > Incorporates the specific obligations arising from part J of the Rules into its compliance management system;
- > Maintains electronic records of the annual calculation of prescribed transmission service prices and supporting information; and
- > Periodically subjects its transmission pricing models and processes to functional audit by suitably qualified persons.

13. Description of pricing methodology differences

In line with feedback received during the 2016 customer engagement program, TransGrid considers that the proposed pricing methodology will continue to promote the achievement of the National Electricity Objective and deliver customer's pricing objectives. There are no differences between the pricing methodology set out in this paper and TransGrid's current pricing methodology.

For clarity, TransGrid will continue to apply the following:

- > Prices will be set according to maximum demand.
- > TransGrid will continue to apply the modified CRNP methodology for the calculation of transmission prices.

Appendix A – Cost Reflective Network Pricing methodology

The cost reflective network pricing (CRNP) methodology involves the following steps:

Annual Costs: Determine the annual costs of the individual transmission network assets in the optimised transmission network

Utilisation Adjustment: For modified CRNP, adjust each asset's cost according to its utilisation

Proportion of Network Elements: Determine the proportion of each individual network element utilised in providing a transmission service to each point in the network for specified operating conditions

Maximum flow: Determine the maximum flow imposed on each transmission element by load at each connection point over a set of operating conditions

Allocate costs: Allocate the costs attributed to the individual transmission elements to loads based on the proportionate use of the elements

Total Costs: Determine the total cost (lump sum) allocated to each point by adding the share of the costs of each individual network element attributed to each point in the network

Utilisation Adjustment

The maximum utilisation is calculated in agreement with TransGrid's planning standards and actual utilisation may differ depending on the network outages that occurred historically.

Proportion of network elements

A major assumption in the use of the CRNP methodology is the definition of the generation source and the point where load is taken. The approach is to use the "electrical distance" to pair generation to load, in which a greater proportion of load at a particular location is supplied by generators that are electrically closer than those that are electrically remote. In electrical engineering terminology the "electrical distance" is the impedance between the two locations, and this can readily be determined through a standard engineering calculation called the "fault level calculation".

Once the assumption has been made as to the generators that are supplying each load for a particular load and generation condition (time of day) it is possible to trace the flow through the network that results from supplying each load (or generator). The use made of any element by a particular load is then simply the ratio of the flow on the element resulting from the supply to this load to the total use of the element made by all loads and generators in the system.

Maximum flow

The choice of operating conditions is important in developing prices using the CRNP or MCRNP methodology. Schedule 6A.3.2(3) requires that the allocation of dispatched generation to loads be over a range of actual operating conditions from the previous financial year and that the range of operating scenarios

is chosen so as to include the conditions that result in most stress on the transmission network and for which network investment may be contemplated.

The use made of the network by particular loads and generators will vary considerably depending on the load and generation conditions on the network. For this reason operating scenarios for each hour in a full financial year are examined with different load and generation patterns to comply with the Rules and ensure efficient price signalling.

In selecting those operating scenarios it is important to recognise that the operating conditions that impose most stress on particular elements may occur at times other than for system maximum demand.

Appendix B – Calculating utilisation factors

When assigning a proportion of shared network costs to individual customer connection points the MCRNP methodology reduces the ORC of each shared network pricing element (line or transformer) by a utilisation factor that reflects the maximum loading of the branch with respect to its rating.

In determining the appropriate rating for entry into TPRICE (used to perform the MCRNP calculations) it is important to understand that TPRICE only considers system normal operating conditions whereas the shared network must be able to withstand a single contingency outage without overloading any network element consistent with the requirements of the Rules and the Transmission Network Design and Reliability Standard published by the NSW government.

This means that utilisation factors calculated with respect to equipment ratings (thermal line ratings and transformer nameplate ratings) under system normal conditions would result in artificially low utilisation factors.

This problem can be overcome by reducing the equipment ratings to reflect the maximum flow on a network branch under system normal conditions that would not result in its absolute rating being exceeded in the event of the worst contingency.

The reduced ratings are calculated by examining flows in network elements over a range of maximum demand system operating conditions first for system normal conditions, and then with each meshed network element out of service one at a time. For each network element, the ratio of maximum system normal flow to maximum contingency flow is used to scale down the absolute equipment rating to obtain the reduced rating for input to TPRICE.

This process can best be illustrated by an example. A line has an absolute (thermal) rating of 200 MV.A. network analysis over a range of maximum demand operating conditions shows that this line has a maximum system normal flow of 120 MV.A and a maximum single contingency flow of 160 MV.A. The reduced rating of this line (as input to TPRICE) is $(120/160) * 200$ giving 150 MV.A.

When TPRICE is run, analysis will consider flows on this line over a much wider range of operating conditions (than used in the contingency analysis) some of which may even exceed 120 MV.A. If the highest usage of this line over the operating conditions assessed by TPRICE is 123 MV.A, then the utilisation factor used by TPRICE with modified CRNP will be 0.82 (123/150).

Appendix C – Priority ordering methodology

Rules Requirement

Clause 6A.23.2(d) of the Rules requires that:

Where, as a result of the application of the attributable cost share, a portion of the AARR would be attributable to more than one category of prescribed transmission services, that attributable cost share is to be adjusted and applied such that any costs of a transmission system asset that would otherwise be attributed to the provision of more than one category of prescribed transmission services, is allocated as follows:

- > To the provision of prescribed shared network services, but only to the extent of the stand-alone amount for that category of prescribed transmission services;
- > If any portion of the costs of a transmission system asset is not allocated to prescribed shared network services, under subparagraph (1), that portion is to be allocated to prescribed common transmission services, but only to the extent of the stand-alone amount for that category of prescribed transmission services;
- > If any portion of the costs of a transmission system asset is not attributed to prescribed transmission services under subparagraphs (1) and (2), that portion is to be attributed to prescribed entry services and prescribed exit services.

Stand-alone amount is defined as:

For a category of prescribed transmission services, the costs of a transmission system asset that would have been incurred had that transmission system asset been developed exclusively to provide that category of prescribed transmission services.

In its rule determination the AEMC provided the following guidance on the application of the priority ordering approach for the allocation of costs which can be attributed to more than one type of service:¹

“The Commission has maintained a priority ordering approach for the allocation of expenses or costs which can be attributed to more than one type of service. The cascading principle adopted by the Commission is based on the premise that users are seen to be the ‘cause’ of transmission investment. Therefore, costs should be first allocated to prescribed transmission use of system services on a stand-alone basis and then to prescribed common transmission services. Where a service/cost cannot justifiably be attributed to TUOS or common services it should be allocated to entry and exit services.”

In developing this methodology TransGrid has had regard for the following example in the rule determination:²

Consider a substation costing \$30 million that was developed:

- > Partly in order to provide prescribed TUOS services;
- > Partly in order to provide prescribed common transmission services; and
- > Partly in order to provide prescribed exit services.

Then assume that had the substation been developed solely to provide prescribed TUOS services, it could have been much smaller and would have cost only \$10 million. Had the substation been developed solely in order to provide prescribed common transmission services, it would have cost \$5 million. Finally, had the substation been developed solely in order to provide prescribed exit services, it would have cost \$20 million.

¹ AEMC, *Rule Determination for National Electricity Amendment (Pricing of Prescribed Transmission Services) Rule 2006*, p5.

² Ibid p37.

The application of the principle would then lead to the \$30 million cost of the substation being attributed to Prescribed Transmission Service categories as follows:

- > \$10m to the prescribed TUOS services ASRR;
- > \$5m to the prescribed common services ASRR; and
- > The remaining \$15 million to the prescribed exit service ASRR.

Objective and General Approach

The proposed allocation methodology relies on the assumption that substation infrastructure and establishment costs are proportionate to the number of high voltage circuit breakers in the substation.

Based on this assumption the appropriate allocator for substation infrastructure and establishment costs for a stand-alone arrangement is the ratio of the number of high voltage circuit breakers in the stand-alone arrangement to the number of high voltage circuit breakers in the whole substation. Low voltage circuit breakers are not considered in the standalone arrangements

Proposed Methodology

Step 1: Element Identification

Identify the element being the lines, transformers, major reactive devices and exits/entries in the substation which provide shared network services, common transmission services and exit or entry services, in the substation. Further definition is provided below. As a general rule, Distribution Network Service Providers (DNSPs) are classified as a prescribed exit service while Generators are classified as a prescribed entry service. As with the rest of this pricing methodology, negotiated services are not part of the regulated asset base and fall outside the priority ordering process detailed in clause 6A.23.2(d) of the Rules.

Step 2: Allocation of Circuit Breakers to Elements

For each high voltage circuit breaker in the substation identify the elements directly connected to it. Any circuit breaker that does not directly connect to an element is excluded from allocation and all costs associated with it are added to the substation infrastructure and establishment cost.

Count the total number of circuit breakers directly connected to elements.

Step 3: Stand-alone arrangements

Step 3.1: Stand-alone arrangements for shared network services

With reference to the number of lines providing shared network services determine the number of circuit breakers required to provide services of an equivalent standard on a stand-alone basis. Whilst an argument can be made that a substation would typically not exist to provide shared network services alone it is believed that this is inconsistent with the intent of the rule. Accordingly standalone arrangements for prescribed shared network services are taken to require a level of switching consistent with the prevailing bus arrangements. The stand-alone configuration is the simplest substation configuration (in the absence of development) had it been developed to provide a shared network service. This may be done by referencing typical stand-alone configurations.

Step 3.2: Stand-alone arrangements for common transmission services

With reference to the number of lines providing shared network services and the devices providing common service determine the number of circuit breakers required to provide common transmission services of an equivalent standard on a stand-alone basis. The stand-alone configuration is the simplest substation configuration (in the absence of development) had it been developed to provide a common service. This may be done by referencing typical stand-alone configurations.

Step 4: Allocation of substation infrastructure and establishment costs

Step 4.1: Allocation of shared network services

Allocate a portion of substation infrastructure and establishment costs to shared network services according to the ratio of the high voltage circuit breakers identified in step 3.1 to the total number of high voltage circuit breakers connected to elements in the substation identified in step 2.

Step 4.2: Calculate the unallocated substation infrastructure costs after shared network services allocation

Calculate the unallocated substation infrastructure cost by subtracting the amount calculated in step 4.1 from the total substation infrastructure amount.

Step 4.3 Allocation of common service

Allocate a portion of the substation infrastructure and establishment costs to common service based on to the ratio of the high voltage circuit breakers providing common transmission services identified in step 3.2 to the total number of high voltage circuit breakers connected to branches in the substation. If the common service portion of substation infrastructure is greater than the unallocated costs, then the unallocated portion only is attributed to prescribed common service. In this instance, nothing will be attributed to entry and exit services.

Step 4.4: Calculate the unallocated substation infrastructure costs after common service allocation

Calculate the unallocated substation infrastructure cost by subtracting the amount calculated in step 4.3 from the amount calculated in step 4.2.

Step 4.5: Allocation of entry and exit service

Allocate the remaining substation infrastructure and establishment costs (calculated in step 4.4) to each branch providing prescribed exit or entry services based on the ratio of the high voltage circuit breakers providing the entry or exit service to the element to the total number of high voltage circuit breakers providing entry or exit services or in accordance with the cost allocation process.

Costs are only allocated in step 4 until fully allocated.

- > Consistent with clause 6A.23.2(d)(3) of the Rules it is possible that no costs will be attributed to entry and exit services.
- > New and existing negotiated service assets are excluded from the analysis as any incremental establishment costs associated with them are taken to be included in the negotiated services charges on a causation basis.
- > The assessment of standalone arrangements only needs to be conducted once per substation except where changes to the configuration of the substation occur.

Definitions and examples are set out on the following pages.

Elements diagrams

As illustrated by the diagrams below an “Element” is a collection of assets, eg, lines, circuit breakers, capacitors, buses and transformers) that provide a transmission service.

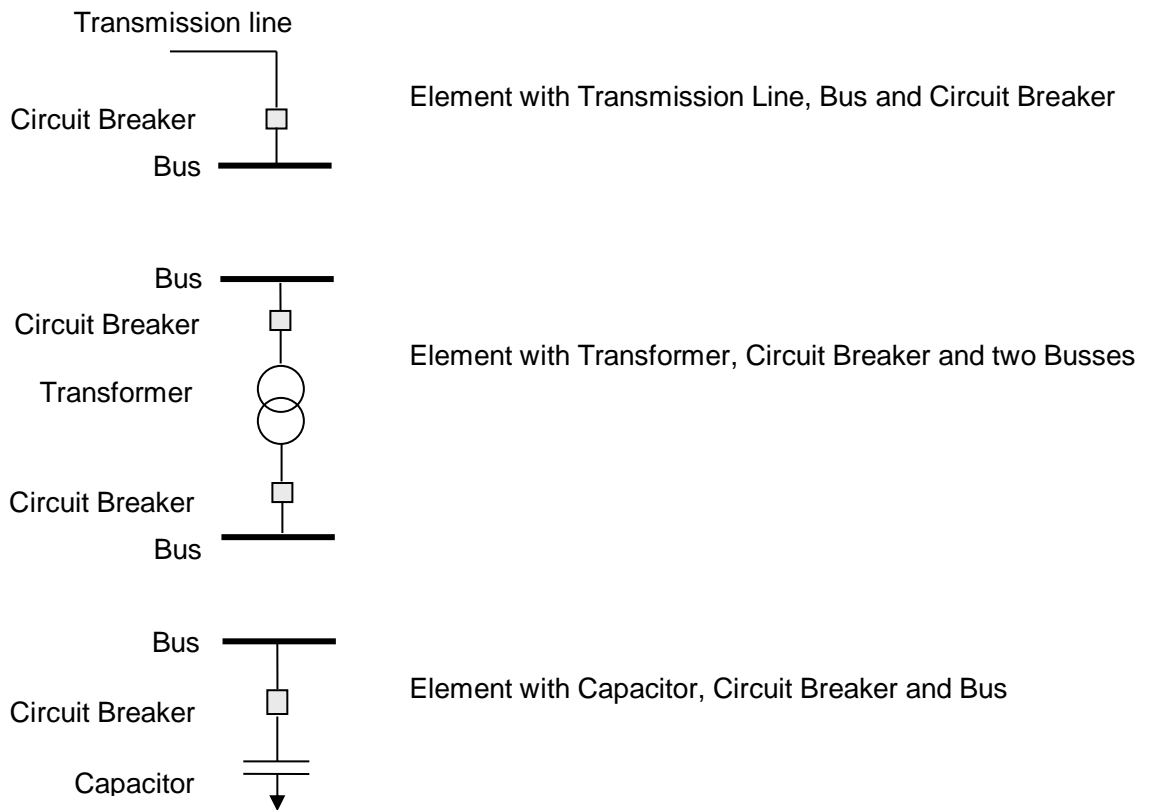

Elements Examples

Example A

The substation configuration is shown in the diagram below.

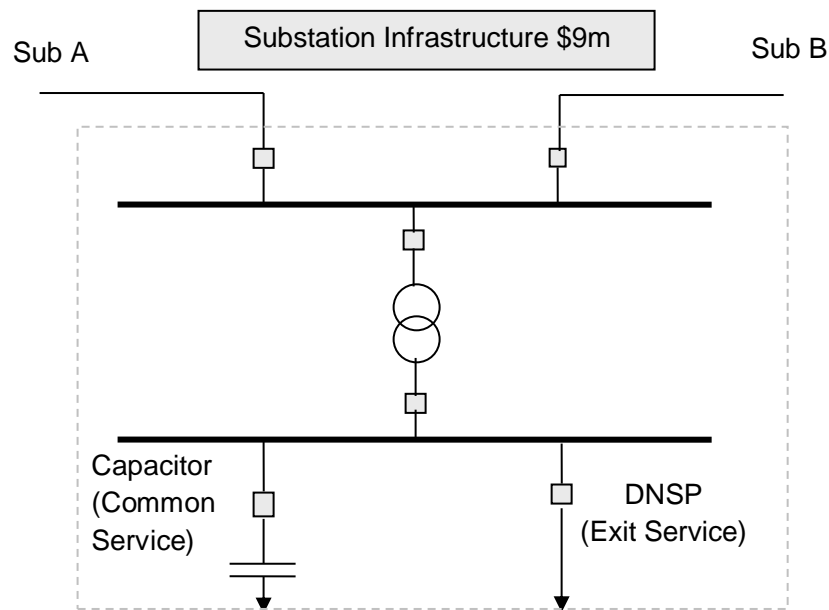

Step 1: The elements are Sub A, Sub B, DNSP, Tie Transformer and PCS.

Step 2: The total number of circuit breakers directly connected to elements is 6.

Step 3.1: The stand-alone arrangement for the provision of shared network services to an equivalent standard is shown below and consists of 2 circuit breakers.

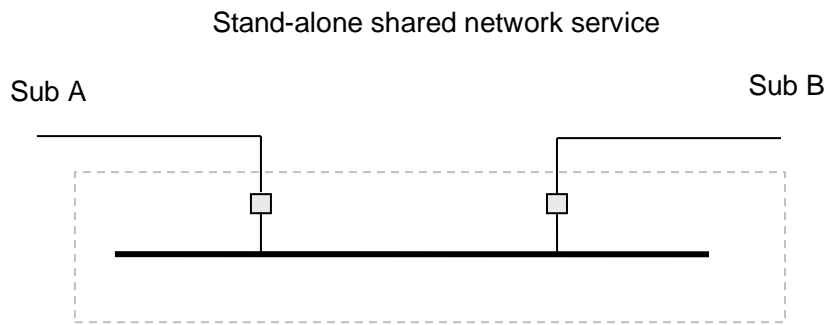

Step 3.2: The stand-alone arrangement for the provision of common transmission services to an equivalent standard is shown below and consists of 3 circuit breakers.

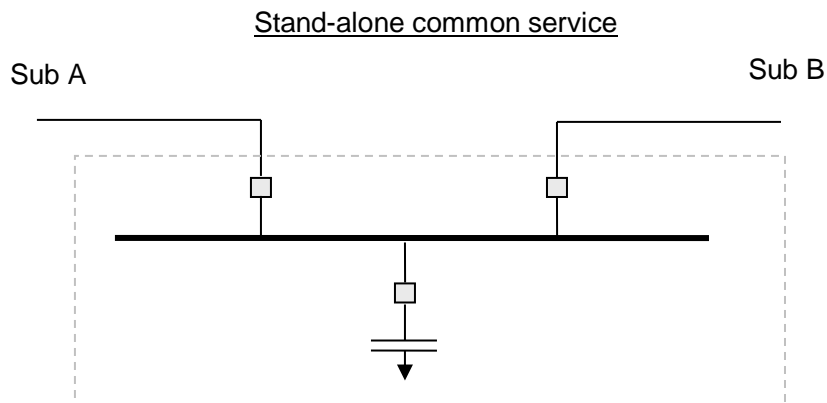

Step 4:

Assume total infrastructure cost is \$9m.

Costs are allocated to shared network service in the ratio of the circuit breakers in the stand-alone arrangement to the total circuit breakers.

Infrastructure cost allocated to shared network service = $(2/6) \times \$9m = \$3m$

Unallocated = $\$9m - \$3m = \$6m$

Costs are allocated to common service in the ratio of the circuit breakers in the stand-alone arrangement to the total circuit breakers.

Infrastructure cost allocated to common service = $(3/6) \times \$9m = \$4.5m$

Unallocated = $\$6m - \$4.5m = \$1.5m$

Remainder of unallocated (calculated above) to be allocated to entry and exit services.

Infrastructure cost allocated to exit service = $\$1.5m$

Item	Number	Allocation	Unallocated
Substation infrastructure costs		9,000,000	9,000,000
Total breakers	6		
Shared network stand-alone breakers	2		
Share to shared network	0.333	3,000,000	6,000,000
Common service stand-alone breakers	3		
Share to common service	0.500	4,500,000	1,500,000
Share to entry and exit services		1,500,000	

Example B

The substation configuration is shown in the diagram below.

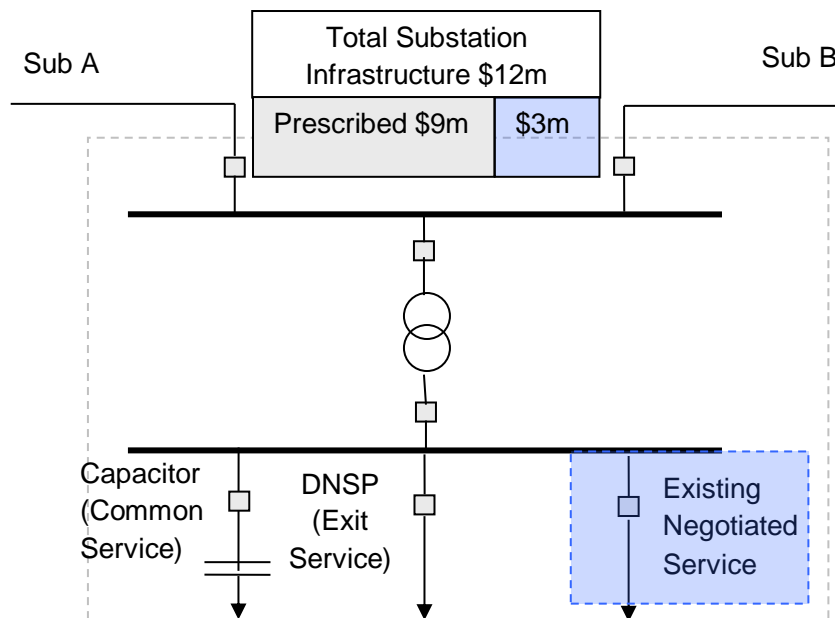

Step 1: The elements are Sub A, Sub B, DNSP, Tie Transformer, PCS and an existing negotiated service.

Step 2: The total number of circuit breakers directly connected to elements is 6 (no prescribed costs are allocated to the existing negotiated service).

Step 3.1: The stand-alone arrangement for the provision of shared network services to an equivalent standard is shown below and consists of 2 circuit breakers.

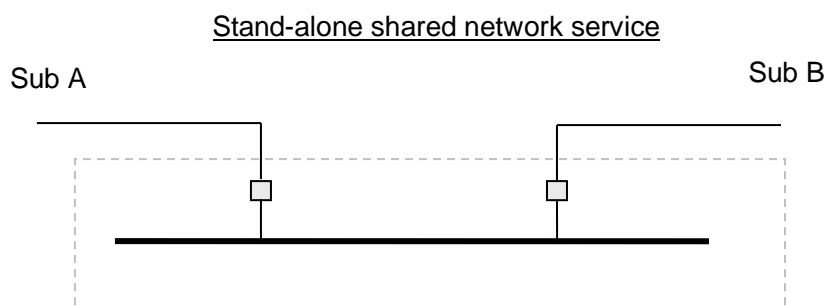

Step 3.2: The stand-alone arrangement for the provision of common transmission services to an equivalent standard is shown below and consists of 3 circuit breakers.

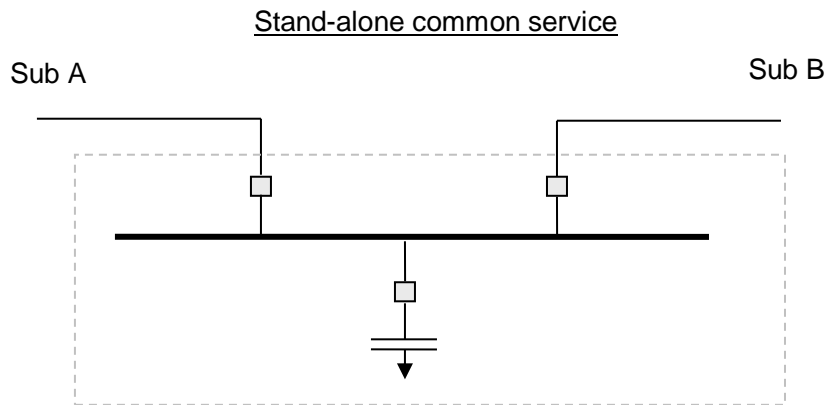

Step 4:

Assume total infrastructure cost is \$12m, however \$3m is for the existing negotiated service, which does not form part of the regulated asset base and is not governed by 6A.23.2(d).

Costs are allocated to shared network service in the ratio of the circuit breakers in the stand-alone arrangement to the total circuit breakers.

Infrastructure cost allocated to shared network service = $(2/6) \times \$9m = \$3m$

Unallocated = $\$9m - \$3m = \$6m$

Costs are allocated to common service in the ratio of the circuit breakers in the stand-alone arrangement to the total circuit breakers.

Infrastructure cost allocated to common service = $(3/6) \times \$9m = \$4.5m$

Unallocated = $\$6m - \$4.5m = \$1.5m$

Remainder of unallocated (calculated above) to be allocated to entry and prescribed exit services.

Infrastructure cost allocated to exit = $\$1.5m$

Item	Number	Allocation	Unallocated
Substation infrastructure costs		9,000,000	9,000,000
Total breakers	6		
Shared network stand-alone breakers	2		
Share to shared network services	0.333	3,000,000	6,000,000
Common service stand-alone breakers	3		
Share to common service	0.500	4,500,000	1,500,000
Share to entry and exit services		1,500,000	

Example C

The substation configuration is shown in the diagram below.

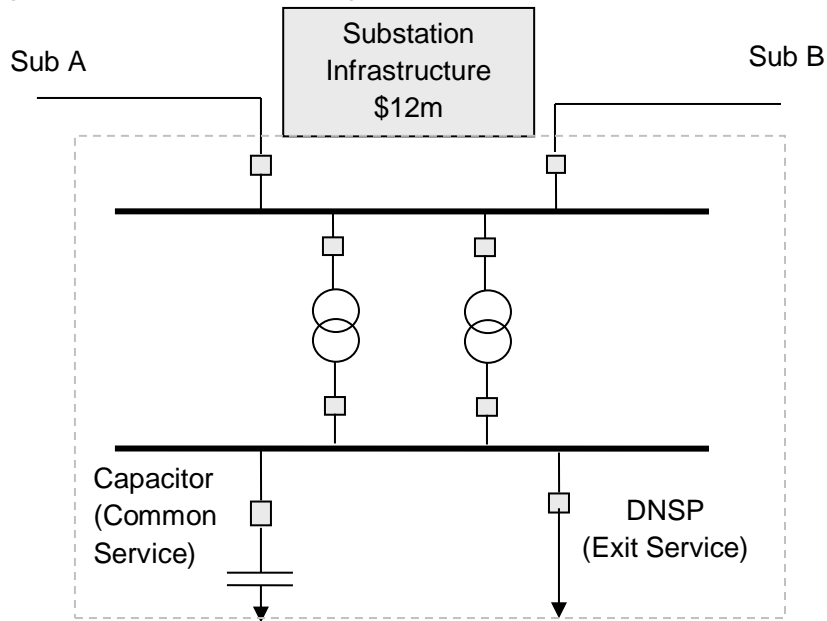

Step 1: The elements are Sub A, Sub B, DNSP, Tie Transformer 1, Tie Transformer 2 and PCS.

Step 2: The total number of circuit breakers directly connected to elements is 8.

Step 3.1: The stand-alone arrangement for the provision of shared network services to an equivalent standard is shown below and consists of 2 circuit breakers.

Stand-alone shared network services



Step 3.2: The stand-alone arrangement for the provision of common transmission services to an equivalent standard is shown below and consists of 3 circuit breakers.

Stand-alone common service

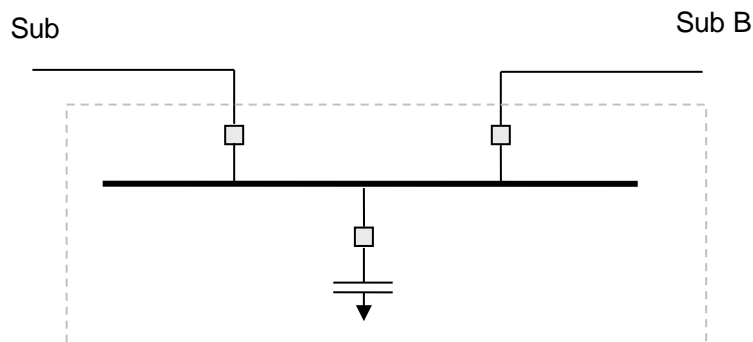

Step 4:

Assume total infrastructure cost is \$12m.

Costs are allocated to shared network service in the ratio of the circuit breakers in the stand-alone arrangement to the total circuit breakers.

Infrastructure cost allocated to shared network service = $(2/8) \times \$12m = \$3m$

Unallocated = $\$12m - \$3m = \$9m$

Costs are allocated to common service in the ratio of the circuit breakers in the stand-alone arrangement to the total circuit breakers.

Infrastructure cost allocated to common service = $(3/8) \times \$12m = \$4.5m$

Unallocated = $\$9m - \$4.5m = \$4.5m$

Remainder of unallocated (calculated above) to be allocated to entry and prescribed exit services.

Infrastructure cost allocated to exit = $\$4.5m$

Item	Number	Allocation	Unallocated
Substation infrastructure costs		12,000,000	12,000,000
Total breakers	8		
Shared network service stand-alone breakers	2		
Share to shared network service	0.250	3,000,000	9,000,000
Common service stand-alone breakers	3		
Share to common service	0.375	4,500,000	4,500,000
Exit service		4,500,000	

Example D

The substation configuration is shown in the diagram below.

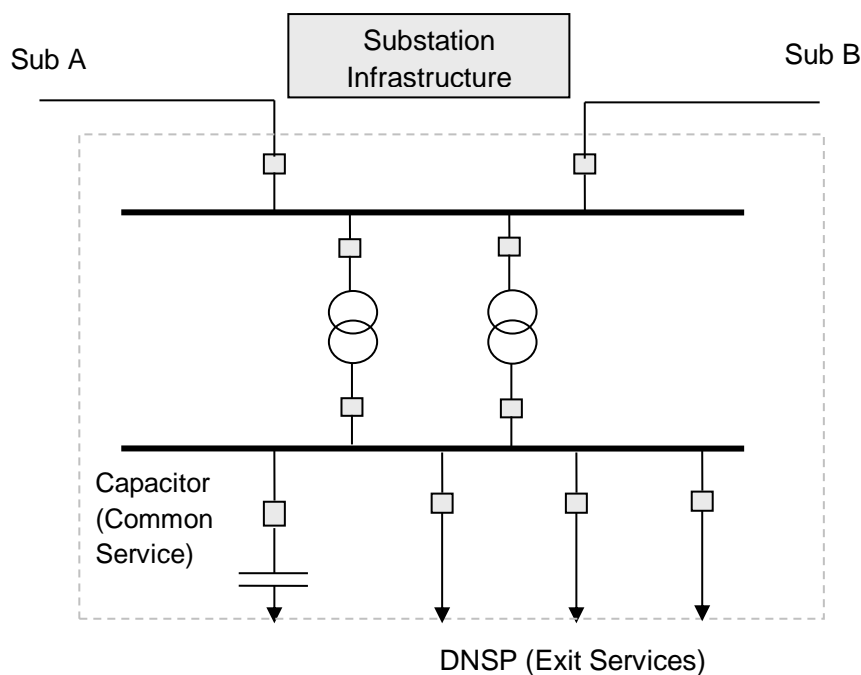

Step 1: The elements are Sub A, Sub B, DNSP1, DNSP2, DNSP3, Tie Transformer 1, Tie Transformer 2 and PCS.

Step 2: The total number of circuit breakers directly connected to elements is 10.

Step 3.1: The stand-alone arrangement for the provision of shared network services to an equivalent standard is shown below and consists of 2 circuit breakers.

Stand-alone shared network service



Step 3.2: The stand-alone arrangement for the provision of common transmission services to an equivalent standard is shown below and consists of 3 circuit breakers.

Stand-alone common service

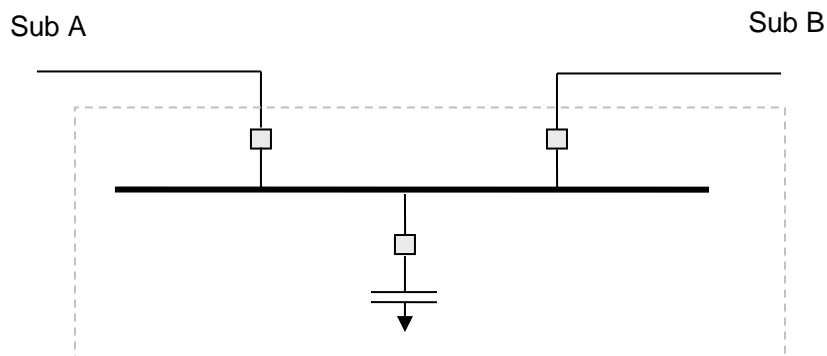

Step 4:

Assume total infrastructure cost is \$15m.

Costs are allocated to shared network service in the ratio of the circuit breakers in the stand-alone arrangement to the total circuit breakers.

Infrastructure cost allocated to shared network services = $(2/10) \times \$15m = \$3m$

Unallocated = $\$15m - \$3m = \$12m$

Costs are allocated to common service in the ratio of the circuit breakers in the stand-alone arrangement to the total circuit breakers.

Infrastructure cost allocated to common service = $(3/10) \times \$15m = \$4.5m$

Unallocated = $\$12m - \$4.5m = \$7.5m$

Remainder of unallocated (calculated above) to be allocated to entry and prescribed exit services.

Infrastructure cost allocated to exit services = \$7.5m

Item	Number	Allocation	Unallocated
Substation infrastructure costs		15,000,000	15,000,000
Total breakers	10		
Shared network service stand-alone breakers	2		
Share to shared network service	0.200	3,000,000	12,000,000
Common service stand-alone breakers	3		
Share to common service	0.300	4,500,000	7,500,000
Exit service		7,500,000	