



**ES7**  
**Network Price Guide**  
April 2017



## Scope

This publication explains the terms and conditions of Ausgrid's Network Use of System (NUOS) tariffs. It does not address charges for alternative control services.

## Document and Amendment History

Issue No.	Date	Approved By	Summary of changes
1.0	August 2016	A/Manager-Regulation	Document title changed to "Network Price Guide". Scope of document limited to tariff related information. Updated to reflect changes to tariff arrangements.
1.1	October 2016	Manager – Network Pricing	Minor change to the glossary section.
1.2	October 2016	Manager – Network Pricing	Additional explanatory text added to Chapter 2 of document. Minor change to the glossary section.
1.3	November 2016	Manager – Network Pricing Endorsed by Billing Manager	Additional explanatory text added to Chapter 3 of document. Minor change to the glossary section.
1.4	December 2016	Manager – Network Pricing	Additional Appendix E added to document.
1.5	December 2016	Manager – Network Pricing	Additional Appendix F added to document.
1.6	February 2017	Manager – Network Pricing	Additional explanatory text added to Chapter 2 of document.
1.7	March 2017	Manager – Network Pricing	Additional Appendix G added to document.
1.8	April 2017	Manager – Network Pricing	Additional explanatory text added to Chapter 3 of document.

## Document Approval

Role	Date	Title	Name
Approver	August 2016	A/Manager - Regulation	Son Truong Vu
Endorser	August 2016	Manager – Network Pricing	Robert Telford
Drafting	August 2016	Network Forecasting Manager	Patrick Gannon
Author	March 2016	Senior Pricing Analyst	Brian Newman
Author	March 2016	Metering Asset Strategy & Technology Manager	Boris Kobal
Reviewer	March 2016	Load Control Manager	William Chesterton
Reviewer	March 2016	Program Development Manager	Robert Simpson
Reviewer	March 2016	Billing Manager	Ross McAlpine

## Disclaimer

This document has been prepared by Ausgrid in good faith to provide an explanation of the application of our NUOS tariffs.

The information set out in this document may be subject to revision or replacement due to a range of factors including:

- The evolving electricity market and commercial experience within that market;
- Regulatory decisions by the Australian Energy Regulator;
- Changes to the National Electricity Rules; and

- Government and industry regulation.

Application of this document to particular users will be dependent upon the circumstances of that user and may vary between users.

This document should be read in conjunction with Ausgrid's Tariff Structure Statement, Ausgrid's Undertaking under section 59A of the National Electricity Law and Ausgrid's 2015/16 Annual Pricing Proposal document as we were not required to submit a Pricing Proposal for FY2016/17. These documents are available from [www.aer.gov.au](http://www.aer.gov.au) or [www.ausgrid.com.au](http://www.ausgrid.com.au).

In the event of inconsistency, the following order of precedence applies:

1. Ausgrid's Undertaking under section 59A of the National Electricity Law;
2. the relevant annual Pricing Proposal; and
3. this Network Price Guide document

Accordingly, to the extent permitted by law, Ausgrid excludes liability for all losses, damages, claims and expenses suffered or incurred by any person arising out of or in connection with any use of this document.

### **Warning**

It is the responsibility of the user of this document to ensure that only the current version is being used. Ausgrid may amend this document at any time.

ISSN 1032-7215

Published and printed by Ausgrid.

Copyright©, Ausgrid.

This publication may only be reproduced with the permission of Ausgrid.

### **Feedback**

Ausgrid invites our customers and stakeholders to provide feedback on this document by sending your comments and suggestions to:

[pricing@ausgrid.com.au](mailto:pricing@ausgrid.com.au)

or:

Manager - Regulation  
Ausgrid  
GPO Box 4009  
SYDNEY NSW 2001

Information on Ausgrid's NUOS tariffs and policies is available from [www.ausgrid.com.au](http://www.ausgrid.com.au).

## CONTENTS

1	INTRODUCTION .....	3
1.1	Overview of Network pricing documents.....	3
1.2	Special arrangements for the 2016-2017 regulatory year .....	3
2	ASSIGNING AND RE-ASSIGNING CUSTOMERS TO PRIMARY TARIFFS AND TARIFF CLASSES .....	4
2.1	Assigning new customers to a primary NUOS tariff and tariff class.....	4
2.1.1	Tariff class assignment.....	4
2.1.2	Primary NUOS Tariff assignment.....	5
2.2	Re-assigning existing customers to a primary NUoS tariff and tariff class .....	5
2.2.1	Annual review and assessment .....	5
2.2.2	Tariff Change Request Application.....	6
3	GENERAL DESCRIPTION OF NUOS TARIFFS .....	7
3.1	Overview of Network tariff components .....	7
3.2	Network Access Charge (NAC).....	7
3.2.1	Applicable tariffs.....	7
3.2.2	NAC details.....	8
3.3	Meter Service Charge (MSC).....	8
3.3.1	Applicable tariffs.....	8
3.3.2	MSC details .....	8
3.4	Single Anytime energy charges .....	8
3.4.1	Applicable tariffs.....	8
3.4.2	Single Anytime energy charge details .....	8
3.5	Block Anytime energy charges.....	8
3.5.1	Applicable tariffs.....	8
3.5.2	Block Anytime energy charge details .....	8
3.6	Time-of-Use (ToU) energy charges.....	9
3.6.1	Applicable tariffs.....	9
3.6.2	ToU energy charge details.....	9
3.7	Capacity charges .....	10
3.7.1	Applicable tariffs.....	10
3.7.2	Capacity charge.....	10
3.7.2.1	Illustrative example of the capacity charge calculation .....	10
3.7.2.2	Illustrative example of the ratcheting of the capacity charge calculation.....	11
3.7.2.3	Arithmetic calculation of demand for multiple connection sites .....	12
3.7.2.4	Reset of capacity charge volume .....	12
3.7.2.5	Retail Transfers .....	12
3.7.2.6	Network tariff advice – power factor correction .....	12
3.7.3	Application of Distribution Loss Factors (DLF) .....	12
3.7.4	Additional tariff specific information .....	13
3.7.4.1	Individually Calculated Tariffs (ICT).....	13
3.7.4.2	Controlled Load tariffs .....	13
3.7.4.3	Temporary supply tariffs .....	13
3.7.4.4	Standby Tariffs (Closed).....	14
3.7.4.5	Transitional tariffs.....	14
	GLOSSARY.....	15
	APPENDIX A – NETWORK TARIFF AND THRESHOLD CHANGE APPLICATION FORM.....	18
	APPENDIX B – CONTROLLED LOAD TARIFFS.....	20
	Tariff Criteria .....	20
	General Requirements.....	20
	Appliance Suitability and Contactor Installation .....	20
	Prohibition of Changeover Switch, or Interconnection between primary and secondary tariffs .....	20

Noise Considerations .....	21
Hot Water Systems (Electric Water Heaters) .....	21
Electric Storage Water Heaters .....	21
Special Conditions for Retirement Villages and Similar Accommodation .....	21
Combinations of Storage Water Heaters .....	21
Electrically-boosted Solar Water Heaters .....	22
Heat Pump Water Heaters .....	22
Other Heating Sources for Water Heaters .....	22
Electric Vehicles .....	22
Electric Vehicle Charging .....	22
Other Equipment .....	22
Special Conditions for Existing Installations .....	22
Existing Water Heaters .....	22
Big Blue Continuous Tariff (Obsolete - Closed) .....	22
Implementation of Controlled Load Switching .....	23
Safe Operation of Load Control Relay .....	23
Smart Time Switch Requirements .....	23
Ausgrid Specific Load Control Schedules .....	24
APPENDIX C – UNMETERED SUPPLY TARIFFS.....	25
APPENDIX D – METERING SERVICES CHARGE (MSC) .....	26
Metering Services.....	26
Capital cost recovery .....	26
Non-capital cost recovery.....	26
APPENDIX E – CALCULATION OF POWER FROM INTERVAL DATA (AUSGRID) .....	28
Power Principle .....	28
APPENDIX F – METHODOLOGY FOR CALCULATING AVOIDED TUOS PAYMENTS .....	29
Background.....	29
Methodology for calculating ATUOS payment.....	29
ATUOS calculation method – “with and without” method .....	29
Metering Considerations .....	31
Interaction with other Embedded Generators.....	32
APPENDIX G – DAYLIGHT SAVING TIME .....	33
Start and End of Daylight Saving Time .....	33

# 1 Introduction

---

## 1.1 Overview of Network pricing documents

This document is Ausgrid's Network Pricing Guide. It provides further information to assist in the application and interpretation of Ausgrid's tariff classes and the tariffs applicable to each class reflected in Ausgrid's 2015/16 Pricing Proposal document.

Every five years, Ausgrid submits a regulatory proposal to the Australian Energy Regulator (AER), which includes proposed capital and operating plans and the funding needed to deliver those plans. The AER reviews the regulatory proposal, considers feedback, and decides how much revenue Ausgrid can recover from its customers to fund its operations. The current AER determination for Ausgrid is available at [www.aer.gov.au](http://www.aer.gov.au).

Ausgrid has submitted a proposed Tariff Structure Statement (TSS) for the period 2017-2019 as required under the National Electricity Rules (NER). The TSS provides stakeholders with a comprehensive understanding of Ausgrid's proposed approach to setting tariffs and an indication of how the structure and level of tariffs may change over the regulatory control period. Ausgrid's current proposed TSS is available at [www.aer.gov.au](http://www.aer.gov.au) and applies from 1 July 2017. On 2 August 2016, the AER issued its draft decision on Ausgrid's TSS. The AER is required to publish its final decision on Ausgrid's TSS on 27 February 2017. Ausgrid is required to develop its pricing proposal for FY2017/18 in accordance with the requirement set out in the final TSS.

Every year, with the exception for 2016/17 regulatory year (see section 1.2 below), Ausgrid is required to submit a pricing proposal to the AER. The pricing proposal document sets out Ausgrid's proposed tariffs and demonstrates how the proposed tariffs comply with Chapter 6 of the NER. Ausgrid's pricing proposal is available at [www.aer.gov.au](http://www.aer.gov.au) or [www.ausgrid.com.au](http://www.ausgrid.com.au). For more information on the distribution pricing arrangements under the National Electricity Rules, refer to [www.aemc.gov.au](http://www.aemc.gov.au).

Ausgrid publishes an annual Network Price List which sets out the applicable prices for each published Network Use of System (NUoS) tariff and supersedes the prices published for the previous financial year. The latest price list is available at [www.ausgrid.com.au](http://www.ausgrid.com.au).

## 1.2 Special arrangements for the 2016-2017 regulatory year

Ausgrid's current AER distribution determination has been set aside by the Australian Competition Tribunal. The setting aside of the current AER distribution determination raised a number of uncertainties regarding Ausgrid's ability to discharge its pricing obligations under the National Electricity Rules. Ausgrid has provided an undertaking in accordance with section 59A of the National Electricity Law (Regulatory Undertaking) to set prices for the 2016/17 regulatory year in accordance with the terms of the Regulatory Undertaking, available at [www.ausgrid.com.au](http://www.ausgrid.com.au). The Regulatory Undertaking sets out Ausgrid's Network Price List for the 2016/17 Regulatory Year which are the tariffs set out in the Ausgrid's 2015/16 Pricing Proposal adjusted to include an amount for changes in the consumer price index. For this reason, the 2015/16 Pricing Proposal should be reviewed for context and explanation for the 2016/17 Network Price List.

Importantly, Attachment 14 of Ausgrid's 2015-2019 distribution determination which sets out the procedures for assigning or reassigning retail customers to tariff classes continues to apply to Ausgrid.

## 2 Assigning and re-assigning customers to primary tariffs and tariff classes

This Section provides a summary of Ausgrid’s procedure for assigning new customers to a default NUOS tariff and for re-assigning existing customers to another NUOS tariff.

This chapter should be read in conjunction with the Tariff Assignment Procedure set out in the applicable AER Determination and the Annual Pricing Proposal, available at [www.aer.gov.au](http://www.aer.gov.au) or [www.ausgrid.com.au](http://www.ausgrid.com.au). If there is any inconsistency between this Chapter and the Tariff Assignment Procedure, the Tariff Assignment Procedure prevails.

### 2.1 Assigning new customers to a primary NUOS tariff and tariff class

Ausgrid’s procedure for assigning new customers to a default NUOS tariff and re-assigning existing customers to another NUOS tariff involves the following two aspects:

- Assigning new customers or re-assigning existing customers to the applicable tariff class given their connection characteristics.
- Assigning new customers or re-assigning existing customers to the applicable NUOS tariff within their correct tariff class.

Both of these aspects to Ausgrid’s tariff assignment and re-assignment procedure are discussed below:

#### 2.1.1 Tariff class assignment

Ausgrid will assign a new customer to a network tariff class by applying the following principles:

- If the supply is unmetered then the customer will be assigned to the Unmetered tariff class. Appendix C provides more detail about unmetered supplies.
- If the customer’s supply voltage as measured at the metering point is either 230V (Single Phase) or 400V (Poly Phase) then the customer will be assigned to the Low Voltage tariff class.
- If the customer’s supply voltage as measured at the metering point is greater than 1 kV and less than 33 kV (typically 5 kV, 11 kV or 22 kV) then the customer will be assign to the High Voltage tariff class.
- If the customer’s supply voltage as measured at the metering point is greater than or equal to 33 kV (typically 33 kV, 66 kV or 132 kV) then the customer will be assigned to the Sub-transmission tariff class.

Ausgrid’s default tariff class assignment procedure is also explained by Table 2.1.

**Table 2.1: Overview of eligibility criteria for assigning customers to tariff classes**

Tariff Class	Nature of Usage	Nature of Connection to Network	
		Metering	Voltage
Low Voltage	Residential or Business	Metered	230V/400V
High Voltage	Business		5kV, 11kV, 22kV
Sub-transmission	Business		33kV, 66kV, 132kV
Transmission <sup>1</sup>	Business		Applicable to any site that is connected to the electricity transmission network.
Unmetered	Business	Unmetered	230V/400V

<sup>1</sup> ~~Subject to Approved in~~ AER Final decision on Ausgrid’s revised Tariff Structure Statement, refer to [www.aer.gov.au](http://www.aer.gov.au)

## 2.1.2 Primary NUOS Tariff assignment

The eligibility criteria underlying Ausgrid's procedure for assigning new customers to primary NUoS tariffs is summarised in Table 2.2.

**Table 2.2: Assignment of new customers to default primary tariffs**

Tariff Class	Nature of Usage	Extent of Usage	NER Meter Type	Tariff code and tariff
Low Voltage	Residential	All	4-6	EA010 Residential Non-ToU
	Business	< 40 MWh per annum	4-6	EA050 Small Business Non-ToU
		40-160 MWh per annum	4-5	EA302 LV 40-160 MWh (System)
		160-750 MWh per annum	≤ 3	EA305 LV 160-750 MWh (System)
		> 750 MWh per annum	≤ 3	EA310 LV >750 MWh (System)
High Voltage	Business	All	≤ 3	EA370 HV Connection (System)
Sub-transmission	Business	All	≤ 3	EA390 ST Connection (System)
Unmetered	Business	All	-	EA401 Public Lighting or EA402 Constant Unmetered or EA403 Energy Light

New LV customers must have an appropriate NER compliant metering installation connected to support the tariff requirements outlined in this price guide and also meet the requirements of Ausgrid's metering policy, ES3 Part A Metering Installation Requirements. By default, these new customers where Type 5 (or better) metering is installed and who expect to consume less than 40 MWh per annum will be placed on either the EA025 or the EA225 network tariffs. Business customers with a 3 phase connection must have a Type 5 (or better) metering installation, which will result them in being placed on the EA302 tariff if their estimated expected annual consumption is less than 160 MWh per annum.

Customers who have a Type 5 meter (or better) installed due to a customer initiated action, such as an upgrade of the switch board that requires a new meter and are assessed to consume above 40 MWh per annum, will be placed on the EA302 tariff either from the date that the new meter is installed or through the annual review process. If the upgraded meter is a 3 phase meter and the customer is a business, then they will also be transferred to EA302 either from the date that the new meter is installed or through the annual review process.

## 2.2 Re-assigning existing customers to a primary NUoS tariff and tariff class

### 2.2.1 Annual review and assessment

Ausgrid is required under Chapter 6 of the National Electricity Rules to undertake an annual review and assessment of NUoS tariffs and tariff classes.

There are a number of circumstances where Ausgrid's annual review and assessment may identify that an existing customer is no longer eligible to remain assigned to their existing NUoS tariff because:

- They have changed their voltage level of supply as measured at the metering point to the extent that they are no longer eligible to remain assigned to their existing tariff class.
- They are assigned to the correct tariff class, but have changed their usage of Ausgrid's electricity network to the extent that they are no longer eligible to remain assigned to their existing NUoS tariff.

To avoid unnecessary transaction costs associated with re-assigning existing customers to another primary NUoS tariff as part of the annual pricing proposal process where the extent of network usage is a relevant factor, Ausgrid will assess the eligibility of an existing customer to remain on their current NUoS tariff on the basis of the existing customer's energy consumption and maximum demand (if applicable) in the preceding 24 months.

In the event that Ausgrid's annual review and assessment identifies existing customers that are no longer eligible to remain assigned to their current primary NUoS tariff, Ausgrid is required to re-assign these customers to another NUoS tariff for the purpose of the next annual pricing proposal.



## 2.2.2 Tariff Change Request Application

Retailers may apply on behalf of a customer to be re-assigned to another NUoS tariff within the customer's applicable tariff class.

It is the responsibility of the retailer to understand the potential NUoS tariff options available to a customer and to submit a tariff change request application to Ausgrid if they wish to re-assign a customer to another NUoS tariff.

Ausgrid requires that all tariff change request applications are made by the customer's retailer in writing with supporting documentation on a "Network Tariff and Threshold Change Application Form" (refer to Appendix A). The completed form should be emailed to: [nemsrpop@ausgrid.com.au](mailto:nemsrpop@ausgrid.com.au)

Ausgrid reserves the right to not process any application if the "Network Tariff and Threshold Change Application Form" is not sent to the email address specified above and/or based on missing or incomplete data.

It should be noted that:

- Ausgrid will only process a tariff change request application from a retailer if the application relates to a customer that has at least 12 months of energy consumption history;
- Ausgrid will process a tariff change request application from a retailer if the application relates to a customer that has not previously applied to be re-assigned to another NUoS tariff in the 12 months prior to the date of the application;
- A tariff change request application from a retailer that relates to a customer requesting to be re-assigned to an individually calculated tariff must be submitted prior to 30 September for the new tariff to apply from 1 July, in order to allow sufficient time for Ausgrid to calculate an appropriate distribution load factor for the tariff (Ausgrid is required under Chapter 6 of the National Electricity Rules to submit forecast Distribution Loss Factors to the AER in March of each year);
- If approved, Ausgrid will re-assign the customer to the new NUoS tariff from the start of the next billing period following the date of receipt of the tariff change request application. Ausgrid does not permit backdating of any change to the customer's NUoS tariff arrangements where a retailer or a third party acting on behalf of the retailer fails to correctly adhere to the process set out in this price guide.

## 3 General description of NUoS tariffs

This Section provides a general description of Ausgrid's NUoS tariffs to assist retailers, customers and other stakeholders to understand the application of Ausgrid's Network Price List for 2016/17 (contained in the Regulatory Undertaking) and particularly, Ausgrid's tariff components, tariff structures and billing arrangements.

### 3.1 Overview of Network tariff components

The components of each primary NUoS tariff are summarised in Table 3.1 below.

**Table 3.1: Summary of Ausgrid NUoS tariff components**

Network Tariff	Network Access Charge	Metering Service Charge	Energy Charge			Capacity Charge
			Single Anytime	Block Anytime	Time-of-Use	
EA010 Residential Non-ToU	✓	✓		✓		
EA025 Residential ToU	✓	✓			✓	
EA030 Controlled Load 1	✓	✓	✓			
EA040 Controlled Load 2	✓	✓	✓			
EA050 Small Business Non-ToU	✓	✓		✓		
EA225 Small Business ToU	✓	✓			✓	
EA302 LV 40-160 MWh (System)	✓	✓			✓	✓
EA305 LV 160-750 MWh (System)	✓				✓	✓
EA310 LV >750 MWh (System)	✓				✓	✓
EA316 Transitional 40-160 MWh (Closed)	✓	✓			✓	✓
EA317 Transitional 160-750 MWh (Closed)	✓	✓			✓	✓
EA325 LV Connection (Standby) (Closed)	✓				✓	✓
EA360 HV Connection (Standby) (Closed)	✓				✓	✓
EA370 HV Connection (System)	✓				✓	✓
EA380 HV Connection (Substation)	✓				✓	✓
EA390 ST Connection	✓				✓	✓
EA391 ST Connection (Substation)	✓				✓	✓
EA401 Public Lighting			✓			
EA402 Constant Unmetered			✓			
EA403 Energy Light			✓			
Individually Calculated Tariffs (ICT)	✓				✓	✓

### 3.2 Network Access Charge (NAC)

#### 3.2.1 Applicable tariffs

NAC applies to all NUoS tariffs with the exception of the Unmetered tariff class tariffs.

### **3.2.2 NAC details**

The NAC is a fixed charge (in cents per day) which is applied to each energised connection point at which energy or demand is recorded. A separate NAC may be applied to each connection point and their associated metering points as determined by Ausgrid. Note that NAC also applies to the secondary tariffs EA030 Controlled Load 1 and EA040 Controlled Load 2.

## **3.3 Meter Service Charge (MSC)**

### **3.3.1 Applicable tariffs**

From 1 July 2015, MSC may apply to the following tariffs:

- EA010 Residential Non-ToU
- EA050 Small Business Non-ToU
- EA030 Controlled Load 1
- EA040 Controlled Load 2
- EA025 Residential ToU
- EA225 Small Business ToU
- EA302 LV 40-160 MWh (System)
- EA316 Transitional 40-160 MWh (Closed)
- EA317 Transitional 160-750 MWh (Closed)

MSC also applies to sites where generation systems (such as solar PV and wind turbines) are connected to the Ausgrid network.

### **3.3.2 MSC details**

Appendix D sets out information behind MSC.

## **3.4 Single Anytime energy charges**

### **3.4.1 Applicable tariffs**

Single Anytime energy charges apply to the following tariffs:

- EA030 Controlled Load 1
- EA040 Controlled Load 2
- EA401 Public Lighting
- EA402 Constant Unmetered
- EA403 Energy Light

### **3.4.2 Single Anytime energy charge details**

The Single Anytime energy charge is a price charged (in cents per kWh) for energy consumed regardless of when the energy is consumed.

## **3.5 Block Anytime energy charges**

### **3.5.1 Applicable tariffs**

Block Anytime energy charges apply to the following tariffs:

- EA010 Residential Non ToU
- EA050 Small Business Non ToU

### **3.5.2 Block Anytime energy charge details**

The Block Anytime energy charge is a price charged (in cents per kWh) for energy consumed regardless of when the energy is consumed, but where the energy charge varies according to the level of energy consumption in a quarterly billing period.

A three block tariff structure applies to tariff EA010 Residential Non-ToU. The first block charge applies to the first 1,000 kWh of consumption per 91 day billing cycle. The second block charge applies to consumption greater than 1,000 kWh and up to 2,000 kWh per 91 day billing cycle. The third block charge applies to any remaining consumption.

A two block tariff structure applies to tariff EA050 Small Business Non-ToU. The first block charge applies to the first 2,500 kWh of consumption per 91 day billing cycle. The second block charge applies to any remaining consumption.

A quarter is defined as being 91 days. Where actual meter read cycles are not equal to 91 days, the first block consumption for both tariffs, and the second block consumption for tariff EA010 Residential Non-ToU, will be pro-rated back to a 91 day basis.

## 3.6 Time-of-Use (ToU) energy charges

### 3.6.1 Applicable tariffs

ToU energy charges apply to the following tariffs:

- EA025 Residential ToU
- EA225 Small Business ToU
- EA302 LV 40-160 MWh (System)
- EA305 LV 160-750 MWh (System)
- EA310 LV >750 MWh (System)
- EA316 Transitional 40-160 MWh (Closed)\*
- EA317 Transitional 160-750 MWh (Closed)\*
- EA325 LV Connection (Standby) (Closed)\*
- EA360 HV Connection (Standby) (Closed)\*
- EA370 HV Connection (System)
- EA380 HV Connection (Substation)
- EA390 ST Connection
- Individually Calculated Tariffs (ICT)

\*Not available to new customers and subject to Ausgrid's approval.

### 3.6.2 ToU energy charge details

A ToU energy charge is a price charged (in cents per kWh) for energy consumed during specific time periods, as set out in Table 3.2. Please refer to Appendix G for a detailed explanation on daylight saving time.

**Table 3.2: Ausgrid NUoS ToU time periods**

ToU Period	Tariff codes	Clock time* and day-type**
Peak	All ToU tariffs	2pm – 8pm on working weekdays
Shoulder	EA025 Residential ToU and EA225 Small Business ToU	7am – 2pm and 8pm – 10pm on working weekdays, and 7am – 10pm on weekends and public holidays
	All other ToU tariffs	7am – 2pm and 8pm – 10pm on working weekdays
Off-Peak	All ToU tariffs	All other times

\*All times take into account Daylight Saving Time during the period gazette by the NSW Government, which is generally from 3am on the first Sunday in October through to 2am on the first Sunday in April.

\*\* Any public holidays that do not apply to the whole of the state of NSW are not considered to be public holidays for the purpose of defining time of use time periods.

## 3.7 Capacity charges

### 3.7.1 Applicable tariffs

Capacity charges apply to the following tariffs:

- EA302 LV 40-160 MWh (System)
- EA305 LV 160-750 MWh (System)
- EA310 LV >750 MWh (System)
- EA316 Transitional 40-160 MWh (Closed)\*
- EA317 Transitional 160-750 MWh (Closed)\*
- EA325 LV Connection (Standby) (Closed)\*
- EA360 HV Connection (Standby) (Closed)\*
- EA370 HV Connection (System)
- EA380 HV Connection (Substation)
- EA390 ST Connection
- (most) Individually Calculated Tariffs (ICT)

\*Not available to new customers and subject to Ausgrid's approval.

### 3.7.2 Capacity charge

A capacity charge is a price applied (in cents per kW or kVA per day) to the maximum half hourly kW or kVA demand reading<sup>2</sup> that occurred in the peak period (that is, between 2pm and 8pm on a working weekday) at a customer's connection point over the billing periods that relate to the previous 12 months including the current billing period. The volume to which the capacity charge is applied is known as the "billable maximum capacity".<sup>3</sup>

#### 3.7.2.1 Illustrative example of the capacity charge calculation

Below is a numerical example to illustrate the calculation of the billable maximum capacity value for a hypothetical customer.

---

<sup>2</sup> Refer to Appendix E – Calculation of Power from Interval Data (Ausgrid) for the calculation of kW and kVA.

<sup>3</sup> Note – Ausgrid reserves the right to apply a nominated maximum capacity value for billing purposes to new large load connections to our electricity network to ensure that these sites contribute equitably to the costs of providing network services to these sites.

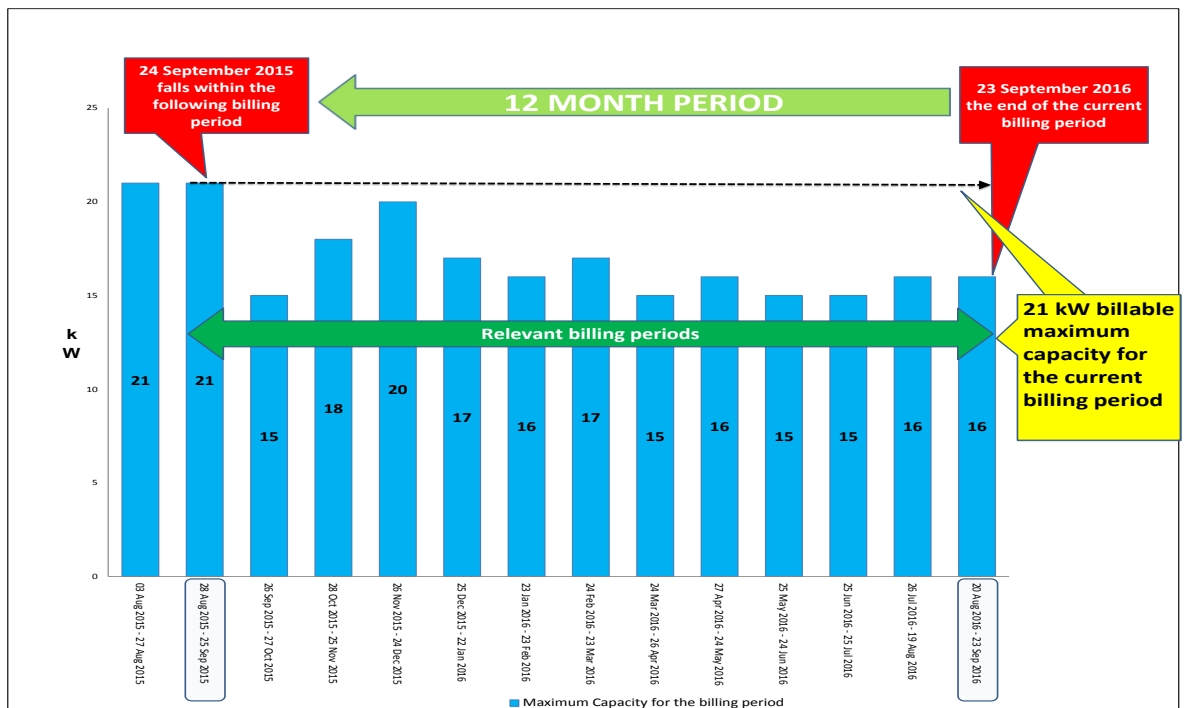

The billable maximum capacity is based on the billing periods that relate to the previous 12 months including the current billing period. The example above is based on a manually read interval meter.

The billable maximum capacity value of 21 kW is assumed to have been recorded on 04/09/2015 from the billing period 28/08/2015 - 25/09/2015.

The billable maximum capacity value of 21 kW for the current billing period is derived from the billing period starting from 28/08/2015 to billing period ending on 23/09/2016.

For type 1 to 4 metered sites, it will be based on strict calendar months. For type 5, which are manually read meters as depicted above, it will be based on the billing periods that cover the 12 month period which are dictated by the meter reading schedule/occurrence.

For all meter types, 1 through to 5, where the site transfers or is permanently disconnected mid-month/read cycle, the oldest relevant billing period that will be included in the calculation will be one that includes the current billing period end date minus 12 months plus one day.

### 3.7.2.2 Illustrative example of the ratcheting of the capacity charge calculation

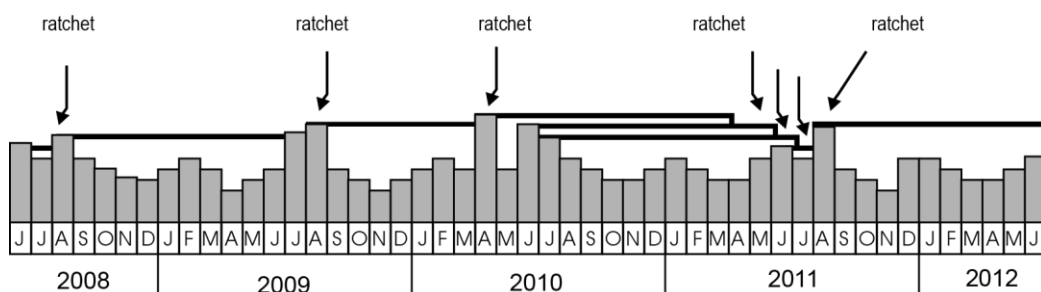

The historical monthly maximum capacity and billable maximum capacity (represented by the bold lines) of a hypothetical customer are shown above.

During each rolling 12 month period, when a peak period maximum demand exceeds the existing billable maximum capacity then a new, higher billable maximum capacity occurs. In the above example this occurs in August 2008, August 2009, April 2010 and August 2011.

Conversely, if at the end of each rolling 12 month period the prior month's billable maximum capacity has not been exceeded, then a new, lower billable maximum capacity occurs. The lower billable maximum capacity is the maximum peak demand recorded in the preceding 12 month period. In the above example this occurs in April 2011, June 2011 and July 2011.

### 3.7.2.3 Arithmetic calculation of demand for multiple connection sites

One capacity charge is applied at each connection point. Coincident or summated capacity charges from multiple connection points are not permitted without the written consent of Ausgrid's Manager – Regulation. It is Ausgrid policy to apply arithmetic demand across monthly meter data streams for capacity charging purposes. Coincident or summated demand is not permitted without the written consent of Ausgrid's Manager – Regulation. The one exception to this rule is in the case of two or three phase supply at a connection point, where coincident demand is applied across the phases to determine the maximum demand.

### 3.7.2.4 Reset of capacity charge volume

In some instances the capacity charge may be reset, either by Ausgrid or at the request of a retailer on behalf of a customer. Retailers are responsible for advising Ausgrid of the customer's capacity reset requirements.

Where a customer plans to permanently reduce their network capacity the customer should provide Ausgrid written notice through their retailer before the planned reduction is to occur. Permanent decreases are a result of the movement in demand due to either planned work to decrease the demand, such as decommissioning the plant or changing plant operations, or when load management equipment is installed. The decrease in capacity will need to be expected to last for at least twelve months before a reset of the Capacity charge will be approved by Ausgrid. A temporary reduction in capacity requirements will not result in a reset of the Capacity charge. The customer will be required to provide relevant documentation that justifies the expected reduction in the level of billable maximum capacity. As an example, in the case of a factory being converted to a warehouse, a Certificate of Compliance Electrical Works (CCEW) will be required as evidence of the decrease in capacity.

The customer will be advised by Ausgrid of the Billable Maximum Capacity level (reset) that will apply.

Ausgrid will also consider resetting the Billable Maximum Capacity in the following circumstances:

- Where a customer has implemented a demand management initiative which will permanently reduce the peak demand at the installation, such as power factor correction; or
- Where an increase in the Billable Maximum Capacity has been caused by a change to the network configuration initiated by Ausgrid;

Customers that exceed their new Billable Maximum Capacity will see an increase in the capacity charge as usual. Customers may only request one reset per year.

A customer wishing to apply for a reset of the Billable Maximum Capacity may make an application to Ausgrid's National Electricity Market Support group, by completing the Network Tariff and Threshold Change Application Form (see Appendix A) and emailing it to: [nemsrpops@ausgrid.com.au](mailto:nemsrpops@ausgrid.com.au).

### 3.7.2.5 Retail Transfers

When a customer transfers, the following historical information will be required by the new retailer to replicate the capacity calculations:

- A full 12 months of history of Peak Capacity values
- A list of NMIs which have multiple connection points (where relevant)

This information can be sourced from the National Electricity Market Support group of Ausgrid contactable by email: [nmi@ausgrid.com.au](mailto:nmi@ausgrid.com.au).

### 3.7.2.6 Network tariff advice – power factor correction

Customers can minimize their billable maximum capacity level by improving the overall power factor of the installation and/or by shifting demand from peak to non-peak periods.

Customers who are considering power factor correction can contact Ausgrid on phone number 131535, or consult the demand management information at [www.ausgrid.com.au](http://www.ausgrid.com.au)

### 3.7.3 Application of Distribution Loss Factors (DLF)

Ausgrid is required under the National Electricity Rules to calculate a Distribution Loss Factor (DLF) for each NUOS tariff. Network charges are calculated on the metered quantities and are not subject to DLF. However, it is the responsibility of Ausgrid to determine and publish DLF.

The DLF are used by retailers in the energy trading and market settlement process to account for electrical losses in the distribution network. The DLF varies depending upon the location and voltage of a customer's connection point.

Similarly, Transmission Loss Factors are also used in the market settlement of energy to take account of electrical losses in the transmission network.

The latest DLF are shown on Ausgrid's Network Price List, which is available from [www.ausgrid.com.au](http://www.ausgrid.com.au).

For more information on Ausgrid's methodology for calculating DLF, refer to our DLF methodology document. This document is available from [www.ausgrid.com.au](http://www.ausgrid.com.au).

### 3.7.4 Additional tariff specific information

#### 3.7.4.1 Individually Calculated Tariffs (ICT)

Customers currently on a published NUoS tariff that have network usage that is greater than 10MW or 40GWh per annum over a period of a full financial year can apply to be re-assigned to an ICT.

The customer application must be submitted to Ausgrid prior to 30 September in the financial year preceding the financial year from which the ICT will apply. This gives Ausgrid sufficient time to calculate an appropriate distribution load factor for the tariff (distribution load factors are required to be submitted by Ausgrid by early March).

#### 3.7.4.2 Controlled Load tariffs

Controlled Load tariffs are secondary tariffs. More detailed criteria and general requirements pertaining to Controlled Load tariffs are set out in Appendix B.

#### 3.7.4.3 Temporary supply tariffs

Temporary supply tariffs apply to installations that are not permanently installed or do not provide a permanent supply to the areas in which they are required. The temporary supply tariff is effectively the appropriate existing tariff allocated to a customer as per the details in Table 3.3.

**Table 3.3: Meters at temporary supplies**

Service Type	Capacity *	Meter	Network Price
One Phase (only)	< 100 A	Type 5	EA025 Residential ToU
2 – 3 Phase	<100 A	Type 5	EA302 LV 40-160 MWh (System)
		Type 4	EA305 LV 160-750 MWh (System)
	> 100 A	Type 3	EA310 LV >750 MWh (System)

\*The capacity of the service is the maximum rating of the cable or busbar service as determined by Ausgrid.

A Network Tariff and Threshold Change Application Form (Appendix A) will have to be submitted for the supply to be considered at a substation price.

The customer is responsible for the costs of installing and dismantling mains, meters and fittings and for the inspection, connection and disconnection of the customer's installation as set out in Ausgrid's publication ES5 *Charges for Network Miscellaneous & Monopoly Services* and ES8 *Capital Contribution Guidelines*.

Temporary supply must be separately metered with Rules compliant meters and will have its own NMI, separate to any permanent supply and will not affect the permanent supply arrangement and its associated NMI.

Coincident demand is not permitted between permanent and temporary connection points.

Where application for temporary supply for the purposes of carrying out experiments in lighting or industrial processes is made in writing and is approved by Ausgrid, supply will be made available at the EA310 LV >750 MWh tariff.



When determining the applicable network charges to be applied, the temporary increase in the maximum power reading (as assessed by Ausgrid) caused by the connection and use of experimental apparatus will be waived, provided that:

(a) Supply will be made available under these conditions only if no alterations to Ausgrid's service or system are involved.

(b) The customer will pay the cost of Ausgrid making only such modifications or additions to its metering equipment as may be necessary for its purposes. However, the customer may arrange for additional metering instruments to be installed by an accredited service provider, the cost of installing and removing these additional instruments to be paid by the customer.

(c) The connection of apparatus under these conditions will be limited to a period of one month unless application for the extension of this period is made in writing and is approved by Ausgrid.

The reconnection of a permanent installation, even for a short period, does not qualify as a temporary supply.

#### **3.7.4.4 Standby Tariffs (Closed)**

Tariffs EA325 LV Connection (Standby) and EA360 HV Connection (Standby) are now closed. This means that no existing or new customers may be assigned or re-assigned to these tariffs except in limited circumstances and at Ausgrid's discretion. Standby supplies are loads not normally connected to the electrical supply system but increase the capacity requirements on the upstream system which must be capable of supplying the standby load in addition to normally supplied loads. In accordance with the current AEMO National Metering Identifier Procedure document, the standby connection point must be assigned a separate NMI to the normal supply point.

The standby supply prices have four charging components. These consist of a fixed charge, and peak, shoulder and off-peak energy charges. The fixed charge is designed to recover the cost of the feeder, even while no capacity is being used. Whether or not the customer uses the supply, the customer will be charged a fixed daily charge for the provision of the supply.

The terms and conditions set out in the connection agreement of a standby supply may vary according to the circumstances and such customers may be required to enter into a connection agreement. Ausgrid reserves the right to reassess existing standby supplies at any time for their impact on the electricity system and apply revised or new standby prices according to current metering and pricing methodologies. In general standby supplies should not be used as the standard supply for a customer.

A Capital Contribution usually applies to any connection as set out in Ausgrid's publication ES8 Capital Contributions and Recoverable Work Guidelines.

Electricity supplied under this tariff may be used by the customer for all agreed purposes for which electricity may be required to be used during outages of the normal means of supply at the customer's premises.

For customers requiring standby supply from Ausgrid where agreements have already been entered into which do not comply with these requirements, the existing services are retained unless a change is specifically requested by the customer.

#### **3.7.4.5 Transitional tariffs**

Ausgrid is required to undertake an annual review to ensure that retail customers are correctly assigned to the appropriate NUoS tariff. If, as a result of undertaking this review, Ausgrid identifies that customers would receive unacceptable network bill outcomes as a result of being transferred to their appropriate tariff, Ausgrid reassigns such customers to an appropriate transitional NUoS tariff.

# Glossary

---

Ancillary network services	Non-routine services provided to individual customers on an “as needs” basis. Examples of these services include providing design related information for connections to be made to our network, special meter reads and site establishment fees.
AEMC	Australian Energy Market Commission
AEMO	Australian Energy Market Operator
AER	Australian Energy Regulator
Basic accumulation metering	Accumulation meters keep track only of the total accumulated electricity usage. Customers are charged the same amount regardless of when the electricity is used.
Billable Maximum Capacity	Has the meaning given to the term in section 3.7.2.
Billing period	The time span covered by a network bill.
Block Tariff	A tariff with a structure that applies a different price for energy consumption beyond specified energy consumption threshold or thresholds.
Business customer	All customers that do not satisfy the definition of a residential customer.
CCF	Climate Change Fund
Charging parameter	Pricing component that makes up a tariff.
Cost Reflective Network Price	See Individually Calculated Tariff
Current Transformer (CT) connection	A connection where the transformer for use with meters and/or protection devices in which the current in the secondary winding is, within prescribed error limits, proportional to and in phase with the current in the primary winding.
Customer class	Refer to Tariff class
Determination	A decision by the AER that determines the revenue allowance for network service providers under the National Electricity Rules.
Distribution Loss Factor	Refer to the definition set out in Ausgrid’s methodology for forecasting distribution loss factors. This document is available from <a href="http://www.ausgrid.com.au">www.ausgrid.com.au</a>
Distribution Network Service Providers	A person who engages in the activity of owning, controlling or operating a transmission or distribution system and who is registered by AEMO as a Network Service Provider.
Distribution-connected sites	Customers that are connected to the electricity distribution network.
DUOS	Distribution Use of System
Dynamic peak prices	This is a charging parameter that applies a price, expressed on a cents per kWh basis to energy consumption during a dynamic peak event.
Dynamic peak event	The dynamic peak energy charge is applied to consumption during the specific peak period (e.g. 1pm to 8pm) during the dynamic peak event. There are typically only around 12 dynamic peak events called in a financial year.

Efficiency	Signifies a level of performance that describes a process that uses the lowest amount of inputs to create the greatest amount of outputs.
Existing customer	A customer that exists at the time that Ausgrid undertakes the annual review and assessment in relation to the relevant pricing proposal.
Fixed charge	A charging parameter expressed in cents per day. Also known as Network Access Charge.
High voltage tariff	A tariff that applies to connections that are connected at high voltages 5kV, 11kV or 22kV (as measured at the metering point) that is neither a Sub-transmission nor an individually calculated tariff.
Interval meter	A meter that records how much electricity is used every 30 minutes.
Individually calculated tariff	This is a tariff that is calculated on a site-specific basis.
Low voltage tariff	A tariff that applies to connections that are connected at low voltages 230V or 400V (as measured at the metering point).
LRMC	Long Run Marginal Cost
Metering point	The physical point of connection between the Consumers Mains and the electrical network. Each separate overhead or underground service is a separate connection point. Each separate busbar or direct cable supply from a single substation is a separate connection point, e.g. two busbar supplies equal two connection points.
Metering services	Services that measure the customers' energy consumption and can assist customers to better understand and manage their energy usage.
National Electricity Law	The National Electricity Law set out in the schedule to the National Electricity (South Australia) Act 1996 (SA) and applied in each of the participating jurisdictions.
National Electricity Rules	Refers to the National Electricity Rules (NER) which governs the operation of the National Electricity Market. The Rules have the force of law, and are made under the National Electricity Law.
Network services	Transmission service or distribution service associated with the conveyance, and controlling the conveyance, of electricity through the network.
New customer	A customer that does not satisfy the definition of an existing customer.
NUOS	Network Use of System price, which is composed of DUOS, TUOS and CCF prices.
Phase	As defined in the <i>Service and Installation Rules of New South Wales August 2012</i> .
Price cap	A price control mechanism
Primary tariff and secondary tariff	A primary tariff applies to the principal load of the customer, whereas a secondary tariff applies to separately metered loads on a controlled load circuit which is a controlled supply service, such as off-peak hot water or small scale generation systems. A secondary tariff is only available to a customer where a primary tariff is also in place.
Public lighting services	Services that involve maintaining and improving the standards of streetlights on behalf of local councils, community associations and statutory authorities across Ausgrid's network.

Regulatory Undertaking	Undertaking given to the Australian Energy Regulator by Ausgrid for the purposes of s.59A of the National Electricity (NSW) Law dated 13 May 2016.
Residential Customers	A customer that is assigned to the low voltage tariff class that uses their connection to Ausgrid's electricity network for domestic purposes (e.g. watching television, personal computer usage) except where the use of the network is predominantly for the purpose of obtaining a commercial financial gain.
Single phase connection	Refer to Phase
Sub-transmission voltage tariff	A tariff that applies to connections that are connected at sub-transmission voltages 33kV or greater (as measured at the metering point).
Substation tariff	This tariff is available to customers who are connected to a Transmission Connection Point Substation with distribution assets dedicated to service only their site.
Tariff	The monetary value assigned to individual charging parameters (i.e. cents per kVA or cents per day).
Tariff class	A class of retail customers for one or more direct control services who are subject to a particular network tariff or particular network tariffs as defined in the National Electricity Rules.
Tariff code	A unique code that identifies each different network tariff.
TSS	Tariff Structure Statement referred to in clause 6.18.1A in the National Electricity Rules that has been approved by the AER for that Distribution Network Service Provider.
Three phase connection	Refer to Phase
Time of Use (TOU) tariff	A tariff with a structure that applies a different price for energy consumed at times of the day.
Transitional tariff	A tariff that may be available for a defined period following changes in the network pricing structures.
Transmission-connected sites	Customers that are connected to the electricity transmission network.
TUOS	Transmission Use of System
Type 5 meter	A metering installation containing an electronic meter, or meters, capable of recording electrical energy consumption in 30 minute market intervals in accordance with the NER. Such meters are read manually by meter readers. Data is down-loaded via probes into a hand-held data collection device carried by Ausgrid meter readers. Also known as an MRIM, ToU or interval meters.
Type 6 meter	A metering installation containing a meter, or meters, (electronic or electromechanical) capable of recording cumulative electrical energy consumption only. Such meters are read manually by Ausgrid meter readers who record the total cumulative consumption readings displayed on the Type 6 meter register. All meters can support a Type 6 Installation, but they are predominantly installed with mechanical meters or simple electronic meters. Also known as BASIC, Flat Rate or accumulation meters.
Unmetered tariff	A tariff for unmetered supply
2015/2016 Pricing Proposal	Ausgrid's Pricing Proposal for the 2015/16 which forms the basis of the network prices for 2016/17 regulatory year in accordance with the Regulatory Undertaking.

# Appendix A – Network Tariff and Threshold Change Application Form

## Network Tariff and Threshold Change Application Form

Customer / Business Name: ..... NMI .....

Street Number ..... Street Name .....

City/Town ..... Postcode .....

Additional Site Information: .....

Customers e-mail address .....

Name ..... Signed (Customer).....

**1. NMI Load/Consumption:** Tick  the box of the applicable load (Mandatory)

Below 40MWh p.a.    Between 40 and 160 MWh p.a.    Between 160 and 750 MWh p.a.    Over 750MWh p.a.

**2. Network Tariff:** Tick  the box of the requested tariff

- |  |  |
|--|--|
| <b>2A.</b> <input type="checkbox"/> Residential ToU Price            | The customer confirms this NMI has annual energy consumption below 160 MWh for residential use and requests the Residential ToU network price.   |
| <b>2B.</b> <input type="checkbox"/> Residential Non ToU Price        | The customer confirms this NMI has annual energy consumption below 160 MWh for residential use and requests the Residential Non ToU network price.   |
| <b>2C.</b> <input type="checkbox"/> Small Business ToU Price         | The customer confirms this NMI has annual energy consumption below 40 MWh for business use and requests the Small Business ToU network price.  |
| <b>2D.</b> <input type="checkbox"/> Small Business Non ToU Price     | The customer confirms this NMI has annual energy consumption below 40 MWh for business use and requests the Small Business Non ToU network price.  |
| <b>2E.</b> <input type="checkbox"/> LV 40-160 MWh Price              | The Customer confirms this NMI has annual energy consumption of between 40 MWh and 160 MWh and requests the LV 40-160 MWh network price.   |
| <b>2F.</b> <input type="checkbox"/> LV 160-750 MWh Price             | The Customer confirms this NMI has annual energy consumption of between 160 MWh and 750 MWh and requests the LV 160-750 MWh network price.   |
| <b>2G.</b> <input type="checkbox"/> LV >750 MWh Network Price        | The Customer confirms this NMI has annual energy consumption of more than 750 MWh and requests the LV >750 MWh Network Price   |
| <b>2H.</b> <input type="checkbox"/> HV Connection (Substation) Price | The Customer requests this site receive the HV Connection (Substation) Network Price. Fed from the Transmission Connection Point Substation No. .... Please supply with this application supporting documentation detailing eligibility for application of the substation price.   |
| <b>2I.</b> <input type="checkbox"/> ST Connection (Substation) Price | The Customer requests this site receive the ST Connection (Substation) Network Price. Fed from the Transmission Connection Point Substation No. .... Please supply with this application supporting documentation detailing eligibility for application of the substation price.   |
| <b>2J.</b> <input type="checkbox"/> Cost Reflective Tariff Price     | The customer requests a Cost Reflective Tariff price. The connection point must have exceeded 10 MW on more than three occasions or 40 GWh consumption over a 12 month period.   |
| <b>2K.</b> <input type="checkbox"/> Transmission Connected Price     | The customer requests a Transmission Connected Network price (CRNP). Directly connected to the Transmission Connection Point Substation No. .... without the use of any distribution assets. Please supply with this application supporting documentation detailing eligibility for application of the Transmission Connected price. |

3. **Co-incident Demand and Capacity Reset:** Tick  the box of the applicable request

3A.  **Co-incident Demand across multiple meters at a single connection point (NMI)**

The Customer request this connection point be examined to receive Co-incident Demand and to be configured to meet the Code NMI Procedure requirements. If the request is not approved by Ausgrid, the connection point will receive Arithmetic Demand for the meter data streams

3B.  **Capacity Reset**

The customer requests that the Billable Maximum Capacity value be reset to a level other than the prior 12 month peak.

Reason for the capacity reset: .....

.....  
When submitting a capacity reset request, please provide supporting evidence for the reason mentioned.

4. **Re-Classification:** Tick  the box of the requested Re-Classification

4A. **NMI Re-Classification**

- Small Where consumption over the last 12 months is below 160MWH  
 Large Where consumption over the last 12 months is 160MWH

4B. **Customer Threshold Code – Business Customer Re-Classification**

- Low Where consumption over the last 12 months is below 100MWh  
 High Where consumption over the last 12 months is above 100MWh

The request is endorsed by the customer's **Retailer of Choice** (Not required for business customers directly requesting a change to the customer threshold code)

Retailer Name ..... Name (please print): .....

Title: ..... Signed (Retailer).....

Date: ...../...../..... Telephone (Direct line): ..... E-mail: .....

Postal Address: .....

City / Town ..... Post Code .....

*NOTE: The above request, if approved, will not be backdated and will apply from the start of the next billing period.*

**E-mail address to send requests**

The correct e-mail address must be used at all times, if a request is received in the incorrect e-mail address, Ausgrid cannot guarantee a response.

EMAIL to - [nemsrpop@ausgrid.com.au](mailto:nemsrpop@ausgrid.com.au)

**Fax number (Only if unable to submit the request via e-mail):**

FAX – (02) 9277 3560

## Appendix B – Controlled load tariffs

---

### Tariff Criteria

Controlled Load tariffs are secondary tariffs and can only be applied at installations with one of the following primary tariffs:

- EA010 Residential Non ToU
- EA050 Small Business Non ToU
- EA025 Residential ToU
- EA225 Small Business ToU
- EA302 Low Voltage 40-160 MWh
- EA316 Transitional 40-160 MWh

Secondary tariffs apply to those separately metered loads that are controlled or interrupted in accordance with this document. A secondary controlled load tariff is not permitted at Type 1-3 metering installations.

These secondary tariffs apply to electricity used for operating appliances covered by this document, provided that they comply with the requirements specified. The periods of use of these appliances will be determined by Ausgrid and the load will be controlled at times which may vary from day to day to meet network requirements.

The EA030 Controlled Load 1 tariff is available for supply that is usually connected for at least six hour duration between 10pm and 7am. Controlled Load 1 switching times may be varied at the discretion of Ausgrid.

The EA040 Controlled Load 2 tariff is available for supply that is usually connected for at least sixteen hours per day, including at least six hours between 8pm and 7am and at least four hours between 7am and 5pm. Controlled Load 2 switching times may be varied at the discretion of Ausgrid.

### General Requirements

#### Appliance Suitability and Contactor Installation

Unless otherwise approved by Ausgrid, the following requirements shall be complied with.

- The hours of availability of supply must suit the intended use of the appliance.
- Load control equipment shall comply with the requirements of the NSW Service and Installation Rules of NSW, Section 4.11.3 'Load Control Equipment'.
- The load control device may be contained within the electricity meter so long as the controlled load is resistive, single phase and does not exceed 25 Amp and the total load on the meter does not exceed the current rating of the meter.
- For appliances greater than 10 kW load, please refer to Ausgrid for approval. Contact details are as per ES1 document.

#### Prohibition of Changeover Switch, or Interconnection between primary and secondary tariffs

Any change-over switch, interconnection arrangement or device which would enable appliances, generation or energy storage systems to be interconnected or switched between controlled load and non-controlled load tariffs is not allowed. This includes traditional changeover switches as well as any changeover or interconnection functionality in other equipment (for example, Uninterruptible Power Supply (UPS) units, inverter equipment, or home energy storage units).

Where a consumer desires to charge energy storage batteries using lower cost energy, and to discharge them to displace higher cost energy, the recommended solution is to do so by utilising a Time of Use principal tariff.

## Noise Considerations

Consideration should be given to relevant noise regulations before making a commitment to connect an appliance to a controlled load tariff. The NSW Protection of the Environment (Noise Control) Regulation 2008 specifies restrictions on the hours of operation of appliances that can be heard within a habitable room in any other residential premises. Appliances include heat pump water heaters, air conditioners and swimming pool pumps. Further inquiries about the noise control regulation can be made to the NSW Government (Office of Environment and Heritage) or the NSW Environmental Protection Agency.

## Hot Water Systems (Electric Water Heaters)

### Electric Storage Water Heaters

Supply at the Controlled Load 1 or 2 tariffs is available for use with electric storage water heaters with rated hot water delivery and heating element combinations that comply with the following table.

**Table B.1: Eligibility Criteria for Controlled Load 1 and 2 Tariffs**

Total Rated Hot Water Delivery Litres	Main Element Rating (kW)	
	Controlled Load 1 (EA030)	Controlled Load 2 (EA040)
From 100L to less than 250L	Not eligible	4.8*
From 250L to less than 315L	3.6	4.8*
From 315 to less than 630L	4.8*	4.8*
630L or greater	Required to heat in 9 hours	Determined by Ausgrid

\*Special Condition for Newcastle and Hunter Regions, existing installations may use 3.6 kW elements

The main element(s) will be controlled so that supply is available only during hours determined by Ausgrid.

### Special Conditions for Retirement Villages and Similar Accommodation

Table B.2 sets out the reduced minimum rated hot water delivery levels for self-contained and separately metered accommodation.

**Table B.2: Eligibility Conditions for Retirement Homes**

Maximum Number of Occupants in Premises	Minimum Rated Hot Water Delivery		
	Controlled Load 1	Controlled Load 2	Minimum Rating
One	80 litres	80 litres	3.6kW
Two	125 litres	80 litres	3.6kW

### Combinations of Storage Water Heaters

Controlled Load tariffs are available for combinations of storage water heaters dependent on the following conditions being met:

- The combined rated hot water delivery must meet the minimum requirements for the particular tariff.
  - The rated hot water delivery of any heater must be 100 litres or greater.
  - The combined total of the heating elements must be 4.8 kW or greater.
  - The combined rating of the heating element is to comply with the conditions of the tariff.
  - Where an additional water heater is being installed and the above three conditions are fulfilled, the usual number of heating hours available for the first heating element should be taken into account in selecting the rating of the additional heating element.
- If the tanks are paralleled to a common hot water line, they will be considered as one. (For example, tank volume and element ratings are the sum of the individual ratings.)



## **Electrically-boosted Solar Water Heaters**

Electrically boosted solar storage water heaters will be supplied at the Controlled Load tariff under similar conditions to other types of electric storage water heaters. The rated hot water delivery will include the electrically heated and solar sections of the unit.

## **Heat Pump Water Heaters**

Heat pump storage water heaters may be supplied by Controlled Load tariffs provided that:

- For connection to Controlled Load 1, a heat pump storage water heater shall be capable of recharging ( $\Delta t = 50 \text{ deg C}$ ) at least 250 litres in 6 hours.
- For connection to Controlled Load 2, a heat pump storage water heater shall be capable of recharging ( $\Delta t = 50 \text{ deg C}$ ) at least 100 litres in 6 hours.

## **Other Heating Sources for Water Heaters**

Controlled Load tariffs are not available to electrically boosted water heaters where gas, kerosene or other types of fuel are used as the primary source of heating.

## **Electric Vehicles**

### **Electric Vehicle Charging**

Controlled load tariffs are available for the charging of electric vehicles where an electric vehicle special plug/ socket arrangement – example SAE J1772 (non-standard plug/socket outlet) is used on the vehicle end and the charging equipment or cable is hard-wired on the supply end.

### **Other Equipment**

The following equipment may be operated on either Controlled Load 1 or 2, provided that the appliances are permanently connected, (connection by means of standard plug/socket outlets is not acceptable). There is no minimum rating requirement for the appliance. For equipment in this category a label shall be installed at the point of hard wired connection of the appliance. The intention of the label is to alert a service technician or new owner/occupier to the fact that the appliance is supplied via a controlled load circuit. The label shall read “Supplied from Controlled Load Circuit” or similar.

- Space heaters (e.g. underfloor heating, thermal storage) and ice thermal storage
- Swimming pool equipment, i.e. pool pumps, water heaters for pools, spas and turbo tubs
- Dishwashers, clothes dryers, washing machines and air conditioners
- Other appliances approved by Ausgrid

### **Special Conditions for Existing Installations**

Storage water heaters and thermal storage space heaters, in premises previously supplied at any previous obsolete Controlled Load tariff, are eligible for supply at one of the current Controlled Load tariffs, subject to the approval of the installation by Ausgrid and the following requirements.

#### **Existing Water Heaters**

Provided the heating elements comply with the requirements, the following are permitted:

- Existing water heaters formerly supplied at an obsolete tariff may be replaced by heaters of similar or increased capacity and supplied at the current appropriate Controlled Load tariff.
- Existing water heaters that were eligible for supply at, but not necessarily connected at one of the obsolete controlled load tariffs at the time of installation may be supplied at the current appropriate Controlled Load tariff.

Existing units with 3.6kW elements are satisfactory. It is recommended that replacement water heaters utilise the same element rating as the previous unit provided that the volume of the unit remains the same.

#### **Big Blue Continuous Tariff (Obsolete - Closed)**

The Big Blue Continuous tariff is a product that is no longer offered by Ausgrid. For any existing hot water systems with boosting elements, customers will be charged at the controlled load rate for

both the top and bottom heating elements. The bottom element will be available during controlled load times and the top element will be available at any time.

## **Implementation of Controlled Load Switching**

Historically Ausgrid, and its predecessors, have owned and operated the load control units that have implemented the Controlled Load switching at the customers' premises. With the advent of multiple metering providers for the residential market (under the Power of Choice Rules change) Controlled Load tariffs can be realised with smart time-switch functionality delivered by independent, AEMO accredited Metering Providers with the condition that (a) the obligations of "Safe Operation of Load Control Relay" (set out below) are accepted and (b) the Service Levels as described below under "Smart Time Switch requirements" are met. Deviation from these requirements is not permitted unless agreed to in writing by Ausgrid.

### **Safe Operation of Load Control Relay**

The Metering Provider shall ensure the safe operation of the Load Control Device by utilising only relays that comply with AS62052.21, with respect to the following minimum performance:

- ( $U_n$ ) of 207V – 264V and ( $f_n$ ) of 49-51Hz
- Temperature: -10°C to +55°C and Relative humidity of annual mean of <75 % with individual days up to 95%
- ( $U_c$ ) Rated Breaking Voltage 276V
- ( $I_c$ ) Rated Breaking Current minimum of 25A single phase resistive
- Short Circuit performance (at 7kA and 3kA) as per the Standard
- Number of operations (30,000) as per the Standard

### **Smart Time Switch Requirements**

Metering Providers delivering smart time switch functionality shall comply with the following requirements:

- The hardware shall achieve clock accuracy at the same level as the associated advanced meter.
- The hardware shall support a current load control schedule and support a future load control schedule applicable on a future schedule activation date (after deployment). The load control schedule shall be re-configurable.
- Each load control schedule shall support four switching programs that are defined in terms of day type, and season. The day type means applicable days of the week. The seasons means periods of the year. The seasons are defined such that transitions can be achieved either (a) at a fixed date or (b) on a day of month (e.g. first Sunday in October). Each switching program is described by up to two start-times, and matching finish-times. All start times share a common randomised delay start. The start time and finish time is described in 24 hour time - hours and minutes – (hh:mm) – and in Australian Eastern Standard (AEMO) time. The Randomised Delay Start is described as a randomised period of maximum between 0 and 300 minutes (configurable at one minute intervals).
- The hardware's randomisation method shall be selectable between being set (1) once at time of initial configuration and maintained until next configured; or (2) at every switching event. In each case, the randomisation shall apply such that the deployed population, to which the randomisation applies, demonstrates a rectangular statistical distribution of delay across the period.
- At Loss of Supply, the Switch Position is set to OFF, prior to meter shut-down. After supply restoration, the Return to Schedule shall be configurable to apply either (a) immediately or (b) after a randomised delay configurable between 1 and 300 minutes.
- The hardware shall have the capability of responding to a remote override command that can temporarily suspend the load control schedule in the off or on position and when commanded, return to schedule in a progressive fashion. The expectation is that the Metering Coordinator / Metering Provider shall make available the functionality such that when requested by the Network, that the override can apply to all devices in a defined area.
- The hardware may support a Local Boost (load control schedule manual override with load control switch immediately forced to ON position) for the specific purpose of commissioning and fault-finding only. If activated the local boost shall time out at or before the next scheduled switching event. Such local boost facility is for technician use only and shall NOT be accessible to the customer.

## Ausgrid Specific Load Control Schedules

- The Load Control Schedule for: Network Tariffs EA030 Controlled Load 1 and EA040 Controlled Load 2:

**Table B.3: Load Control Schedule for Ausgrid's Controlled Load Network Tariffs**

Switching Program	Load Control Schedule Controlled Load 1 (EA030)	Load Control Schedule Controlled Load 2 (EA040)
Winter	1st Sun Apr – 1st Sun Oct Start Time 22:00 Finish Time 07:00 Randomised Delay Start 180min	1st Sun Apr – 1st Sun Oct Start Time 20:00 Finish Time 17:00 Randomised Delay Start 180 min
Spring		1st Sun Oct – 1 Nov Start Time 19:00 Finish Time 16:00 Randomised Delay Start 180 min
Summer	1st Sun Oct – 1st Sun Apr Start Time 21:00 Finish Time 06:00 Randomised Delay Start 180min	
Peak Summer		1 Nov – 1st Sun Apr Start Time 19:00 Finish Time 14:00 Randomised Delay Start 180 min

- Clock accuracy shall maintain  $\pm 20s$ .
- Randomisation Method shall achieve statistically rectangular distribution.
- Loss of Supply Switch Position shall revert to OFF position prior to shut-down of meter and Return to Schedule after a randomised delay of 180 minutes after supply restoration.

The Suspend Load Control Schedule function, when requested, is expected to reach 80% of devices within 5 minutes.

## Appendix C – Unmetered supply tariffs

---

Unmetered tariffs apply to network customers that are not required to install a meter to measure the flow of electricity in a power conductor and accordingly there is a requirement to determine by other means the energy data that is deemed to flow in the power conductor.

Ausgrid in consultation with AEMO will determine whether a network customer is not required to install a meter in their premise by considering a broad range of factors, such as:

- the load pattern is predictable;
- for the purposes of settlements, the load pattern can be reasonably calculated by a relevant method set out in the metrology procedure;
- it would not be cost effective to meter the connection point taking into account:
  - the small magnitude of the load;
  - the connection arrangements; and
  - the geographical and physical location.

The network tariff applicable to different types of unmetered supplies are set out in the Network Price List. This document is available from [www.ausgrid.com.au](http://www.ausgrid.com.au).

A decision to assign a network customer to an unmetered tariff does not limit Ausgrid's ability to require that this site is metered in the future.

Unmetered sites can be classified as "market" or "non-market". The difference is that market sites have had their loads independently assessed and registered by AEMO meaning that the customer can have choice of retailer. For "non-market" loads, the retailer can only be the local retailer, Energy Australia. To convert from "non-market" to market the customer must follow a set process. Detail can be supplied upon request to [nbilling@ausgrid.com.au](mailto:nbilling@ausgrid.com.au).

For further Type 7 connection information, see ES1 - Customer Connection Information which is available on the Ausgrid website at [www.ausgrid.com.au](http://www.ausgrid.com.au).

## Appendix D – Metering Services Charge (MSC)

---

### Metering Services

Metering services relate to the provision, operation and maintenance of Type 5 and 6 metering equipment, and include:

- Meter provision – the capital costs of purchase of metering equipment;
- Meter maintenance – activities to inspect, test, maintain, repair and replace meters;
- Meter reading – the quarterly or other regular reading of type 5 & 6 meters; and
- Meter data services – services for the collection, processing, storage and delivery of metering data and the management of National Metering Identifier (NMI) standing data in accordance with the rules.

To recover the costs of the above services, the MSC has been divided into two components:

- A capital component – metering asset base (MAB) recovery, item 1
- A Non Capital Component - maintenance charge including operating expenditure and tax, items 2 through 4.

### Capital cost recovery

The application of the capital component of MSC will be determined by who originally funded the meters (i.e. the customer directly or smeared across all Ausgrid Network customers with metering installed prior to 1 July 2015). From 1 July 2015, Ausgrid will charge an up-front fee to cover metering hardware for all new and upgraded metering connections where the customer requires an Ausgrid Type 5 or 6 metering installation.

Where it is a new connection the capital component of the MSC will not apply. Where it is an upgrade and the customer did not pay for the meters originally (i.e. meters installed prior to 1 July 2015) the capital component will continue to apply. For all other connections the capital component will apply.

The rate of the capital component to be applied will be determined by the network tariff/s that is/are assigned to the NMI.

Where both capital and non- capital charges are applicable they will be charged at a combined rate.

### Non-capital cost recovery

Ausgrid will charge a maintenance metering service charge for all NMI's where Ausgrid provides type 5 & 6 metering services. Ausgrid will be nominated as Responsible Person, Meter Provider and Meter Data Provider for the NMI in the National Electricity Market. The rate of the non-capital component will be determined by the network tariff/s that is/are assigned to the NMI.

Where both capital and non-capital charges are applicable they will be charged at a combined rate.

**Table D.1: MSC Summary Table**

Charge	Description	When charged
Existing Connections Capital Charge Non-Capital Charge	<p>Charge will be applied to all existing sites where Ausgrid funded the metering equipment and is the market metering service provider.</p> <ul style="list-style-type: none"> <li>➤ Responsible Person (RP) = ENERGYAP</li> <li>➤ Meter Data Provider (MDP) = TCAUSTM</li> <li>➤ Meter Provider B (MPB) = TCAMP</li> <li>➤ Meter Provider C (MPC) = TCAUSTM</li> </ul> <p>Charge includes ACS metering related operating costs and tax</p>	<p>Will not apply where Ausgrid ceases to be the Metering Service Provider.</p> <p>Ausgrid will apply the MSC as a daily charge.</p>
Existing Connections Capital Charge Only	<p>Charge will be applied to all existing sites connected prior to 1 July 2015, where existing Ausgrid funded Type 5 or 6 metering equipment has been replaced by a Type 4 metering installation, to recover the costs of the regulated Metering Asset Base (MAB).</p>	<p>Ausgrid will apply the MSC as a daily charge.</p>
New Connections Non-Capital Charge Only	<p>Charge will be applied to all new or customer instigated upgraded sites where the customer has funded the metering equipment and Ausgrid is the market metering service provider.</p> <ul style="list-style-type: none"> <li>➤ Responsible Person (RP) = ENERGYAP</li> <li>➤ Meter Data Provider (MDP) = TCAUSTM</li> <li>➤ Meter Provider B (MPB) = TCAMP</li> <li>➤ Meter Provider C (MPC) = TCAUSTM</li> </ul> <p>Charge includes ACS metering related operating costs and tax for new connections</p>	<p>Will not apply where Ausgrid ceases to be the Metering Service Provider.</p> <p>Ausgrid will apply the MSC as a daily charge.</p>

## Appendix E – Calculation of Power from Interval Data (Ausgrid)

Interval meters that comply with the National Electricity Rules record kWh and kvarh consumption in 30-minute blocks aligned with the hour and half hour – and in Australian Eastern Standard Time (AEST). These are also called Trading Intervals. For example, kWh consumption between 11:00 and 11:30 is a trading interval. Similarly, 11:30-12:00 is a trading interval.

The NEM also allocates Data Stream Identifiers to correctly tag the data from the meters:

Import kWh (real energy generation by customer)	B
Export kWh (real energy consumption by customer)	E
Import kvarh (leading reactive energy)	K
Export kvarh (lagging reactive energy)	Q

Network Capacity Charges are based on the Real Power (kW) or Apparent Power (kVA). kW can be derived directly from kWh. However Apparent Power requires an intermediate calculation, explained by the Power Triangle diagram, which describes the relationship between all three types of power. It also describes the term of Power Factor.

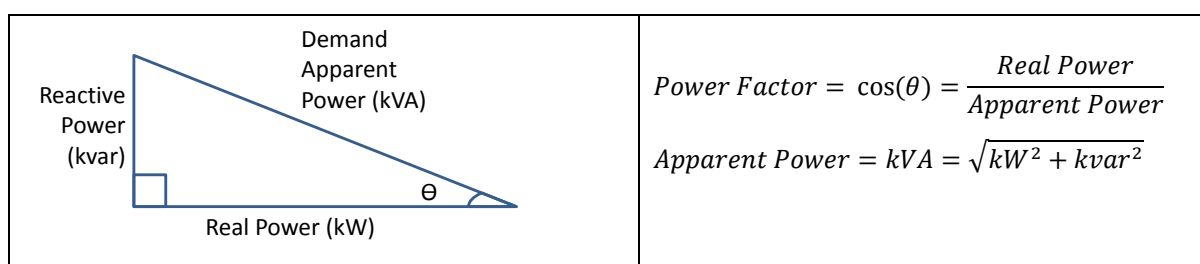

### Power Principle

A customer's maximum power is a measure of the capacity that must be provided by the network. Power has two components, termed real and reactive.

- The Real Power is that which performs useful work, such as providing heating and motion.
- The Reactive Power component is necessary for the flow of real power, and is part of the total demand upon the supply system. The distribution network must be built to carry the Apparent Power.

Reactive power typically results from the inductive loads such as coils in industrial AC inductive motors and transformers. It is the inductance of the coils that causes the difference between the real power and the apparent power.

To determine the average apparent power for a given 30-minute interval, the following calculations are made:

$$\text{kW} = \frac{\text{kWh}_{30 \text{ min}}}{0.5} = 2 \times \text{kWh}_{30 \text{ min}}$$

$$\text{kvar} = \frac{|\text{kvarh}(\text{lag})_{30 \text{ min}} - \text{kvarh}(\text{lead})_{30 \text{ min}}|}{0.5} = 2 \times |\text{kvarh}(\text{lag})_{30 \text{ min}} - \text{kvarh}(\text{lead})_{30 \text{ min}}|$$

$$\text{kVA} = \sqrt{\text{kW}^2 + \text{kvar}^2}$$

In terms of NMI data stream suffixes, this can be simplified to the following calculation for each **30-minute** interval:

$\text{kW} = 2 \times E$
$\text{kVA} = 2 \times \sqrt{E^2 + (Q - K)^2}$

# Appendix F – Methodology for calculating Avoided TUOS payments

## Background

Under the National Electricity Rules, Ausgrid is required to pay Avoided TUOS (ATUOS) to eligible embedded generators in Ausgrid’s electricity distribution network.

ATUOS payments recognise that energy supplied to the DNSP by the embedded generator would have otherwise been supplied from the electricity transmission network. The National Electricity Rules require that the ATUOS payable to an eligible embedded generator is calculated using a ‘with and without’ approach involving:

- Calculation of the actual TUOS charges payable by the DNSP;
- Calculation of the hypothetical TUOS charges payable by the DNSP if the Embedded Generator had not existed; and
- Payment of the full difference in the above to the embedded generator as ATUOS.

## Methodology for calculating ATUOS payment

Ausgrid’s methodology for calculating ATUOS payments is based on the maximum demand KW charge applied to the peak demand of the embedded generator (kWh) using the “with and without” methodology. Importantly, this methodology does not take into account the economic benefit provided to the rest of the electricity transmission network. For example, the peak demand of the generator may not necessarily occur at a time that causes a reduction in the overall transmission network peak demand.

## ATUOS calculation method – “with and without” method

$$ATUOS = TUOS_{withoutEG} - TUOS_{withEG}$$

where:

$$TUOS_{withoutEG} = Demand\_Tariff \times Transmission\_Peak\_Demand_{withoutEG}$$

$$TUOS_{withEG} = Demand\_Tariff \times Transmission\_Peak\_Demand_{withEG}$$

combining the above:

$$ATUOS = Demand\_Tariff \times (Transmission\_Peak\_Demand_{withoutEG} - Transmission\_Peak\_Demand_{withEG})$$

This document details the ATUOS calculation method by way of illustrative example.

## Calculation example for Avoided TUOS

Figure 1 - the 132kV network near Muswellbrook, with Hypothetical Power Station 1 receiving an ATUOS payment from Ausgrid.

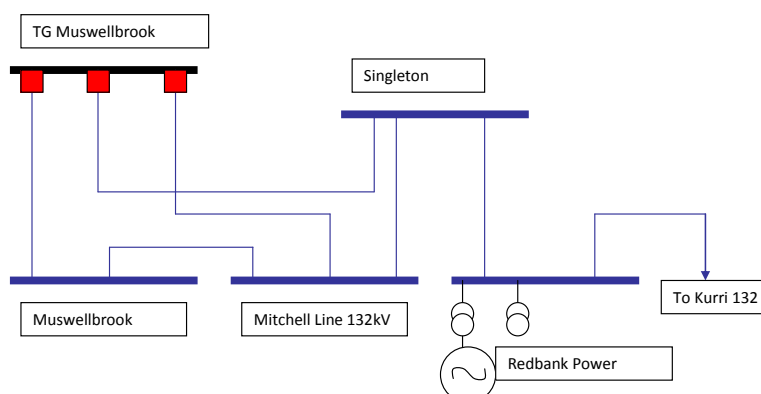



As outlined in section (i) of the Rules, the ATUOS payments are calculated on a 'with and without' basis. **The 'With case'** (ie. including actual generation at Power Station 1):

Determine the load for the TransGrid metering points at Muswellbrook. The result is labelled  $L_{With}$ , which, through Kirchoff's Current Law, 'automatically' takes into account the generation at Hypothetical Power Station 1.

Therefore we write:

$$L_{Actual} = L_{With} = L_{TransGrid} - L_{PowerStation1}$$

Now apply the TransGrid prices to the  $L_{With}$  load to determine the  $B_{With}$  TransGrid bill.

$$B_{With} = \text{Billing of } L_{With}$$

The figure below shows the 'With' case half hourly load (selected days). Demand charges for the actual TransGrid bill are based on the peak load visible on the 22<sup>nd</sup> of December (3<sup>rd</sup> daily cycle shown).

**Figure 2 – Load at Muswellbrook with generation from Power Station 1**

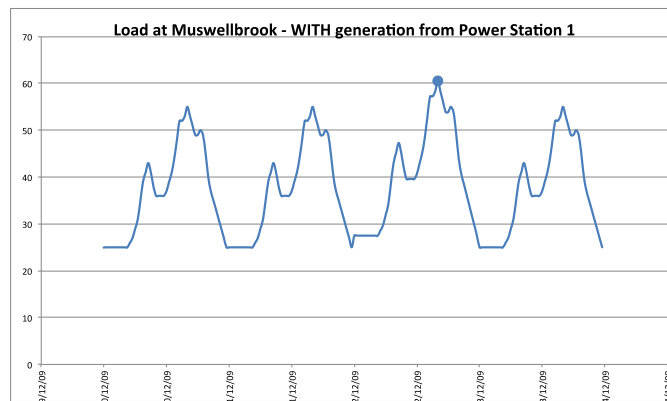

**The 'Without case'** (ie. No generation at Hypothetical Power Station 1):

Determine the load for the TransGrid metering points at Muswellbrook, had Power Station 1 not been generating. This is the sum of the metering points at TransGrid Muswellbrook and the actual generation at Hypothetical Power Station 1. This results in  $L_{Without}$  because:

$$L_{Actual} + L_{Powerstation1} = (L_{TransGrid} - L_{Powerstation1}) + L_{Powerstation1} = L_{TransGrid} = L_{Without}$$

Now apply the TransGrid prices to the  $L_{Without}$  load to determine the  $B_{Without}$  TransGrid bill.

$$B_{Without} = \text{Billing of } L_{Without}$$

The figure below shows the 'Without' case half hourly load (selected days). Demand charges for a hypothetical TransGrid bill are based on the peak load visible on the 21<sup>st</sup> of December (2<sup>nd</sup> daily cycle shown).

**Figure 3 – Load at Muswellbrook with generation from Power Station 1**

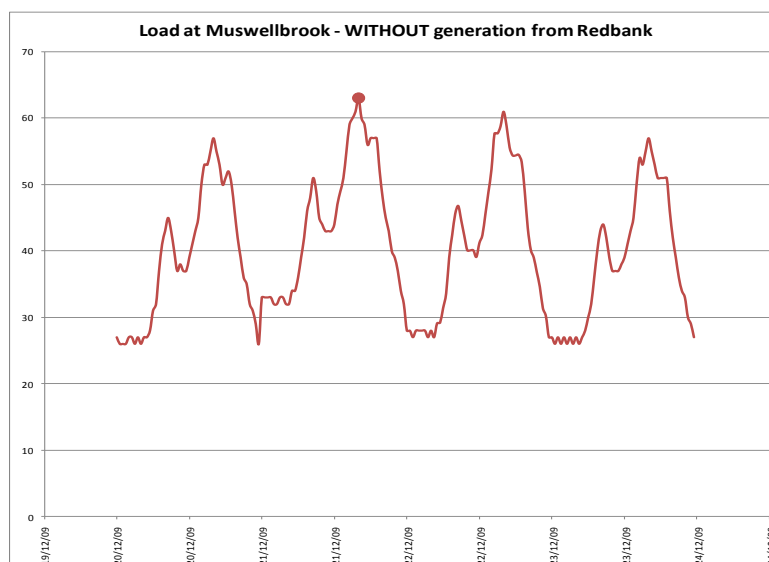

### Determining the amount payable for avoided TUOS

The amount payable by the DNSP to the embedded generator is therefore:

$$\text{ATUOS amount} = \mathbf{B}_{\text{Without}} - \mathbf{B}_{\text{With}}$$

### Metering Considerations

The load figures used in the above calculations are not necessarily net at each point. For instance:

- The TransGrid charges at Muswellbrook are based on the E register only, so the above calculations should use E only, not the (E-B) figures.
- The National Electricity Rules state describe the 'Without' case as if the Embedded Generator had 'not injected any energy' [5.5(i)(1)(i)]. Thus it is appropriate to use the pure injection volume rather than the net injection volume (B register rather than (B-E) figure). This corresponds with the viewpoint that since Power Station 1 pays network charges for its auxiliary supply (the E register), it has the right to use load when it sees fit, and must be considered separately to ATUOS considerations.

### Selection of relevant Transmission price for calculation of ATUOS payment

There are two types of locations of embedded generators within the Ausgrid's electricity network:

- Embedded generators near transmission connection points owned by TransGrid – Ausgrid in its capacity as a DNSP is directly invoiced by TransGrid for the use of these assets, so it is clearly appropriate to use the transmission charges at TransGrid owned transmission connection points for the purpose of calculating ATUOS payments for a specific embedded generator.
- Embedded generators near dual-function connection points owned by Ausgrid – Ausgrid in its capacity as a DNSP is not invoiced by TransGrid for the provision of these services. Ausgrid earns its annual revenue allowance for its dual-function assets via the setting of designated pricing proposal charges in its capacity as a DNSP. It is for this reason that Ausgrid's methodology for the calculation of ATUOS is based on the transmission charges at the TransGrid-owned transmission connection point (as opposed to the Ausgrid-owned transmission connection point) nearest to the embedded generator.

## Interaction with other Embedded Generators

In some instances, there are multiple embedded generators feeding into a transmission node. The ATUOS calculations for each site assume that all other embedded generators operate independently of the embedded generator of interest. The other embedded generators are implicitly included in the  $L_{\text{TransGrid}}$  figure by way of Kirchoff's Current Law.

## Appendix G – Daylight Saving Time

---

The time periods defined in Ausgrid's Price list and ES7 apply to local time in New South Wales. Local time is the same as Daylight Saving Time while it is in operation, and for the rest of the year, local time is the same as Eastern Standard Time.

Ausgrid's prices are structured to follow the local time, whether that is Australian Eastern Standard or Daylight Savings time.

Customers on non-Time of Use network prices are not affected by Daylight Saving Time (DST). Customers on Time of Use network prices, but without Rules compliant meters installed, have their meters programmed to adjust automatically to DST.

Where customers have joined the contestable market and have National Electricity Rules compliant metering, half hourly energy consumption data is forwarded to Ausgrid's Meter Data Provider (MDP). For the period that DST operates MDP converts the customer's energy consumption to local time for the purpose of calculating consumption in each time period. The MDP stores all data in Eastern Standard Time (EST).

### Start and End of Daylight Saving Time

The following convention is used in NSW:

*Start:* Daylight Saving Time (DST) normally begins at 2am Eastern Standard Time (EST) on the first Sunday in October. Therefore at 2am EST the clocks are put forward by one hour. The time then becomes 3am DST.

During Daylight Saving, local time in New South Wales is one hour in advance of Eastern Standard Time.

*Finish:* Daylight Saving Time normally ends at 3am DST on the first Sunday in April. Therefore at 3am DST the clocks are put back by one hour. The local time then goes in line with 2am EST.