

---

# Rapid Earth Fault Current Limiter (REFCL) Program

## LDL Zone Substation Functional Scope

Document Details	
Document Number:	REF 70-17
Version number:	1
Author:	Luke Clough
Status:	Approved
Approver:	Mike Carter
Date of approval	19/04/2018

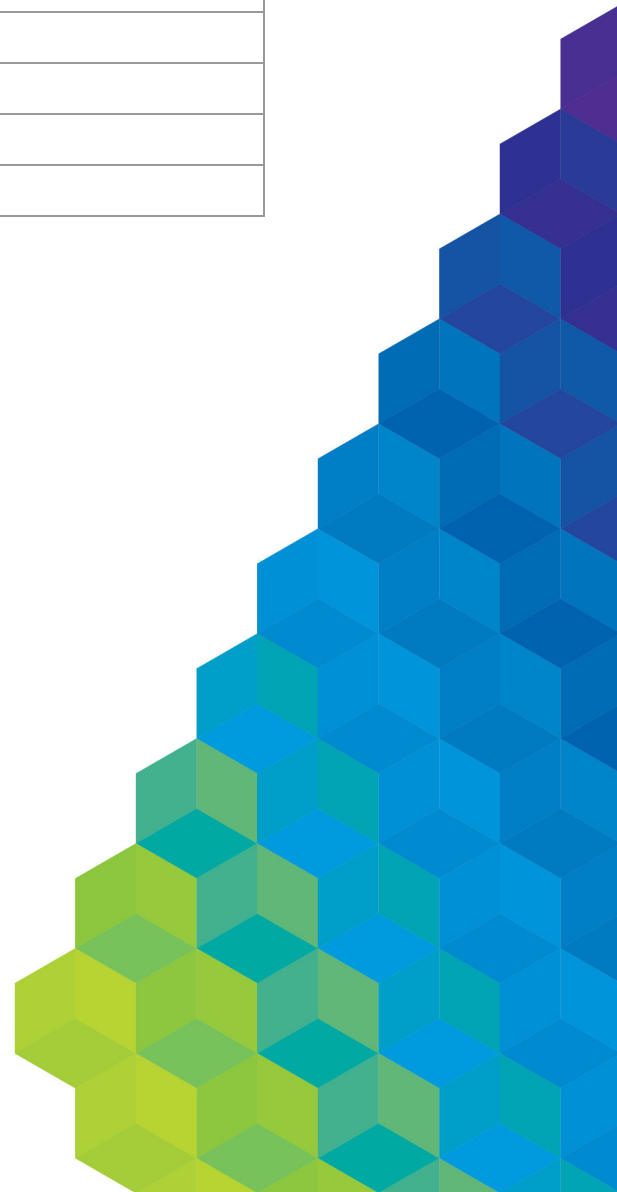

---

**LDL Zone Substation Functional Scope**

---

## REVISION HISTORY

Issue Number	Date	Description	Author
1	18 Apr 2018	First Issue	L. Clough M. Wiener H. Gupta

---

**LDL Zone Substation Functional Scope**

---

**Contents**

<b>1</b>	<b>Project overview.....</b>	<b>4</b>
1.1	Background.....	4
1.2	Selected REFCL zone substations.....	5
1.3	Lilydale zone substation overview.....	6
1.4	LDL ZSS assets.....	6
1.5	LDL ZSS single line diagram.....	7
1.6	LDL 22kV network.....	8
<b>2</b>	<b>Zone substation requirements.....</b>	<b>10</b>
2.1	Primary systems.....	10
2.2	Civil infrastructure.....	12
2.3	Secondary systems.....	13
2.4	LDL proposed single line diagram.....	15
<b>3</b>	<b>22 kV distribution feeder requirements.....</b>	<b>16</b>
3.1	Network hardening.....	16
3.2	Capacitive balancing.....	17
3.3	Compatible equipment.....	18
3.4	HV customers.....	19
<b>4</b>	<b>Proposed Site Plan.....</b>	<b>20</b>
<b>5</b>	<b>Referenced Documents.....</b>	<b>21</b>

---

## LDL Zone Substation Functional Scope

---

### 1 Project overview

This project scope covers all aspects involved in conversion of the Lilydale zone substation (LDL) from a low impedance earthed network to a resonant earthed network that can meet the performance requirements as set out in the *Electrical Safety (Bushfire Mitigation) Regulations 2013* as amended by the *Electricity Safety (Bushfire Mitigation) Amendment Regulations 2016* which came into operation on 1 May 2016.

Conversion to resonant earthing changes the electrical characteristics of the zone substation and the network it supplies. Resonant earthing significantly reduces single phase to ground fault currents. Phase to ground voltages on the faulted phase are reduced significantly whilst phase to phase voltages remain unaffected. The neutral voltage is raised to normal phase to ground voltage and the two healthy phases have their phase to ground voltages increase to phase to phase voltage levels.

Resonant earthing is only being applied to the 22 kV network. As such the resonant earthing does not affect (or protect) the following adjacent network, namely:

- 66 kV sub-transmission system;
- 12.7 kV Single Wire Earth Return System (**SWER**);
- High Voltage (**HV**) Customers with a Isolating Transformer installed; and
- Low Voltage (**LV**) supplies.

#### 1.1 Background

AusNet Services' network operates in a unique geographical location, some of which is exposed to extreme bushfire risk. These conditions warrant significant investment to mitigate the risk of bushfires as a result of earth faults on the distribution network.

The Victorian Bushfire Royal Commission, established in 2009, made several recommendations with respect to fires initiated from electricity distribution networks. Subsequently, the Victorian Government established the Powerline Bushfire Safety Taskforce (**PBST**) to investigate new cost efficient and effective technologies and operational practices to reduce catastrophic bushfire risk.

The PBST identified Rapid Earth Fault Current Limiters (**REFCLs**) installed in zone substations as an efficient and effective technology.

The *Electricity Safety (Bushfire Mitigation) Amendment Regulations 2016* (**Amended Bushfire Mitigation Regulations**) which came into operation on 1 May 2016 set out new requirements for major electricity companies including the requirement for Polyphase Electric Lines (defined as multiphase distribution between 1 kV and 22 kV) at selected zone substations to have the following abilities:

- to reduce the voltage on the faulted conductor for high impedance faults to 250 volts within 2 seconds
- to reduce the voltage on the faulted conductor for low impedance faults to
  - i. 1900 volts within 85 milliseconds; and
  - ii. 750 volts within 500 milliseconds; and
  - iii. 250 volts within 2 seconds; and
- Demonstrate during diagnostic tests for high impedance faults to limit
  - i. Fault current to 0.5 amps or less; and
  - ii. The thermal energy on the electric line to a maximum  $I^2t$  value of 0.10;

## LDL Zone Substation Functional Scope

The Amended Bushfire Mitigation Regulations define the low and high impedance faults as follows:

- High impedance = a resistance value in Ohms that is twice the nominal phase-to-ground voltage. This is equal to 25.4 k $\Omega$  or a fault current of 0.5 amps on a 22 kV network.
- Low impedance = resistance value in Ohms that is the nominal phase-to-ground network voltage divided by 31.75. This is equal to 400 Ohms or a fault current of 31.75 Amps on a 22 kV network.

### 1.2 Selected REFCL zone substations

Schedule 2 of the Amended Bushfire Mitigation Regulations lists the selected zone substations to be REFCL enabled. For AusNet Services, 22 zone substations have been selected.

Schedule 2 assigns a number of points to each of the selected zone substations. The Amended Bushfire Mitigation Regulations require AusNet Services to ensure:

- at 1 May 2019, the points set out in Schedule 2 in relation to each zone substation upgraded, when totalled, are not less than 30;
- at 1 May 2021, the points set out in Schedule 2 in relation to each zone substation upgraded, when totalled, are not less than 55; and
- on and from 1 May 2023, each polyphase electric line originating from every AusNet Services zone substation specified in Schedule 2 has the required capacity.

Our REFCL Program has been structured into three separate tranches in order to achieve the 'points' requirement by the mandated dates.

The following figure shows the specified zone substations by tranche.

**Figure 1: AusNet Services selected REFCL Zone Substations**

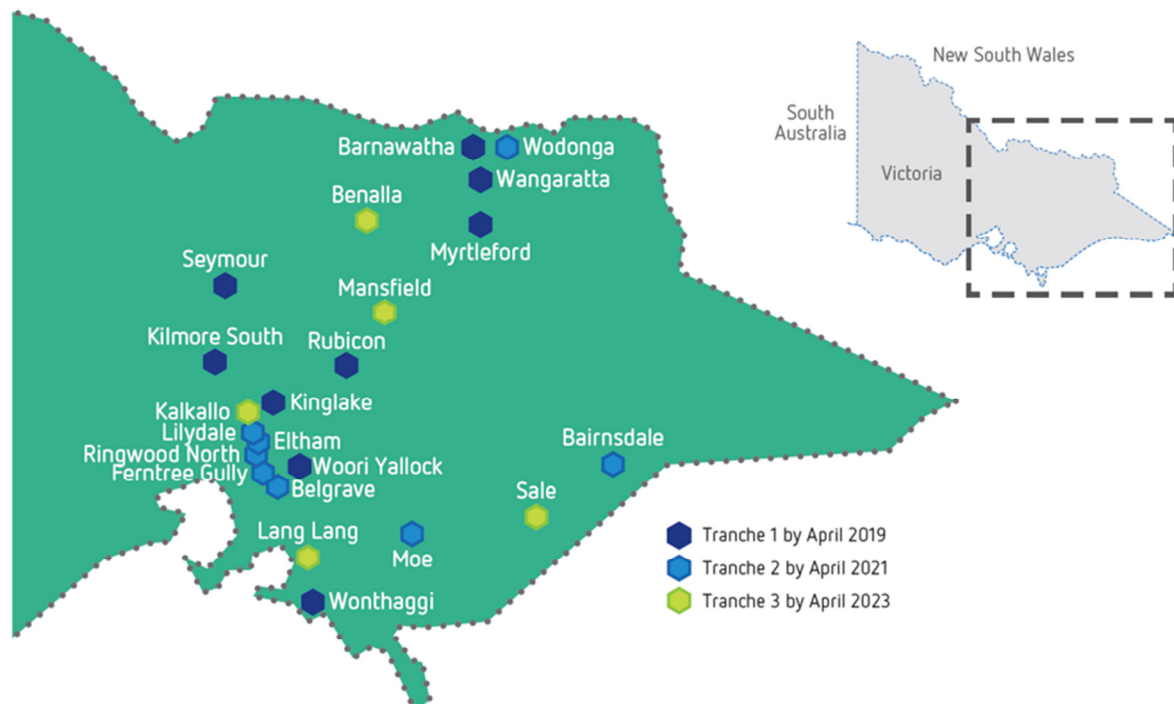

Source: AusNet Services

## LDL Zone Substation Functional Scope

### 1.3 Lilydale zone substation overview

Lilydale zone substation (**ZSS**) is included in Tranche 2 of the AusNet Services REFCL Program.

LDL ZSS is located in the suburb of Lilydale approximately 35km east of Melbourne.

Originally constructed in the late 1950s with three 10/13 MVA transformers, there are now three 20/33 MVA transformers, the original transformers progressively replaced since 2002. The original outdoor 22 kV switchyard was replaced with an indoor switchboard in 1999.

The Lilydale electricity distribution area includes both residential and commercial suburban areas around Lilydale as well as peri-urban areas that are heavily tree-covered, steep and have limited access between the suburbs and townships Mooroolbark, Mt Evelyn, Yarra Glen Healesville and Silvan.

#### 1.3.1 Key issues and challenges

The LDL ZSS is an outdoor switchyard with limited space for the installation of primary equipment to support the conversion to resonant earthing.

The existing site control room is completely full and cannot support the transition to REFCL. Refer to section 2.2.3 of this functional scope document for an overview of the site control room options analysis.

The size of the LDL network exceeds the size that will reliably achieve the legislated performance requirements of the REFLC installations. To achieve the required performance the 22 kV network must be split on Total Fire Ban (TFB) days running on 2 separate REFCLs.

### 1.4 LDL ZSS assets

The following table provides an overview of the current assets located at the LDL ZSS.

**Table 1: LDL Zone Substation – current assets**

Zone Substation	Details
Location	In the the suburb of Lilydale, 35km east of Melbourne
Established	Late 1950s
Supply Area	Lilydale, Montrose, Yarra Glen, Mt Evelyn, Coldstream and Chirnside Park.
Customers	21,911
Zone Substation transformers	3 x 33MVA 66/22 kV
22 kV Buses	2
Capacitor Banks	CAP Bank 1: 2 x 6 MVar (Stepped) CAP Bank 2: 1 x 5 MVar
Feeders	8
Station services transformers	2 x 50 kVA 22/0.415 V
Schedule 2 points allocation	3

Source: AusNet Services

**LDL Zone Substation Functional Scope**

**1.5 LDL ZSS single line diagram**

The following figure represents the current single line diagram of the LDL ZSS.

**Figure 2: LDL Current Single Line Diagram**

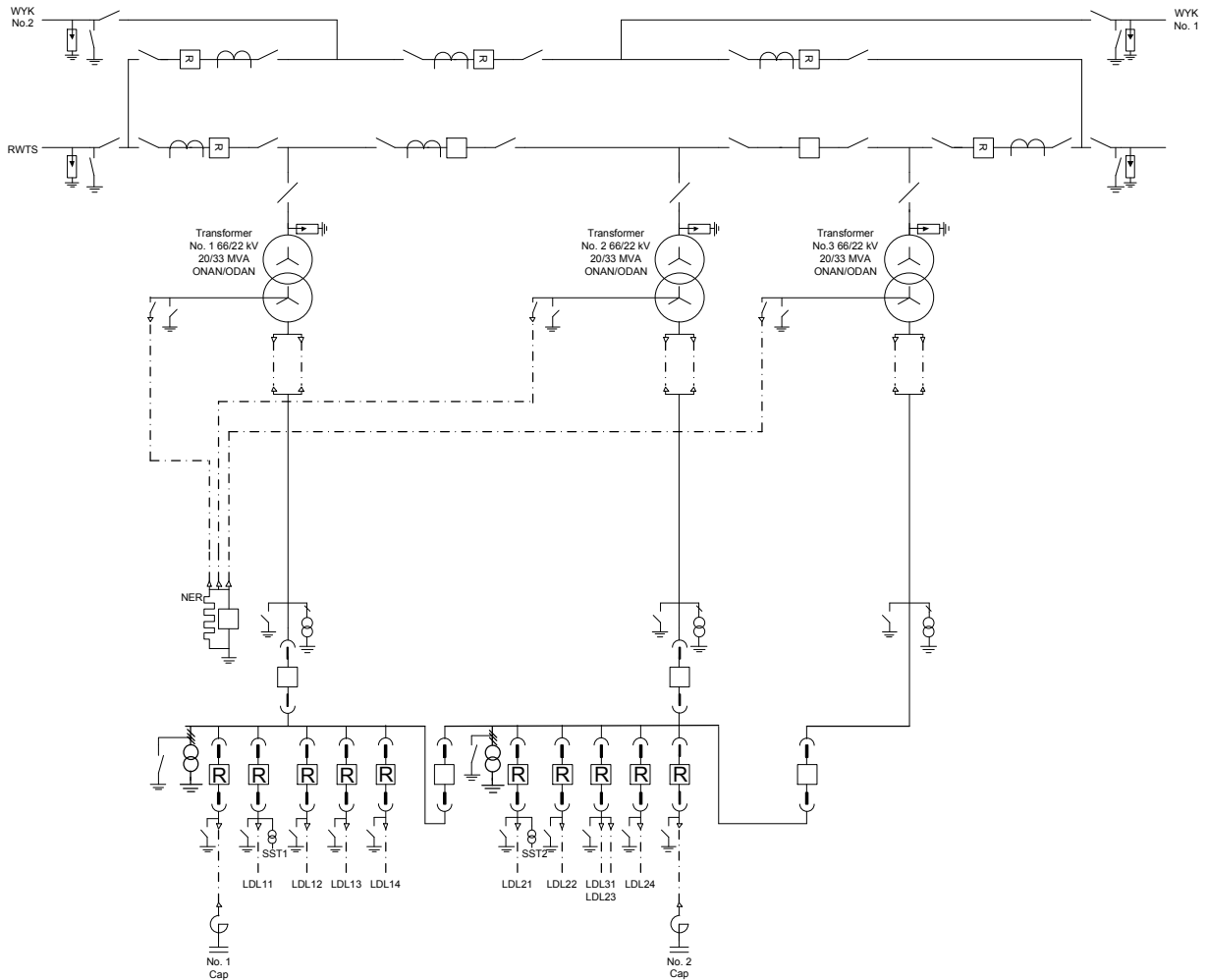

Source: AusNet Services

---

**LDL Zone Substation Functional Scope**

---

**1.6 LDL 22kV network**

The following table provides an overview of the 22kV network originating from the LDL ZSS.

**Table 2: LDL 22kV Network – current configuration**

Network	Details
Total Network Length (km) <sup>1</sup>	616.2
Aerial Bundled Cable ( <b>ABC</b> ) Length (km)	7.2
Underground ( <b>U/G</b> ) 3 phase ( <b>ph</b> ) Cable Length (km)	45.2
U/G 1ph Cable Length (km)	0.0
Overhead 3ph Line Length (km)	326.7
Overhead 1ph Line Length (km)	104.3
Estimated network capacitance (Amps ( <b>A</b> ))	187 (244 including all transfer feeders)
HV Customer Connections	4 (7 Including all transfer feeders)
Automatic Circuit Reclosers ( <b>ACRs</b> )	6
Sectionalisers	36
HV Regulator sites	1
Surge Arrestor Sites	1752

Source: AusNet Services

---

<sup>1</sup> Not including SWER or Transfer feeders



### LDL Zone Substation Functional Scope

The following figure shows an aerial view of the 22kV feeders originating from the LDL ZSS.

**Figure 2: LDL 22kV feeders shown in blue**

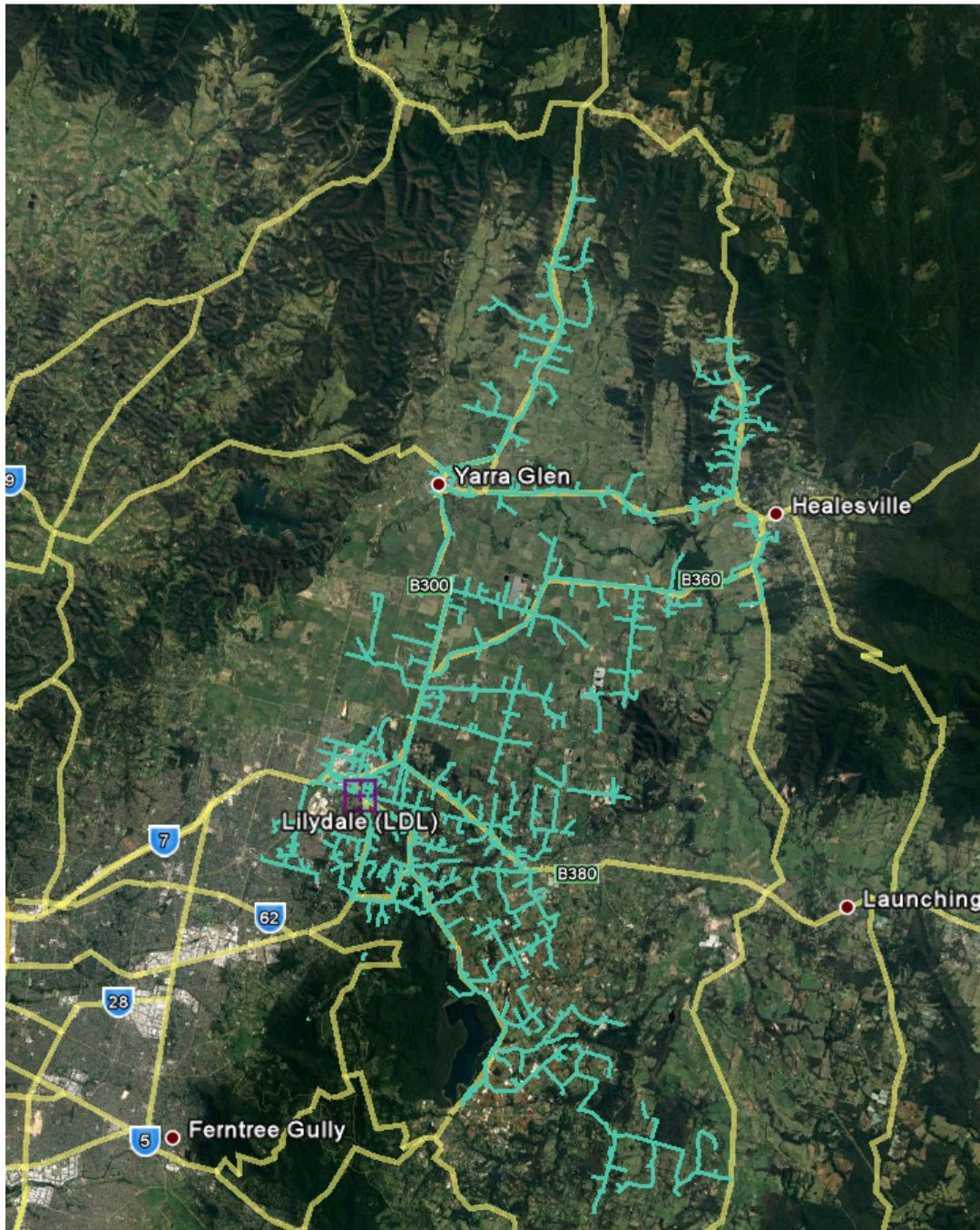

Source: AusNet Services

---

## LDL Zone Substation Functional Scope

---

## 2 Zone substation requirements

The successful implementation of resonant earthing requires a number of changes at the zone substation including the installation of the resonant earthing equipment, installation of supporting infrastructure and replacement of equipment that cannot handle the elevated voltages introduced by the transition from low impedance to resonant earthing.

The scope of works for the installation of REFCL equipment, supporting infrastructure and asset hardening at the LDL ZSS is summarised in the following sections of this functional scope document.

### 2.1 Primary systems

#### 2.1.1 REFCL Equipment

Taking into account the network size, dissymmetry and damping originating from the LDL ZSS, two (2) Arc Suppression Coils (**ASC**) are required to be installed at LDL ZSS.<sup>2</sup>

- Installation of Ground Fault Neutraliser (**GFN**) primary equipment, namely:
  - 2 ASC;
  - 2 Residual Current Compensator Inverter (**RCC**); and
  - 2 Grid Balancing Unit.

#### 2.1.2 Neutral Bus

A neutral bus system must be installed to control of the neutral earthing arrangements allowing change of operational mode during fault management.<sup>3</sup>

The Neutral Bus System comprises:

- Installation of 2 Neutral Buses. Each Neutral bus includes a Neutral Voltage Transformer.
- Installation of 3 Surge Arrestors on each transformer neutral.
- Installation of the following single core 185 sq mm 22 kV neutral cables:
  - No. 1 Transformer to No. 1 Neutral Bus;
  - No. 2 Transformer to No. 2 Neutral Bus;
  - No. 1 Neutral Bus to No. 2 Neutral Bus(common No. 2 Transformer connection);
  - No. 3 Transformer to No. 2 Neutral Bus;
  - No. 1 Neutral Bus to No. 1 ASC;
  - No. 1 Neutral Bus to NER;
  - No. 1 Neutral Bus to No. 2 Neutral Bus (common NER connection); and
  - No. 2 Neutral Bus to No. 2 ASC;

#### 2.1.3 Station Service Transformers

The existing 50 kVA Station Service 22/0.415 kV transformers do not have adequate rating to supply the RCC during fault compensation and must be replaced with suitably rated transformers.

---

<sup>2</sup> For further information on the ARC sizing refer to REF 30-04 REFCL Program Arc Suppression Coil Sizing Policy

<sup>3</sup> For further information on the Neutral Bus refer to REF 20-17 REFCL Program Operating Modes

---

## LDL Zone Substation Functional Scope

---

- Installation of 2 750 kVA 22/0.415V transformers;
- Removal of existing 2 50 KVA Station Service Transformers; and
- Re-use of existing connection points, review fuse rating and replace with appropriate rated fuses.

### 2.1.4 AC Supplies

The existing AC supply boards cannot supply the current required by the RCC.

- Installation of 1 AC 415V REFCL change over board rated for 1250A to supply the REFCL equipment.
- Installation of 1 AC 415V station services change over board rated for 160A to supply the station AC supplies.

### 2.1.5 Surge Arrestors

The existing surge arrestors are a mixture of units made by Bowthorpe, ABB, Siemens and Cooper. None of these units are suitable for operation with the voltages imposed by REFCL operations.

- Replace 7 sets of 22 kV Surge Arrestor sets within the zone substation. Reuse of existing structures.

The transformer neutral will also require a surge arrestor to be installed due to various scenarios leading to excessive overvoltage at the neutral point.

### 2.1.6 Instrument Transformers

#### Voltage Transformers (VTs)

The existing 22 kV transformer VTs are not rated for the voltages imposed by REFCL operations and must be replaced.

- Installation of 3 new No. 1 Transformer Voltage Transformers on existing structures and retirement of existing units.
- Installation of 3 new No. 2 Transformer Voltage Transformers on existing structures and retirement of existing units.
- Installation of 3 new No. 3 Transformer Voltage Transformers on existing structures and retirement of existing units.

#### Current Transformers (CTs)

The existing CTs are considered acceptable for REFCL voltages.

#### Zero Sequence CTs

Zero Sequence (Core Balance) CTs are required to measure the individual imbalance on each feeder and any change in balance due to network modification or switching.

- Installation of a zero sequence CT on each feeder exit, 8 CTs to be installed in total. CTs are to be mounted in the cable termination compartments of the switchboard.

### 2.1.7 22 kV Cabling

22 kV transformer and feeder exit cables are critical assets within the substation. Failures in service may result in significant customer outages. To minimise this likelihood of failure, offline cable testing is to be undertaken and any issues identified are to be addressed.

If the testing identifies any issues, it is likely to result in full cable replacements due to the short lengths of these cables.

Offline partial discharge and high potential tests to occur on the following cables:

- No. 1 Transformer 22 kV cables;

---

## LDL Zone Substation Functional Scope

---

- No. 2 Transformer 22 kV cables;
- No. 3 Transformer 22 kV cables;
- LDL11 Feeder exit cable;
- LDL12 Feeder exit cable;
- LDL13 Feeder exit cable;
- LDL14 Feeder exit cable;
- LDL21 Feeder exit cable;
- LDL22 Feeder exit cable;
- LDL23 Feeder exit cable;
- LDL24 Feeder exit cable;
- LDL31 Feeder exit cable;
- No. 1 Capacitor Bank cable; and
- No. 3 Capacitor Bank cable.

### 2.1.8 Capacitor Banks

The existing No. 1 Capacitor Bank is a 2 x 6.0 MVA grounded star arrangement. The existing Capacitor Bank will be replaced to achieve an ungrounded star arrangement.

- Installation of the No. 1 Capacitor bank earthing arrangements and revision of the current transformers to suit the revised earthing. Assessment of capacitor cans for suitability with the revised voltage profile.

The existing No. 2 Capacitor Bank is a 1 x 5.0 MVA grounded star arrangement. The existing Capacitor Bank will be replaced to achieve an ungrounded star arrangement.

- Installation of the No. 1 Capacitor bank earthing arrangements and revision of the current transformers to suit the revised earthing. Assessment of capacitor cans for suitability with the revised voltage profile.

### 2.1.9 Earth Grid Design

The existing earth grid design shall be reviewed to ensure the earthing system will continue to adequately protect personnel, plant and the public post the introduction of resonant earthing.

## 2.2 Civil infrastructure

A number of civil infrastructure installations and modifications are required to support the REFCL installation.

### 2.2.1 Station Service Transformer

- Installation of two (2) concrete foundation pads, cable conduits and oil bunds.

### 2.2.2 ASC

- Installation of two (2) concrete foundation pads, neutral cable conduits and oil bunds.

### 2.2.3 Neutral Bus

- Installation of a two (2) concrete foundation pads and conduits for neutral and control cables.

### 2.2.4 REFCL control room

The existing site control room at the LDL ZSS is completely full and does not have the physical space for the required installation of REFCL technology, namely the RCC unit, REFCL control panels, protection and communications updates and modifications and network monitoring and switchgear interface relays. It also cannot accommodate the modifications required to the existing protection, control and communications equipment.

Options considered included:

- Do nothing



---

## LDL Zone Substation Functional Scope

---

- Installation of two(2) new standard REFCL control rooms
- Installation of one(1) large control room.

The do nothing option does not allow the installation of REFCL technology at LDL and therefore does not meet the requirements of the regulations. Installation of two standard REFCL control rooms meets the two GFN needs of the LDL station however will still not accommodate the modifications required to the existing protection, control and communications equipment.

The chosen option is therefore to install a single large control room. The following civil items are required to deliver this option.

- Installation of a concrete foundation pad for REFCL control room.
- Installation of a standard transportable REFCL control room to house the RCC, grid balancing unit and GFN control and monitoring systems.

### 2.2.5 Cap Bank

- Installation of two (2) concrete foundation pads and cable conduits.

### 2.2.6 Cable trench

- Installation of additional cable trenches for connection from the existing cable trench system to the following locations:
  - REFCL control room;
  - ASC; and
  - Neutral Bus.

### 2.2.7 Earth Grid

- Extension of the earth grid to protect the REFCL control room, ASCs and Neutral Buses.

### 2.2.8 Switchyard Surfacing

- Restoration of the disturbed switchyard surfaces.

## 2.3 Secondary systems

A number of secondary systems need to be added or modified to support the installation of REFCL equipment at the station.

### 2.3.1 GFN Control System

The GFN product includes a control panel containing the master and slave control modules, HMI computer, VT and CT inputs and trip outputs and ASC and RCC interfaces.

Additionally the GFN vendor will install a free issued C30 relay and a RUGGEDCOM Ethernet switch to allow AusNet Services control the operational mode of the GFN system.

- Installation of 2 GFN control system panels as part of the GFN product; and
- C30 relays and RUGGEDCOM RSG2488 Ethernet Switches (1 per GFN) shall be free issued for installation in their GFN control system panels.

### 2.3.2 Neutral Control System

- Installation of 1 neutral bus interface control system panel including:
  - No. 1 Neutral Bus X ABB REF630 controller relay;
  - No. 1 Neutral Bus Y GE C30 controller relay;
  - No. 2 Neutral Bus X ABB REF630 controller relay; *and*
  - No. 2 Neutral Bus Y GE C30 controller relay.

---

## LDL Zone Substation Functional Scope

---

### 2.3.3 Fault Recording and Switchgear Interface Panels

Fault location and diagnosis can be significantly more difficult with resonant earthed networks.

To assist with GFN commissioning, annual compliance testing and fault investigation activities, additional network monitoring relays must be installed to capture bus voltage, neutral voltage and bus current waveforms.

To interface status and control signal wiring between the switchgear and the GFN system, one control relays are required per 22 kV bus.

- Installation of 2 network monitoring and switchgear interface panels. Each panel includes:
  - 2 x ELSPEC Network Monitoring relays; and
  - 1 x C30 control relays.

### 2.3.4 DC System

- 125V DC distribution panel needs to be installed for new control room.

### 2.3.5 Protection Systems

#### Feeder Protection

The existing 8 ABB REF630 feeder protection relays are suitable for operation with the GFN but will require a firmware upgrade.

#### Transformer Voltage Regulation

The existing voltage regulation scheme is not compatible with station split bus operation.

- Install standard transformer voltage control and regulation panel

#### Bus Protection

The existing 22kV X bus protection is not able to provide the back-up voltage protection functions required for GFN installations.

- Install 2 high impedance bus protection systems based on REF630 relays.

#### Station Master Earth Fault (MEF)

The existing ABB REF630 MEF protection relay is suitable for operation with the GFN but will require a firmware upgrade.

#### Station Backup Earth Fault (BUEF)

The existing GE F35 BUEF protection relay is suitable for operation with the GFN but will require a firmware upgrade.

#### Capacitor bank protection and control

The existing capacitor bank protection and control scheme will be modified to suit the revised earthing arrangement and CT inputs.

### 2.3.6 Communications

The new equipment in the REFCL control room requires connection to the existing Digital Interface Cubicle (DIC).

- Installation of Fibre Termination Equipment (FTE) in the existing DIC panel;
- Installation of FTE in the REFCL Control Room; and
- Installation of communications cabling between DIC and REFCL control equipment in the new REFCL control room.

LDL Zone Substation Functional Scope

2.4 LDL proposed single line diagram

The following figure represents the proposed single line diagram of the LDL ZSS following the installation of the GFN and associated compatible equipment.

Figure 3: LDL proposed single line diagram

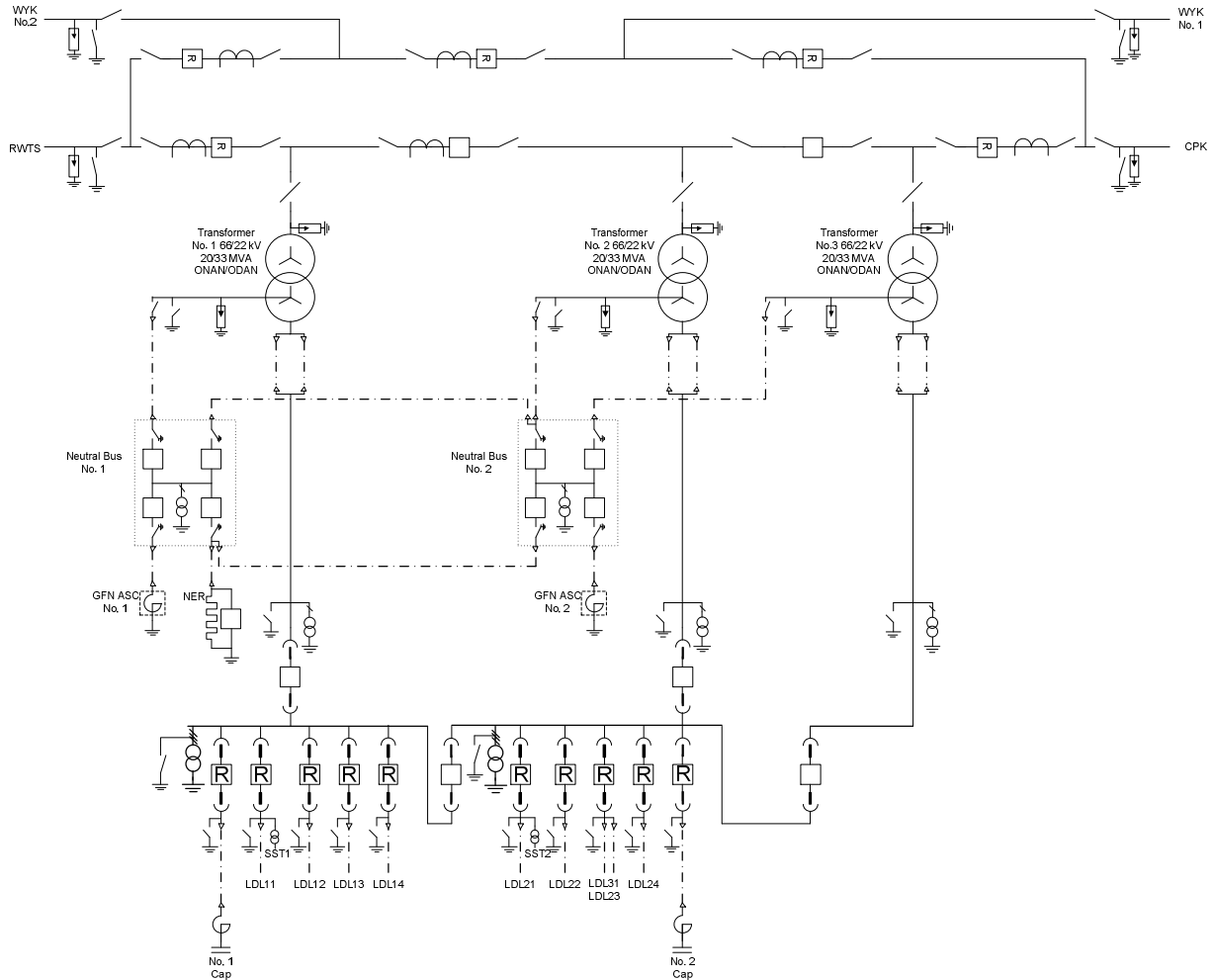

Source: AusNet Services

## LDL Zone Substation Functional Scope

### 3 22 kV distribution feeder requirements

The suitability of the assets on the feeders supplied by a REFCL equipped zone substation is critical to ensure successful operation of the technology without undue reliability or safety consequences.

These assets must be able to sustain the additional phase to ground voltage stress introduced by the REFCL technology. Each feeder must be balanced, meaning that each phases' capacitance is equal. This ensures the REFCL technology works at the regulated performance levels and operates normally during REFCL fault compensation.

To achieve these outcomes, three programs address equipment that does not meet the above criteria, namely:

- Network hardening;
- Capacitive balancing; and
- Equipment compatibility evaluation.

Additionally, customers connected directly to the 22 kV supply network need to ensure their electricity assets can withstand REFCL voltages. If the HV customer assets are not hardened to withstand REFCL voltages, they must be isolated from the REFCL protected network.

#### 3.1 Network hardening

Operation of resonant earthing, on which the REFCL technology is based, introduces periods of increased phase to ground voltages.

This increased voltage can cause issues for existing assets specified for a solidly or low impedance earthed operational profile.

AusNet Services has assessed its assets and determined that network assets most impacted by the increased voltages are:

- Surge arrestors; and
- HV cables.

##### 3.1.1 Surge arrestors

Surge arrestors are a voltage dependent resistor designed to begin to conduct as the voltage increases to suppress very short duration overvoltage such as those associated with lightning strikes. In doing this, they absorb energy whilst the voltage is higher. If not rated suitably, surge arrestors may overheat and fail during REFCL operation, potentially obstructing the effectiveness of the REFCL in limiting the fault current.

AusNet Services has tested each type of surge arrester installed on its networks to determine the suitability of each type for REFCL protected networks.<sup>4</sup> To determine the volumes for the LDL network AusNet Services has inspected each surge arrester site and confirmed the surge arrester types installed to determine replacement requirements.

At LDL approximately 13% of surge arrester sites need to be addressed.

**Table 3: LDL surge arrester replacement volumes**

	Sites	Units
	224	535

<sup>4</sup> For further information refer to REF 20-07 REFCL Program Line Hardening Strategy.



## LDL Zone Substation Functional Scope

Source: AusNet Services

### 3.1.2 HV Cables

Insulated HV cables are susceptible to failure resulting from damage that can occur during operation at higher voltages. Periods of operation at higher voltage can cause immediate failure or initiate partial discharge that can continue to damage the cable after voltages have returned to normal. Premature cable failure can occur in the subsequent hours or days after the initiating overvoltage occurred.<sup>5</sup>

LDL has a significant volume of cables that will require a testing and replacement program to ensure the ongoing reliable service to the network. To determine the testing, repairs and replacement volumes for the LDL network AusNet Services has reviewed its network cable data and modelled likely volumes and rectifications based upon the learnings from testing results at Tranche 1 sites<sup>6</sup>.

**Table 4: LDL HV cable testing and replacement volumes**

PryCAM tests	Offline tests	Cable System Repairs	Replaced cable
146	42	17	Estimated 2,333m

Source: AusNet Services

### 3.1.3 Other Assets

Other asset classes may exhibit issues with the voltages introduced by operation of REFCL technology including:

- Distribution transformers; and
- Line insulators.

At this time, there is not enough experience from REFCL testing and operation at the Woori Yallock (WYK) ZSS to demonstrate a need to replace these assets.

## 3.2 Capacitive balancing

Capacitive balance is a key enabler of achieving the performance requirements of the Amended Bushfire Mitigation Regulations. Neutral voltage caused by capacitive imbalance decreases the sensitivity of the REFCL technology.<sup>7</sup>

A number of balancing activities are required to achieve the necessary capacitive balance level including:

- Installation of a 3<sup>rd</sup> conductor on single phase spurs where only a few spans are required;
- Conversion of single phase cable spurs to three (3) phase by connecting the 3<sup>rd</sup> phase;
- Phase rotations of single phase spurs;
- Installation of single phase capacitor banks at the beginning of single phase spurs;
- Installation of 3 phase capacitor banks for each automatically switchable section; and
- Removal of fuses on network segments with excessive charging current.

<sup>5</sup> For further information refer to REF 20-07 REFCL Program Line Hardening Strategy

<sup>6</sup> For further information refer to REF 20-07 REFCL Program Line Hardening Strategy

<sup>7</sup> For further information refer to REF 20-06 REFCL Program Network Balancing Strategy

## LDL Zone Substation Functional Scope

Whilst the LDL network is relatively short, it has a high number of automatic switching sections to provide reliability in the heavily tree covered areas it serves.

This necessitates an increased quantum of balancing activities for the relatively short network compared to longer, less automated, networks. Network data has been analysed to identify the material sources of imbalance and the optimal mixture of balancing works to achieve the necessary level of capacitive balance for the LDL network.

**Table 5: LDL network capacitive balancing volumes**

Spans of 3 <sup>rd</sup> phase	Unbonded 3 <sup>rd</sup> phase (cable)	Single phase spur phase rotations	Single phase balancing capacitors	Three phase balancing capacitors	Fuse links
10	5	8	2	10	15

Source: AusNet Services

Furthermore, the feeders originating out of the zone substation may also be reconfigured such that feeder capacitances and loads are balanced at a bus level to optimise REFCL performance.

### 3.3 Compatible equipment

Some existing network equipment is incompatible with the operation of REFCL technology. This equipment includes:

- Automatic Circuit Reclosers (**ACRs**);
- Sectionalisers; and
- HV voltage regulators.

#### 3.3.1 ACRs

Existing ACRs have non-directional fault detection and may 'mal' operate during REFCL operation due to the capacitive charge flowing back through healthy parts of the network to the fault.

Replacement ACRs have VTs installed to determine when the REFCL is displacing the neutral voltage and suppress tripping for reverse fault current direction.<sup>8</sup>

Existing ACRs require upgrades or replacement to operate successfully with REFCL technology.

At LDL there are a high number of automatic switchable sections involving ACRs to ensure a reliable service for the customers served.

Each ACR on the LDL network has been identified from network data and its type confirmed through protection setting data to determine whether it can be upgraded or must be replaced.

**Table 6: LDL ACR upgrade and replacement volumes**

Upgrade	Replacement
7	3

Source: AusNet Services

<sup>8</sup> For further information refer to REF 20-08 REFCL Program Automatic Circuit Recloser Strategy

## LDL Zone Substation Functional Scope

### 3.3.2 Sectionalisers

Existing sectionalisers, that are a key part of AusNet Service's Distribution Feeder Automation to provide customer reliability benefits, do not have high accuracy CTs that are compatible with the low fault currents that the REFCL introduces.<sup>9</sup>

Existing sectionalisers require replacement to operate successfully with REFCL technology.

At LDL there are a high number of automatic switchable sections involving sectionalisers, despite the relatively short network, to ensure a reliable service for the customers served. Each sectionaliser on the LDL network has been identified from network data and individually confirmed as non-compliant with REFCL requirements.

**Table 7: LDL Sectionaliser update and replacement volumes**

Upgrade	Replacement
0	44

Source: AusNet Services

### 3.3.3 HV voltage regulators

Some HV voltage regulators have individual phase voltage tap controls. These controllers are not compatible with REFCL operation as they may try to tap voltages whilst the REFCL is compensating and introduce further imbalance reducing the effectiveness of the REFCL.<sup>10</sup>

The LDL network has no HV voltage regulators.

## 3.4 HV customers

HV customers are connected directly to the 22 kV network rather than the LV networks and are therefore impacted by the increased voltages introduced by the REFCL technology. This can cause issues for customers including:

- requirements to harden their equipment to withstand the increased voltages;
- updates to protection equipment and settings; and
- interruption to the customer's business operation.

In some cases, it may be more economical to isolate the customer from the REFCL voltage profiles rather than address each of the issues listed above.

To determine the most appropriate solution for each impacted HV customer AusNet Services has, via a dedicated HV Customer Lead, engaged with the HV customer to understand the nature of their HV connection assets and operations in order to identify the most appropriate solution.

### 3.4.1 HV customers serviced by the LDL network

There are five (5) HV customers served by the LDL network. AusNet Services anticipates that all 5 sites will be isolated from REFCL to comply with the requirements for REFCL operational voltages.

<sup>9</sup> For further information refer to REF 20-13 REFCL Program Distribution Feeder Automation (DFA) Strategy

<sup>10</sup> For further information refer to REF 20-09 REFCL Program Voltage Regulator Strategy

## LDL Zone Substation Functional Scope

### 4 Proposed Site Plan

The following figures provides an aerial view of the current LDL ZSS with the proposed sites of the new REFCL-related assets and control room.

**Figure 5: Aerial view of the LDL ZSS**

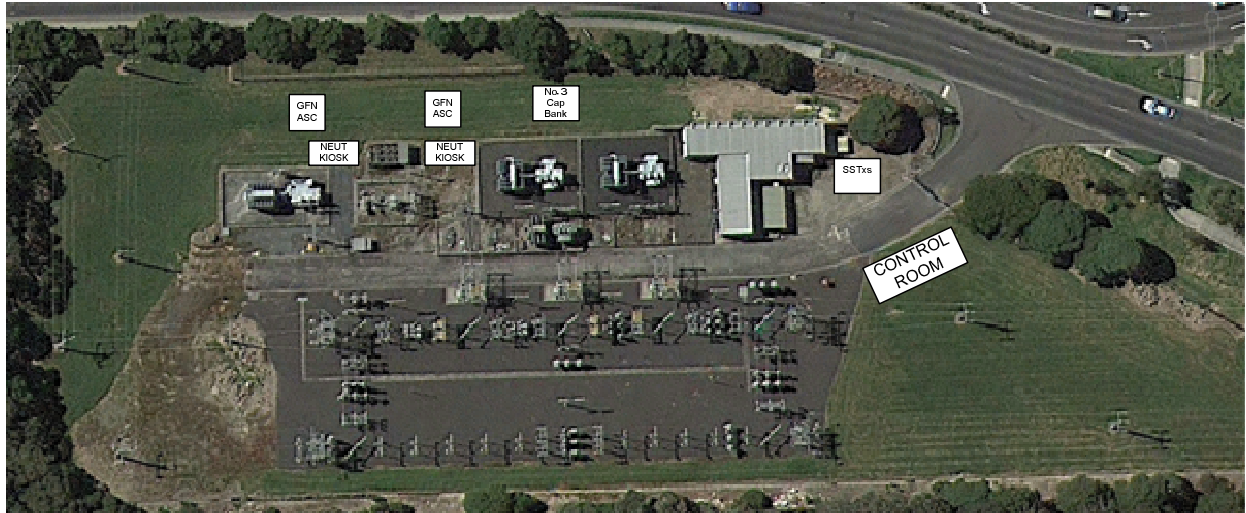

Source: AusNet Services

---

**LDL Zone Substation Functional Scope**

---

## 5 Referenced Documents

Supporting documents referenced in this document:

- REF 20-06 REFCL Program Network Balancing Strategy
- REF 20-07 REFCL Program Line Hardening Strategy
- REF 20-08 REFCL Program Automatic Circuit Recloser Strategy
- REF 20-09 REFCL Program Voltage Regulator Strategy
- REF 20-13 REFCL Program Distribution Feeder Automation Strategy
- REF 20-17 REFCL Program Operating Modes
- REF 30-04 REFCL Program Arc Suppression Coil Sizing Policy
- REF 30-10 REFCL Program HV Customer Policy