

AURORA ENERGY

DISTRIBUTION LOSS FACTOR CALCULATION METHODOLOGY

JULY 2004

A. Baitch
BES (Aust) Pty Ltd
25 August 2004

Report 4246/3



TABLE OF CONTENTS

1	INTRODUCTION.....	3
2	DEFINITIONS.....	3
3	SYSTEM LOSSES.....	4
3.1	Power and Energy Losses	4
3.2	Load factor and loss load factor	4
3.2.1	Series power losses.....	4
3.2.2	Shunt power losses	6
3.2.3	Total power losses.....	6
3.3	Application of Distribution Loss Factors.....	6
4	CODE REQUIREMENT ON DISTRIBUTION LOSSES	9
5	AVERAGE DLF	13
6	SITE SPECIFIC DLF FOR QUALIFIED END USERS.....	14
7	ALLOCATION OF 'TOP DOWN LOSSES' UTILISING THE CALCULATED 'BOTTOM UP TECHNICAL LOSSES'.....	15
8	FORWARD-LOOKING DISTRIBUTION LOSS FACTORS	16
9	TRANSMISSION LOSS FACTORS.....	17
10	CONCLUSION.....	18
11	APPENDIX A.....	19
11.1	INTRODUCTION.....	19
11.2	SUB-TRANSMISSION LINE LOSSES	22
11.3	ZONE SUBSTATION LOSSES	23
11.4	HIGH VOLTAGE DISTRIBUTION LINE LOSSES	24
11.5	DISTRIBUTION SUBSTATION LOSSES	25
11.6	LOW VOLTAGE LOSSES.....	26
11.7	DLF CALCULATION AND APPLICATION RULES.....	27
12	APPENDIX B.....	28
13	APPENDIX C.....	33

1 INTRODUCTION

This report examines the issues associated with computation of distribution loss factors in Tasmania. The aim of this report is to consider methodology associated with the computation and application of distribution loss factors (DLFs) in the electricity network in Tasmania.

2 DEFINITIONS

Aurora	Aurora Energy Pty Ltd -Tasmania's electricity distribution and retail company.
Transend	Transend Networks Pty Ltd - owns and operates the electricity transmission system in Tasmania
Point of Purchase	Physical point at which Aurora purchases its electricity from Transend
High Voltage	System voltages 66kV and above and below 330 kV
Medium Voltage	System voltages above 1kV and below 66kV
Low Voltage	System voltages less than 1kV
Load Factor	Ratio of average demand over maximum demand
Load Loss Factor	Ratio of average power loss over power loss at maximum demand
DLF	Distribution Loss Factor
A_{L-n}	Annual losses in Customer Category n
S_{L-n}	Sales in Customer Category n

3 SYSTEM LOSSES

3.1 Power and Energy Losses

Power system losses are the difference in the amount of energy or power that is required to be delivered to a system to supply the customer's energy or power needs.

- 1) Power losses, defined in kW or MW create a need for the provision of additional capacity to be installed on the system over and above that required to meet the system demand
- 2) Energy Losses, defined in kWh or MWh, is the integral of the power losses with respect to time and represents the amount of additional energy that needs to be purchased at the point of purchase by Aurora to supply the customer demand for the corresponding period.

Energy losses associated with a distribution system can be classified as follows:

- 1) Technical Losses - losses associated with the the electrical system
 - a) Series losses which are proportional to the square of the current and to the resistance of the circuit elements and
 - b) Shunt losses due the excitation losses in transformers and rotating machines, as well as leakage currents in cables
- 2) Non-technical losses - losses associated with unidentified and uncollected revenue. This covers matters such as illegal connections, meter tampering, metering errors, errors in estimating unmetered supplies, errors in invoicing and revenue collection.

Total power in a system is the vector sum of real and reactive power. Losses on the system are generally considered in terms of the real power and energy components and are measured in kW and kWh respectively. With respect to reactive power losses on a system (kVAr and kVArh), although the area of reactive power is a signiifant issue for distribution network service providers it is not a parameter that is easily measured and does not form part of the normal revenue basis. Accordingly, it is not considered further in this report.

3.2 Load factor and loss load factor

3.2.1 Series power losses

Losses in series elements are related to the square of the current flow. It is possible to establish a relationship between between peak demand on a system and the average technical losses through consideration of load factors and loss load factors.

Load Factor (LF) is defined as the ratio of the average demand over a period of time to the maximum demand within that period for the particular network

Loss Load Factor (LLF) is defined as average power losses over a period of time to the losses at the time of peak demand.

Where demand recordings exist, such as 15 minute readings (or half hour readings), the LF and LLF can be expressed as follows:

LF = Sum of 15 min demands / (maximum demand * number of 15min periods)

LLF = Sum of squares of 15min demands / (square of maximum demand * number of 15min periods)

or expressed in mathematical terms for a one year period.

$$LF = \sum_{15min}^{1year} \frac{15MinEnergyForYear}{MaximumDemand * Numberof15MinPeriodsforYear}$$

$$LLF = \sum_{15min}^{1year} \frac{(15MinEnergyForYear)^2}{MaximumDemand^2 * Numberof15MinPeriodsforYear}$$

Where 15 minute demand recordings are not available, empirical formulae are available that can be used to estimate the LLF from an LF.

$$LLF = k * LF + (1 - k) * LF^2$$

where k = a constant, typically 0.1, 0.2 or 0.3

Typically = 0.3 for subtransmission systems

= 0.2 for medium voltage feeders and distribution substations

= Sample sections of the network can be analysed to produce an estimate of the k factor applicable for the rest of the system

$$LF = P_{ave} / P_{max}$$

where P_{ave} = average demand over a period (say 1 year)

P_{max} = maximum demand over a period (say 1 year).

3.2.2 Shunt power losses

Shunt power losses, mainly iron losses in transformers, may be regarded as substantially fixed losses, provided system voltages are kept reasonably constant.

3.2.3 Total power losses

Total losses are the sum of Series power losses as described in 3.2.1 and Shunt power losses as described in 3.2.2.

3.3 Application of Distribution Loss Factors

In accordance with Clause 3.6.3 (b) (3) of the NEC Distribution Loss Factors (DLFs)

“are to be used in the settlement process as a notional adjustment to the electrical energy, expressed in MWh, flowing at a distribution network connection point in a trading interval to determine the adjusted gross energy amount for that connection point in that trading interval in accordance with clause 3.15.4.”

That is, customers metered consumption data is adjusted to allow for electrical losses in the distributor's network. In accordance with the requirements of the NEC, they are only applied to the consumption of second tier customers in the National Electricity Market. The local retailer is responsible for paying for distribution losses that are not allocated to second tier customers.

In accordance with clause 3.6.3.(b) (2) of the NEC DLFs are either:

“(i) a site specific DLF ...for each distribution network connection point of the following types:

A a connection point for an embedded generator with actual generation of more than 10MW

B a connection point for an end-use with actual or forecast load of more than 40GWh or an electrical demand of more than 10MW

C a connection point for a market network service provider; and

D a connection point between two or more distribution networks; OR

(ii) derived ...using a volume weighted average of the average electrical energy loss between the transmission network connection point or virtual transmission node to which it is assigned and each distribution network connection point in the relevant voltage class assigned to that transmission network connection point or virtual transmission nodes...”

DLFs are also used to adjust the price paid to an embedded market generator to allow for the cost of electrical losses in the distributor's networks.

Electrical losses are incurred as power is transported along distribution wires. Losses increase with length and vary in proportion to the amount of power being transported. Average losses can vary from year to year due to cycles in network utilisation, network configuration, the shape of the load profile and the level of reactive power support.

It is not possible to measure the distribution losses incurred by individual customers. Accordingly, Tasmanian loss factors are calculated using a model that produces loss factors for different elements of a distribution network based on relevant network parameters. The elements considered include for example, zone and distribution transformers, voltage regulators, cables, and lines.

The loss levels determined by modelling within each network segment are calibrated against the overall measured losses for the network for the previous financial year, with an appropriate allowance for meter inaccuracy and theft. It is generally accepted that an allowance in the range 0.2% to 1.0% is appropriated to accommodate meter inaccuracy and theft.

In accordance with Clause 3.6.3 (g) of the NEC

“Distribution loss factors must be determined by the DNSP for all connection on its distribution network either individually, for all connection points assigned to a single transmission network connection point under clause 3.6.3(c), or collectively, for all connection points assigned to a transmission network connection point or a virtual transmission node and a particular distribution network connection point class under clause 3.6.3 (d) in accordance with:

- (1) the methodology developed, published and maintained by the Jurisdictional Regulator for the determination of distribution loss factors ; or*
- (2) where the Jurisdictional Regulator has not published a methodology under subparagraph (1) above, the methodology developed, published and maintained by the DNSP for the determination of the distribution loss factors.”*

As the Office of the Tasmanian Energy Regulator (OTTER) is the relevant jurisdictional regulator it is assumed that clause 3.6.3 (g) (2) will apply and that the methodology will be published and maintained by Aurora Energy.

In accordance with clause 3.6.3 (i) of the NEC

“Each year the DNSP must determine the distribution loss factors to apply in the next financial year in accordance with 3.6.3(g) and provide these to NEMMCO for publication by 1 April. Before providing the distribution loss factors to NEMMCO for publication, the DNSP must obtain the approval of the relevant Jurisdictional Regulator for the distribution loss factors it has determined for the next financial year.”

Accordingly, OTTER will be required to approve the DLF's prior to 1 April 05 for the period 1 July 2005 to 30 Jun 2006. DLF's presently being calculated on the basis of the 2002/03 financial year data will be applicable for any part of 2004/05.

Although DNSPs must determine the distribution loss factors that are to apply for the next financial year, in practical terms, loss factors of a network are determined by the physical characteristics of the network and by the accuracy of measurements of energy sales and purchases. Accordingly, detailed computation of the DLFs are not considered to be required to be undertaken if it is confirmed that the overall losses expressed as a percentage of energy purchases have not changed significantly from the previous year. Detailed recomputation of DLFs for the various voltage levels could be undertaken every three or four years.

4 CODE REQUIREMENT ON DISTRIBUTION LOSSES

The relevant clauses in the revised National Electricity Code with respect to Distribution Losses are set out in Section 12 Appendix B.

An issue for consideration in terms of the application of the National Electricity Code with respect to the Tasmanian network is determination of the part of the total Tasmanian Electricity Network that should be considered to be a distribution network in the context of the NEC and the part that should be considered to be a transmission network.

If the provisions of the National Electricity Code were ignored, philosophically, the concept of the application of Transmission Loss Factors is applicable to the parts of the network where losses are affected by the generation pattern on the system and thus affects the flow of current on the transmission network. On the other hand, Distribution Loss Factors are applicable to the parts of the network where power is taken from the transmission system and distributed to end-users and where that flow is not affected by generation schedules. The computation of Transmission Loss Factors requires extensive modelling to synthesise the variability of generation and transmission patterns. On the other hand, except with respect to the impact of any embedded generation, computation of Distribution Loss Factors can be undertaken with a single model of the network.

For the purpose of this report, due to the provisions of the structure of the National Electricity Code, the methodology that is presented assumes that all of the Transend network is considered to be a transmission network and that the interface between the transmission network and the distribution network coincides with the asset boundary between the Transend network and that of Aurora Energy.

As described in the Transend 2003 Planning Statement for the Tasmanian Power System, Dec 2003 Rev 2.1

“6.2 Existing transmission system

The transmission network is defined in the TEC as:

- *the electrical network operating at 220kV*
- *any part of the electrical network above 66kV that operates in parallel to and provides support to the 220kV network ; and*

- *the connection assets that connect the transmission network to the distribution system.*

In addition, the Regulator may deem any circuits above 66kV that do not meet the TEC definition to be part of the transmission system.

The transmission network is made up of:

- *a 220kV bulk transmission network which, with some 110kV transmission lines, provides corridors for transferring power from several major generation centres to major load centres and between major load centres; and*
- *a peripheral transmission system, including connection assets, which is largely radial and connects load centres or generators to the bulk transmission system. ...”*

“6.3 Transmission network connections

Hydro power stations are connected to the 220kV bulk transmission network at Farrell, Sheffield, Palmerston, Liapootah, Cluny and Gordon, and to the 110kV network at Trevallyn and in the Derwent area. Bell Bay thermal power station is connected to George Town Substation at 110kV....

Main load centres are connected to the 220kV bulk transmission network at George Town, Chapel St (Hobart), Sheffield (Devenport and Burnie) and Hadspen (Launceston and north-eastern areas). Other load centres are connected via the 110kV peripheral transmission network.

Power transfers take place between the bulk transmission network and the peripheral transmission network via 220/110kV auto-transformers at Sheffield, Burnie, Palmerston, George Town, Chapel St, Farrell and Hadspen. The 110kV transmission network provides support to the 220kV bulk transmission network.”

Accordingly, although the Transend Transmission system essentially operates at 220kV and 110kV, Aurora Energy takes its supply from the Transend network at 44kV, 33kV, 22kV, 11kV and some 6.6kV.

Participants in the other states of the National Electricity Market generally take their supply at 132kV or 110kV with loss factors applicable to the essentially radial supply from the 132kV or 110kV networks to the zone substations connected to the 132kV or 110kV networks being

treated as being part of the distribution network and not part of the transmission network. The only exceptions to this is the areas where the 132kV or 110kV network provides support to the parallel transmission system or with respect to zone substations connected to the 132kV transmission system.

In the other states, there is generally a significant separate 132kV/110kV network that supports a subtransmission system and relevant zone substations.

In NSW for example, EnergyAustralia, the DNSP supplying a major part of the Sydney region and the northern region covering Newcastle and the Hunter Valley,

In Tasmania, due to the distributed nature of embedded generation from Hydro's system, the 110kV network provides a large supporting facility to the 220kV backbone system and generated power flows in various directions on the 110kV network dependent upon the despatch of the various generation plant. The transformers and switchgear at the 110kV substations are treated as connection assets.

As a result, Transend have computed marginal loss factors at each of the transmission connection points at which Aurora Energy takes supply. These are generally on the low voltage side of the various terminal substations rather than on the high voltage side. Normally, marginal loss factors in the NEM are applied at the 132kV /110 kV level and the losses associated with the terminal substation and zone substations providing radial supply to the Aurora network would be considered to be part of the distribution network and would have a distribution loss factor applicable.

As Aurora data systems do not have a relationship between the customer connection and the appropriate transmission connection point, to apply the marginal loss factors provided by Transend, Aurora Energy will need to compute a sales weighted average of the various transmission connection point marginal loss factors and smear the transmission marginal loss factor amongst all customers. This could be achieved by the application of a virtual transmission node either for the whole state or for two regions (say north and south). Aurora Energy would need to make an application to NEMMCO to have a virtual transmission node(s) determined.

A further issue is the detail of the methodology utilised to compute the applicable marginal loss factors at the transmission network connection point. The extent of variability of the marginal

loss factors and treatment of allocation of shunt losses associated with transformers requires examination. The present methodology may not result in equitable marginal loss factors when applied to the medium voltage terminals of transmission connection points.

The NEC requirement with respect to Intra-Regional Loss Factors is described in Section 13 Appendix C.

5 AVERAGE DLF

The detailed methodology used in calculating volume weighted DLF is described in Section 11 Appendix A. This method is similar to the methodology that has been used by electricity distributors of the National Electricity Market since electricity industry deregulation in 1994 and is in accordance with the requirements as set out in Section 3.6.3 Distribution Losses of the NEC as shown in Section 12.

In accordance with clause 3.6.3 (h) (4) of the NEC:

“The distribution loss factor for a distribution network connection point ...is determined using the average electrical energy loss between the distribution network connection point and the transmission network connection point to which it is assigned in the financial year in which the distribution loss factor is to apply.”

The philosophy of utilising average DLF's is that an average DLF is applied at each of the respective voltage levels on the system. The relevant connection points are classified as:

- Subtransmission system
- Zone substation direct connection
- High voltage feeder
- Distribution transformer
- Low voltage network

The revised National Electricity Code requires site specific loss factors to be derived for qualified end users and hence it is necessary to de-average network losses between qualified end users and general users.

To achieve this, the methodology has to be adjusted as follows:

- The losses on each segment of the network due to all listed specific customers is aggregated and subtracted from the total calculated network losses on each segment of the network.
- All site specific customer sales in each segment of the network is aggregated and subtracted from the total network sales on each segment of the network.
- The balance in the network losses and sales is then used to determine the volume weighted average DLFs for general users.

6 SITE SPECIFIC DLF FOR QUALIFIED END USERS

This section describes the methodology used in determining the “site specific” distribution loss factors for the qualified customers in the code.

At present most of the qualified site specific customers are connected to network configurations given below:

- Customers connected directly to sub transmission network off terminal stations
- Customers connected to shared sub transmission network
- customers connected to dedicated high voltage feeder
- Customers connected to shared high voltage feeder

The main steps are as follows:

1. Model network from terminal station to customer’s point of common coupling (PCC)
2. Evaluate peak demand losses using a power system modelling package (eg DINIS) and actual demand recorded in the last financial year.
3. Determine peak demand losses to the site-specific customers and the rest of the network customers on the network under consideration. This can be done using “customer energy” or “Customer Demand” as the principle driver for allocation.
4. Determine the site-specific customer’s and rest of network annual load factor
5. Calculate loss load factor employing empirical formulae
6. Calculate annual losses using demand losses and LLF:
$$\text{Annual Losses (MWh)} = \text{Demand losses (MW allocated)} * \text{LLF} * 8760\text{hrs}$$
7. Determine annual energy consumption. For site-specific DLF calculation this is obtained from last financial year’s billing data.
8. Calculate customer specific DLF using the formula:

$$\text{Customer specific DLF} = 1 + \frac{\text{(Energy losses (MWh))}}{\text{(Energy Consumption (MWh))}}$$

7 ALLOCATION OF 'TOP DOWN LOSSES' UTILISING THE CALCULATED 'BOTTOM UP TECHNICAL LOSSES'

The difference between the total energy purchased by the distribution business from all sources and the total energy consumed by users connected to the network is generally known as the 'Top Down' losses.

The 'Bottom Up' measurement, which is based on modelling the network into segments, is used to establish the losses for various classes of customers, ie those connected to the network at different voltage levels. Models have been set up at the different voltage levels and certain assumptions and approximations have been assumed to determine the bottom up losses. See Appendix A for the methodology in determining the theoretical losses.

The accuracy of the 'Bottom Up' measurement is judged based on reconciliation with the "Top Down' measurement through acceptance of the level of "Imeasurable Losses"). These immeasurable losses include energy loss due to theft, meter errors, unbilled customers and errors in unmetered supply. It is generally accepted that immeasurable losses are the responsibility of the distributor as they reflect on the distributor's management efficiency, and hence should not be included as part of the DLF calculation. However, they need to be estimated to facilitate reconciliation between "Top Down' and Bottom Up' measurements.

Even when allowing for a certain level of immeasurable losses, there still may be some discrepancy between the 'Top Down' and the 'Bottom Up' calculated losses. This is due to the fact that there are tolerances in the 'Bottom Up' approach because of the assumptions and approximations used in the modeling and the use of empirical formulas.

For a fair and reasonable allocation of losses, it is considered appropriate to reconcile the 'Bottom Up' losses and the 'Top Down' losses by using a calibration factor for each segment of the network after allowing for an appropriate level of unaccounted losses or energy theft.

8 FORWARD-LOOKING DISTRIBUTION LOSS FACTORS

As per revised National Electricity Code, DLFs shall be forward-looking estimates for the period in which they are to apply.

To calculate forward-looking DLFs the following steps are used.

- 1 Total energy sales over the period the DLFs will apply is forecast.
- 2 Network maximum demand over the period the DLF will apply is forecast
- 3 Future distribution load factors (related to customer load patterns) are forecast based on (1) and (2) above.
- 4 Future trends in low voltage network losses are estimated by considering possible changes in load patterns and network expansion. Past low voltage energy losses are used as the starting point and increased in accordance with trends.
- 5 Future trends in distribution substation losses are estimated by considering possible changes in load patterns, equipment utilisations, asset replacement programs and network expansion. Again, past distribution substation energy losses are used as the starting point and increased in accordance with trends.
- 6 Trends over time in medium-voltage feeder losses are determined by considering changes in load patterns, changes in power factor, feeder utilisations and the effect of new proposed feeders. Again past feeder energy losses are used as the starting point and increased in accordance with trends.
- 7 Future proposed subtransmission and zone substation network arrangements are used to determine future energy and loss based on forecast energy sales plus downstream losses. Subtransmission and zone substation networks are planned in advance more precisely and therefore changes in losses in this part of the network are more accurately forecast.
- 8 Finally forecast energy losses on each part of the network are divided by forecast sales to determine forward-looking loss factors.

9 TRANSMISSION LOSS FACTORS

As referred to in Section 4, given the provisions of the NEC, issues arise with respect to the relationship between Distribution Loss Factors and Transmission Loss Factors.

A review needs to be initiated by Aurora and Transend with a view to reaching a resolution prior to Tasmania's entry to the National Electricity Market with respect to the use of Transmission Loss Factors at the various connection points in order to confirm:

- i) That the use of marginal loss factors at the transmission connection points by Transend is in compliance with the NEC.
- ii) That the methodology utilised for determination of the marginal loss factors is appropriate and to examine whether this will result in equitable marginal loss factors when applied to the medium voltage terminals of transmission connection points. In particular, consideration be given to the allocation of fixed losses between Aurora Energy and site-specific customer sites and whether the NEC methodology is appropriate.
- iii) The extent to which the application of marginal loss factors will result in over- or under-recovery of transmission losses by Transend and the most appropriate methodology for carrying out any adjustment.
- iv) The appropriateness of application of individual marginal loss factors at each connection point between Transend's network and the Aurora network and whether Aurora (either within the Networks or Retails Divisions) has any exposure to commercial risk.
- v) Whether Aurora Energy should seek the establishment of a TLF at a virtual node(s).

10 CONCLUSION

Issues associated with computation of distribution loss factors in Tasmania have been presented. It is recommended that endorsement be sought from the Office of the Tasmanian Energy Regulator (OTTER) to endorse the proposed procedure and to advise on the issues raised. In particular, the following matters require consideration:

- a) The methodology described in this report be accepted by OTTER

- b) A review is initiated by Aurora Energy and Transend with a view to reaching a resolution prior to Tasmania's entry to the National Electricity Market with respect to the Transmission Loss Factors issues referred to in Section 9.

11 APPENDIX A

AVERAGE DISTRIBUTION LOSS FACTOR CALCULATION METHODOLOGY

11.1 INTRODUCTION

The methodology for calculating DLFs determines an average loss level for five different network segments based on modelling of the segments. A DLF is calculated for each network segment and customers are allocated the appropriate DLF for the network segment to which their electrical installation is connected. The DLF categories relating to the five network segments are:

- $D_{\text{Subtx-Line}}$ is the distribution loss factor to be applied to a second tier customer or market customer connected to a subtransmission line (at 44kV or 33kV).
- $DLF_{\text{Zone Sub}}$ is the distribution loss factor to be applied to a second tier customer or market customer connected to the lower voltage side of a zone substation
- $DLF_{\text{HV-Fdr}}$ is the distribution loss factor to be applied to a second tier customer or market customer connected to a distribution line from a zone substation at voltages of 22kV, 11 kV or 6.6kV.
- $DLF_{\text{Dist-Sub}}$ is the distribution loss factor to be applied to a second tier customer or market customer connected to the lower voltage terminals of a distribution transformer (at 240/415V).
- $DLF_{\text{LV-Lines}}$ is the distribution loss factor to be applied to a second tier customer or market customer connected to a low voltage line at 240/415V.

DLF is expressed as:

$$DLF = \frac{\text{Calculated Annual Losses (kWh) in the Category}}{\text{Annual Sales in Category} + \text{Annual Sales Downstream of Category}}$$

$$A_{L-n} = \text{Annual Losses in the Category } n$$

Where the "Sales" is defined as:

Sales by all Retailers within a Distribution Company's franchise area + Cross Boundary Sales
not settled within the Pool

Losses in an electrical system can be classified into two categories:

- Current depending losses
 - Copper Losses = $(\text{Current})^2 * \text{Resistance of the circuit / plant item}$
- Voltage depending losses
 - Iron losses of transformers
 - Dielectric losses (insulation materials)
 - Due to corona.

The distribution network consists of a large number of loads, sources, various types and sizes of conductors and transformers. An "average" approach is to be adopted with the following assumptions made during the calculation:

- All load currents maintain a constant ratio to the total current
- The voltage at every source bus remain constant in magnitude
- Power factor remains constant

Among the losses, the Copper Losses and the Iron Losses are the main components to be included in the overall Loss Factor of the supply system in the distribution network. Copper Losses are variable losses as they change with $(\text{Current})^2$. The Iron losses of the transformer is the fixed losses since the voltage is assumed constant all the time.

Based on the above assumptions, the actual losses of the circuit / plant item can be calculated from the Total Losses assuming maximum current to flow through that circuit / plant item during the whole period. This is done by the introduction of the Load Loss Factor (LLF) that is defined as:

$$\text{Load Loss Factor} = \frac{\text{Actual loss (kWh) during period}}{\text{Loss (kWh) assuming maximum current to flow during whole of period}}$$

Alternative, there are empirical methods giving the relationship between the Load Loss Factor (LLF) and the Load Factor (LF). The formulas used for the calculations are to be shown in the relevant clauses below.

The methods outlined in this document are to be used to calculate the Loss Components for the various categories (based on circuits, plant items and voltage levels) in the distribution network. These Loss Components will then be used to calculate the overall DLF's for the various customer connections.

11.2 SUB-TRANSMISSION LINE LOSSES

Terminal Station 44kV, 33kV or 22kV Bus

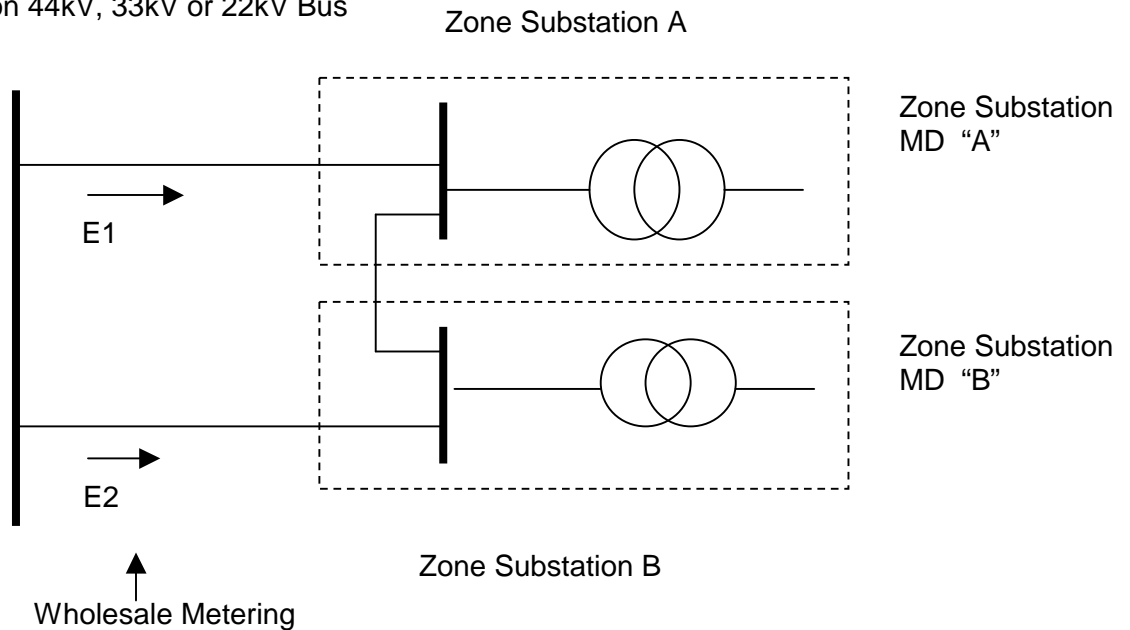

The standard methodology to calculate the loss component for the sub-transmission loop / lines is detailed as below:

- Set up full network model for all sub-transmission lines in each loop
- Obtain loop maximum demand MD
- Run load flow to determine losses (LMD) at loop MD
- Determine Load Factor (LF) for the sub-transmission loop
- Calculate the Load Loss Factor (LLF) using metered data or using the formula

$$LLF = 0.3 * LF + 0.7 * LF^2$$
 (Factor k = 0.3 may be replaced with calibrated factor if available)
- Calculate the annual losses (A_{L-1}) on the sub-transmission loop

$$= LMD * LLF * 8760$$

Where 8760 = 24 hours * 365 days

11.3 ZONE SUBSTATION LOSSES

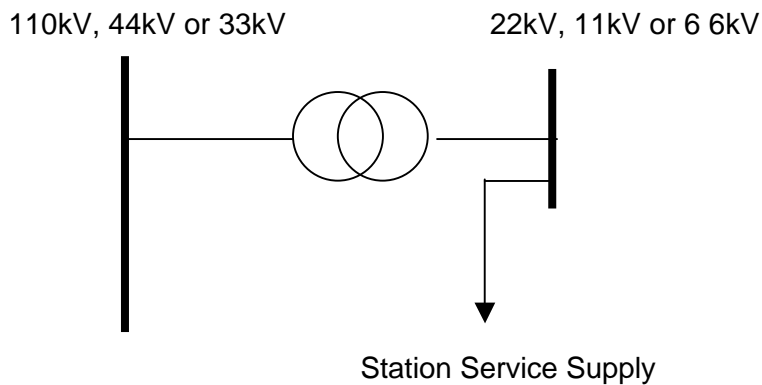

The standard methodology to calculate the loss component for the Zone Substation is detailed as below:

- Set up network model for the Zone Substation Transformers
- Obtain zone substation maximum demand MD
- Run load flow to determine losses at MD (LMD)
- Determine Load Factor (LF) for Zone Substation Transformers
- Calculate the Load Loss Factor (LLF) using metered data or using the formula
$$\text{LLF} = 0.3 * \text{LF} + 0.7 * \text{LF}^2$$

(Factor k = 0.3 may be replaced with calibrated factor if available)

- Calculate Annual Copper Losses (LC) for the transformer

$$\text{LC} = \text{LC}_m * \text{LLF}$$

- Add fixed Iron Losses (LI) for the Transformer
- Add Station Service Supply (LSS) losses
- Calculate Total Annual Losses (A_{L-4}) for the Zone Substation Transformer

$$A_{L-2} = (\text{LC} + \text{LI} + \text{LSS}) * 8760$$

Where 8760 = 24 hours * 365 days

11.4 HIGH VOLTAGE DISTRIBUTION LINE LOSSES

Zone Substation 44kV. 22kV
or 11kV or 6.6kV Bus

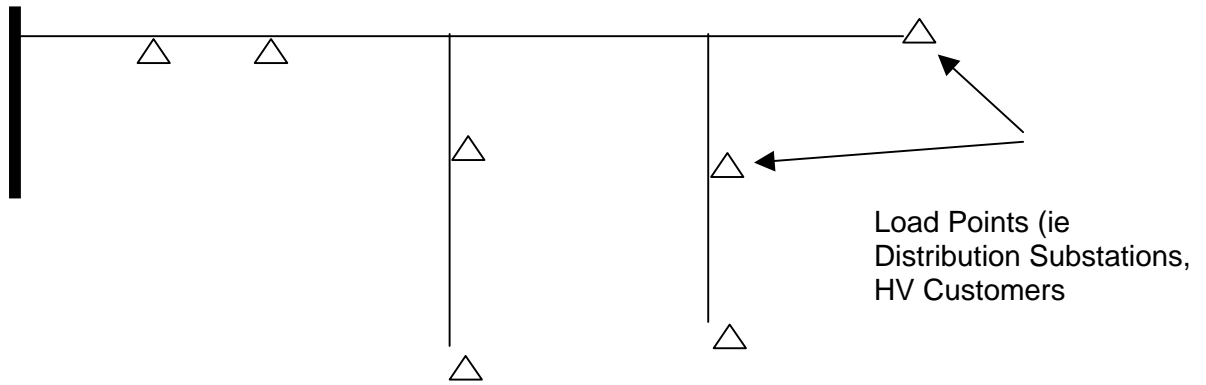

The standard methodology to calculate the loss component for the High Voltage Distribution Network is detailed as below.

- Determine the feeder current (I_m) at Maximum Demand (MD)
- Carry out load flow for feeder at Maximum Demand current and establish power loss (LMD).
- Determine Load Factor (LF) of the HV feeder
- Calculate the Load Loss Factor (LLF) either using metered data or using the formula

$$LLF = 0.2 * LF + 0.8 * LF^2$$

(Factor k = 0.2 may be replaced with calibrated factor if available)

- Calculate the Annual Losses (A_{L-3}) for the feeders off the zone substation:

$$A_{L-3} = (LMD) * LLF * 8760$$

11.5 DISTRIBUTION SUBSTATION LOSSES

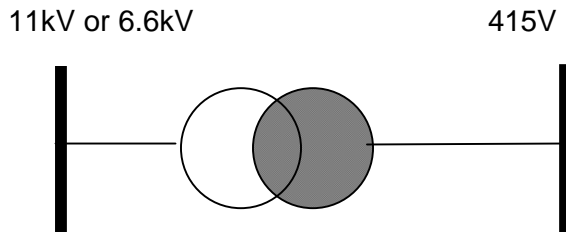

The standard methodology to calculate the loss component for the Distribution Transformers is detailed as below.

- Determine average MD of transformers
- Determine typical Copper Losses (LC_R) of the transformer at its nameplate rating
- Calculate Copper Losses (LC_m) for the transformer at MD

$$LC_m = LC_R * (MD / \text{Transformer Nameplate Rating})^2$$
- Estimate the Load Factor (LF) of the transformer
- Calculate the Load Loss Factor (LLF) either using metering data or using the formula

$$LLF = 0.2 * LF + 0.8 * LF^2$$

(Factor k = 0.2 may be replaced with calibrated factor if available)
- Calculate Annual Copper Losses (LC) for the transformer

$$LC = LC_m * LLF$$
- Add fixed Iron Losses (LI) for the Transformer
- Calculate Total Annual Losses (A_{L-4}) of the Transformer

$$A_{L-4} = (LC + LI) * 8760$$

Where 8760 = 24 hours * 365 days
- Total Losses for all distribution transformers can then be calculated by summing the annual losses for each individual transformer or type of transformer.

11.6 LOW VOLTAGE LOSSES

The losses in the low voltage network are based on the energy balance for the whole system. The losses are calculated as a residual of the subtransmission and primary distribution network losses. The calculated losses in low voltage networks and installations include the following:

- Losses in low voltage network
- Losses in consumer mains
- Losses due to metering error and losses in load control equipment
- Street lighting energy consumption
- Non-metered energy use and internal losses in substations
- Unbilled electricity adjustment
- Non-technical losses

11.7 DLF CALCULATION AND APPLICATION RULES

DLFs are calculated by apportioning losses at the various customer connection categories according to the sales achieved for that category and downstream.

The table below shows the formulas to be used to calculate the DLF's and the factors to be applied to the customer.

Table 1 DLF Calculation Formulae

Customer Connection on	Calculated Annual Losses in Category	Annual Sales (Retail + Cross Boundary Sales)	Formulas of calculating DLF's for each category	Total Amount to be applied to Customer
Sub-Transmission Line (88kV, 33kV)	A_{L-1}	Sales _{.1}	$D_{\text{Subtx-Line}} = \frac{A_{L-1}}{(\text{Sales}_{.1} + \text{Sales}_{.2} + \text{Sales}_{.3} + \text{Sales}_{.4} + \text{Sales}_{.5})}$	Subtx-Line
Zone Substation	A_{L-2}	Sales _{.2}	$DLF_{\text{Zone Sub}} = \frac{A_{L-2}}{(\text{Sales}_{.2} + \text{Sales}_{.3} + \text{Sales}_{.4} + \text{Sales}_{.5})}$	Subtx-Line + Zone-Sub
HV Feeder (22kV/ 11kV)	A_{L-3}	Sales _{.3}	$DLF_{\text{HV-Fdr}} = \frac{A_{L-3}}{(\text{Sales}_{.3} + \text{Sales}_{.4} + \text{Sales}_{.5})}$	Subtx-Line + Zone-Sub + HV-Fdr
Distribution Substation	A_{L-4}	Sales _{.4}	$DLF_{\text{Dist-Sub}} = \frac{A_{L-4}}{(\text{Sales}_{.4} + \text{Sales}_{.5})}$	Subtx-Line + Zone-Sub + HV-Fdr + Dist-Sub
LV Network (415/240V)	A_{L-5}	Sales _{.5}	$DLF_{\text{LV-Lines}} = \frac{A_{L-5}}{\text{Sales}_{.5}}$	Subtx-Line + Zone-Sub + HV-Fdr + Dist-Sub + LV-Lines

12 APPENDIX B

CODE REQUIREMENTS ON DISTRIBUTION LOSSES

3.6.3 Distribution losses

(a) *Distribution losses are electrical energy losses incurred in the conveyance of electricity over a distribution network.*

(b) *Distribution loss factors:*

(1) *notionally describe the average electrical energy losses for electricity transmitted on a distribution network between a distribution network connection point and a transmission network connection point or virtual transmission node for the financial year in which they apply;*

(2) *will be either:*

(i) *a site specific distribution loss factor derived in accordance with the methodology determined by the Jurisdictional Regulator or the Distribution Network Service Provider pursuant to clause 3.6.3(h), for each distribution network connection point of the following types:*

A. *a connection point for an embedded generating unit with actual generation of more than 10MW, based on the most recent data available for a consecutive 12 month period at the time of determining the distribution loss factor. Where relevant data is not available for a consecutive 12 month period as a transmission network connection point is newly established or has been modified, a Network Service Provider may determine whether an embedded generating unit has generation of more than 10MW, based on its best projection of generation in the financial year in which the distribution loss factor is to apply, taking into account the terms of the relevant connection agreement;*

B. *a connection point for an end-user with actual or forecast load of more than 40GWh or an electrical demand of more than 10MW, based on the most recent data available for a consecutive 12 month period at the time of determining the distribution loss factor. Where relevant data is*

not available for a consecutive 12 month period as a transmission network connection point is newly established or has been modified, a Network Service Provider may determine whether an end-user has load of more than 40GWh or forecast peak load of more than 10MW, based on its best projection of load in the financial year in which the distribution loss factor is to apply, taking into account the terms of the relevant connection agreement;

C. a connection point for a market network service provider; and

D. a connection point between two or more distribution networks; OR

(ii) derived, in accordance with the methodology determined by the Jurisdictional Regulator or the Distribution Network Service Provider pursuant to clause 3.6.3(h), using the volume weighted average of the average electrical energy loss between the transmission network connection point or virtual transmission node to which it is assigned and each distribution network connection point in the relevant voltage class assigned to that transmission network connection point or virtual transmission node, for all connection points on a distribution network not of a type described in clause 3.6.3(b)(2)(i);

(3) are to be used in the settlement process as a notional adjustment to the electrical energy, expressed in MWh, flowing at a distribution network connection point in a trading interval to determine the adjusted gross energy amount for that connection point in that trading interval, in accordance with clause 3.15.4.

(c) Each Distribution Network Service Provider must assign each connection point on its distribution network, of a type described in clause 3.6.3(b)(2)(i), to a single transmission network connection point taking into account normal network configurations and predominant load flows.

(a1) [Deleted]

(d) Each Distribution Network Service Provider must assign each connection point on its distribution network, not of a type described in clause 3.6.3(b)(2)(i):

(1) where practicable, to a single transmission network connection point or otherwise, to a virtual transmission node, taking into account normal network configurations and predominant load flows; and

(2) to a class of distribution network connection points based on the location of, voltage of and pattern of electrical energy flows at the distribution network connection point.

(e) So far as practicable, the assignment of connection points on the distribution network to:

(1) transmission network connection points under clause 3.6.3(c); or

(2) transmission network connection points or virtual transmission nodes and a class of distribution network connection points under clause 3.6.3(d),

must be consistent with the geographic boundaries of the pricing zones determined in accordance with clause 6.13.2 for use in distribution service pricing, and the voltage levels incorporated within these pricing zones.

(f) The assignment of connection points on a distribution network:

(1) to a single transmission network connection point under clause 3.6.3(c); or

(2) to a transmission network connection point or virtual transmission node and a class of distribution network connection points under clause 3.6.3(d),

is subject to the approval of the relevant Jurisdictional Regulator and the Distribution Network Service Provider must inform NEMMCO of such approved assignments.

(g) Distribution loss factors must be determined by a Distribution Network Service Provider for all connection points on its distribution network either individually, for all connection points assigned to a single transmission network connection point under clause 3.6.3(c), or collectively, for all connection points assigned to a transmission network connection point or a virtual transmission node and a particular distribution network connection point class under clause 3.6.3(d), in accordance with:

(1) the methodology developed, published and maintained by the Jurisdictional Regulator for the determination of distribution loss factors; or

(2) where the Jurisdictional Regulator has not published a methodology under subparagraph (1) above, the methodology developed, published and maintained by the Distribution Network Service Provider for the determination of distribution loss factors.

(h) The methodology for the determination of distribution loss factors referred to in clause 3.6.3(g) must be developed having regard to the following principles:

(1) The aggregate of the adjusted gross energy amounts for a distribution network, determined in accordance with clause 3.15.4 using the distribution loss factors for the financial year in which the distribution loss factors are to apply should equal, as closely as is reasonably practicable, the sum of:

A. the amount of electrical energy, expressed in MWh, flowing at all connection points in the distribution network in the financial year in which the distribution loss factors are to apply; and

B. the total electrical energy losses incurred on the distribution network in the financial year in which the distribution loss factors are to apply.

(2) The methodology used to determine distribution loss factors for a financial year should incorporate provisions requiring a Distribution Network Service Provider to undertake a reconciliation between the aggregate of the adjusted gross energy amounts for its distribution network for the previous financial year determined in accordance with clause 3.15.4 using the distribution loss factors that applied for connection points in that distribution network in the previous financial year and the sum of:

(i) the amount of electrical energy, expressed in MWh flowing at all connection points in its distribution network in the previous financial year; and

(ii) the total electrical energy losses incurred on its distribution network in the previous financial year.

(3) *The distribution loss factor for a distribution network connection point, other than those described in clause 3.6.3(b)(2)(i), is determined using a volume weighted average of the average electrical energy loss between the transmission network connection point or virtual transmission node to which it is assigned and each distribution network connection point in the relevant class of distribution network connection points assigned to that transmission network connection point or virtual transmission node for the financial year in which the distribution loss factor is to apply.*

(4) *The distribution loss factor for a distribution network connection point described in clause 3.6.3(b)(2)(i) is determined using the average electrical energy loss between the distribution network connection point and the transmission network connection point to which it is assigned in the financial year in which the distribution loss factor is to apply.*

(5) *In determining the average electrical energy losses referred to in clause 3.6.3(h)(3) and (4) above, the Distribution Network Service Provider must use the most recent actual load and generation data available for a consecutive 12 month period but may adjust this load and generation data to take into account projected load and / or generation growth in the financial year in which the distribution loss factors are to apply.*

(6) *In determining distribution loss factors, flows in network elements that solely or principally provide market network services will be treated as invariant, as the methodology is not seeking to calculate the marginal losses within such network elements.*

(i) *Each year the Distribution Network Service Provider must determine the distribution loss factors to apply in the next financial year in accordance with clause 3.6.3(g) and provide these to NEMMCO for publication by 1 April. Before providing the distribution loss factors to NEMMCO for publication, the Distribution Network Service Provider must obtain the approval of the relevant Jurisdictional Regulator for the distribution loss factors it has determined for the next financial year.*

13 APPENDIX C

CODE REQUIREMENTS ON INTRA-REGIONAL LOSSES

3.6.2 Intra-regional losses

(a) *Intra-regional losses are electrical energy losses that occur due to the transfer of electricity between a regional reference node and transmission network connection points in the same region.*

(b) *Intra-regional loss factors:*

(1) *notionally describe the marginal electrical energy losses for electricity transmitted between a regional reference node and a transmission network connection point in the same region for a defined time period and associated set of operating conditions;*

(2) *will be a single static intra-regional loss factor that applies for a financial year derived in accordance with the methodology determined by NEMMCO pursuant to clause 3.6.2(d) for each transmission network connection point; and*

(3) *may, with the agreement of the Jurisdictional Regulator, be averaged over an adjacent group of transmission network connection points within a single region. If averaging is used, the relevant transmission network connection points will be collectively defined as a virtual transmission node with a loss factor calculated as the volume weighted average of the transmission loss factors of the constituent transmission network connection points.*

(c) *An intra-regional loss factor is to be used as a price multiplier that can be applied to the regional reference price to determine the local spot price at each transmission network connection point and virtual transmission node.*

(d) *NEMMCO must determine, publish and maintain, in accordance with Code consultation procedures, a methodology for the determination of intra-regional loss factors to apply for a financial year for each transmission network connection point.*

(e) *In preparing the methodology referred to in clause 3.6.2(d) above, NEMMCO must implement the following principles:*

(1) *Intra-regional loss factors are to apply for a financial year.*

- (2) *An intra-regional loss factor must, as closely as is reasonably practicable, describe the average of the marginal electrical energy losses for electricity transmitted between a transmission network connection point and the regional reference node in the same region for each trading interval of the financial year in which the intra-regional loss factor applies.*
- (2A) *Intra-regional loss factors must aim to minimise the impact on the central dispatch of generation and scheduled load compared to that which would result from a fully optimised dispatch process taking into account the effect of losses.*
- (3) *Forecast load and generation data for the financial year for which the intra-regional loss factor is to apply must be used. The forecast load and generation data used must be that load and generation data prepared by NEMMCO pursuant to clause 3.6.2A.*
- (4) *The load and generation data referred to in paragraph (3) above must be used to determine marginal loss factors for each transmission network connection point for each trading interval in the financial year to which the load and generation data relates.*
- (5) *The intra-regional loss factor for each transmission network connection point is determined using a volume weighted average of the marginal loss factors for the transmission network connection point.*
- (6) *In determining the intra-regional loss factor for a transmission network connection point, flows in network elements that solely or principally provide market network services will be treated as invariant, as the methodology is not seeking to calculate the marginal losses within such network elements.*
- (f) *Subject to clause 3.6.2B, NEMMCO must calculate intra-regional loss factors for each transmission network connection point for each financial year in accordance with the methodology prepared and published by NEMMCO under clause 3.6.2(d).*
- (f1) *By 1 April in each year, NEMMCO must publish the intra-regional loss factors revised under clause 3.6.2(f) and to apply for the next financial year.*

(g) NEMMCO must, in accordance with the Code consultation procedures, determine, publish and maintain the methodology which is to apply to the calculation of average transmission loss factors, determined in accordance with clause 3.6.2(b)(3), for each virtual transmission node proposed by a Distribution Network Service Provider.

(h) As soon as practicable after the publication of the methodology referred to in clause 3.6.2(g), and thereafter by 1 April in each year, NEMMCO must calculate and publish the transmission loss factors for each virtual transmission node, determined in accordance with clause 3.6.2(b)(3), that are to apply for the next financial year.

(i) Notwithstanding clauses 3.6.2(a) to (f1), NEMMCO must:

(1) determine an intra-regional loss factor in the financial year in which the intra-regional loss factor is to apply for a transmission network connection point which is established in that financial year in accordance with the procedure for establishing connection set out in clause 5.3, provided that NEMMCO did not determine an intra-regional loss factor for the transmission network connection point pursuant to clause 3.6.2(f1) in the financial year preceding that in which the connection point is established; or

(2) revise an intra-regional loss factor in the financial year in which the intra-regional loss factor is to apply for a transmission network connection point which is modified in that financial year in accordance with the procedure for modifying connection set out in clause 5.3, provided that, in NEMMCO's reasonable opinion, the modification to that connection point results in a material change in the capacity of the connection point.

(j) NEMMCO must, where required to determine the intra-regional loss factor for an established or modified transmission network connection point under clause 3.6.2(i), do so as far as practicable in accordance with the methodology published by NEMMCO pursuant to clause 3.6.2(d).

(k) For the purposes of clause 3.6.2(j), the forecast load and generation data used to calculate the intra-regional loss factor for the transmission network connection point must be determined using the forecast load and generation data determined by NEMMCO under clause 3.6.2A for other transmission network connection points in the same region for that financial year adjusted to take into account the effect of the established or modified connection point. Notwithstanding this clause 3.6.2(k), Code Participants must comply with their obligations with respect to the

provision of information to NEMMCO, for the purpose of determining new or revised intra-regional loss factors for connection points that are established or modified during the financial year in which the intra-regional loss factors are to apply, specified by the methodology developed and published by NEMMCO under clause 3.6.2A.

(l) In the case of a connection point that is established in the financial year in which the intra-regional loss factor is to apply:

(1) the intra-regional loss factor determined by NEMMCO in accordance with clause 3.6.2(i) will apply from the time the intra-regional loss factor is determined and published by NEMMCO; and

(2) NEMMCO must use reasonable endeavours to determine and publish the intra-regional loss factor at least 45 business days prior to the commencement of operation of the established connection point, where the relevant Code Participants comply with any applicable requirements and deadlines for the provision of information to NEMMCO specified by the methodology published by NEMMCO under clause 3.6.2A.

(m) In the case of a connection point that is modified in the financial year in which the intra-regional loss factor is to apply:

(1) the intra-regional loss factor determined by NEMMCO in accordance with clause 3.6.2(i) will apply from the date when the modification to the connection point takes effect; and

(2) NEMMCO must use reasonable endeavours to publish the intra-regional loss factor at least 45 business days prior to the date when the modification to the connection point takes effect, where the relevant Code Participants comply with any applicable requirements and deadlines for the provision of information to NEMMCO specified by the methodology published by NEMMCO under clause 3.6.2A.

(n) For the avoidance of doubt, where NEMMCO determines an intra-regional loss factor for a transmission network connection point under clause 3.6.2(i), which is to apply in the financial year in which the transmission network connection point is established or modified, the intra-regional loss factors for all other transmission network connection points for that financial year, determined in accordance with clauses 3.6.2(a) to (g), must remain unchanged.