



GIS REPLACEMENT
SOUTH MORANG TERMINAL STATION
TRANSMISSION REVENUE RESET (TRR) PROJECT SCOPING



REVISION HISTORY

REV	DESCRIPTION	PREPARED BY	CHECKED BY	APPROVED BY	DATE
A	First issue	[C-I-C]	[C-I-C]	[C-I-C]	20/09/2019
A	Second issue	[C-I-C]	[C-I-C]	[C-I-C]	25/09/2019

PREPARED FOR

[C-I-C]

T: [C-I-C]
E: [C-I-C]
A: L31, 2 Southbank Boulevard, Southbank, VIC, 3006

RESPOND TO

[C-I-C]

M: [C-I-C]
E: [C-I-C]
A: L1, 315 Ferntree Gully Road, Mount Waverly VIC 3149

GENERAL ADMINISTRATION

P: 1300 273 797
E: admin@APDeng.com.au

TABLE OF CONTENTS

1.	INTRODUCTION	4
2.	LIMITATIONS.....	4
3.	ASSUMPTIONS	5
4.	OPTION 1 – REPLACE ALL 500KV GIS WITH AIS.....	5
4.1.	OUTLINE OF PROJECT	5
4.2.	OPTION 1 – PLANNING ESTIMATE.....	7
5.	OPTION 2 – REPLACE ALL 500KV GIS WITH INDOOR GIS	8
5.1.	OUTLINE OF PROJECT	8
5.2.	OPTION 2 – PLANNING ESTIMATE.....	8
6.	OPTION 3 – STAGED REPLACEMENT OF 500KV GIS WITH AIS	9
6.1.	OUTLINE OF PROJECT	9
6.2.	OPTION 3 – PLANNING ESTIMATE.....	9
7.	OPTION 4 – STAGED REPLACEMENT OF 500KV GIS WITH GIS	10
7.1.	OUTLINE OF PROJECT	10
7.2.	OPTION 4 – PLANNING ESTIMATE.....	10
8.	REFERENCES	11
	APPENDIX A.....	12
	APPENDIX A.1.....	12
	APPENDIX A.2.....	19
	APPENDIX A.3.....	24
	APPENDIX A.4.....	26
	APPENDIX B.	28
	APPENDIX B.1.....	28
	APPENDIX B.2.....	39
	APPENDIX B.3.....	44
	APPENDIX B.4.....	46

Disclaimer

This document has been exclusively developed for the Client named in this report. While all professional care has been undertaken in preparing this document, APD Engineering accepts no liability for loss or damages incurred as a result of reliance placed upon its content by any third party.

Copyright © 2019:

Alliance Power and Data Pty. Ltd. (T/A APD Engineering), All rights reserved.

This document is subject to copyright. Use, copying or transmission of this document in whole or part without the prior written permission of APD Engineering constitutes an infringement of copyright.

EXECUTIVE SUMMARY

AusNet Services has engaged APD Engineering to prepare project scopes and estimates relating to options for the replacement of poor condition GIS primary and secondary equipment at South Morang Terminal Station (SMTS) for inclusion in AusNet Services' 2022 – 2027 Transmission Revenue Reset.

APD Engineering has reviewed a functional scope prepared by AusNet Services and developed detailed scopes and estimates for each planning option required by AusNet Services.

In undertaking this scoping work, APD Engineering has assessed that the options appear credible and can be constructed through the development of a possible construction sequencing that limits the risk of interruption to supply to the 500kV backbone transmission network connected through the station and reduces the need for coincident 500kV outages.

The planning options considered, along with the associated costs, are included in Table 1 below. These costs exclude contingency but include an allowance for overheads and finance charges. The cost estimates have an accuracy of $\pm 30\%$.

Option	Option Title	Capital cost (M)	Deferred Capital Cost (M)
1	Replace all 500kV GIS with AIS	\$70.80	N/A
2	Replace all 500kV GIS with Indoor GIS	\$146.88	N/A
3	Staged replacement of GIS with AIS	\$19.46	\$51.34
4	Staged replacement of GIS with GIS	\$53.27	\$93.61

Table 1 - Estimated Capital Costs

[C-I-C]
DESIGN MANAGER

2. INTRODUCTION

AusNet Services engaged APD Engineering to prepare a project scopes and estimates relating to options for replacement of primary and secondary equipment at South Morang Terminal Station (SMTS) for inclusion in AusNet Services' 2022 – 2027 Transmission Revenue Reset.

AusNet Services has identified that the existing 500kV outdoor GIS equipment is in poor condition and presents a risk of failure. AusNet Services has provided a functional scope outlining the equipment condition assessments and outlining possible options for replacement.

It has been agreed with AusNet Services that APD Engineering will provide high level estimates for replacement projects only. Where a refurbishment option is presented in the functional requirements, AusNet Services will estimate the cost of refurbishment.

Scoping for the 500kV outdoor GIS primary and associated secondary equipment, along with planning options for consideration have been prepared as per as per reference [1] – South Morang Terminal Station (SMTS) 500kV GIS Replacement Project TD-0008025.

3. LIMITATIONS

In preparing this report, APD Engineering has relied on information provided by AusNet Services, including (but not limited to):

1. Site drawings and documentation outlining the existing equipment on site;
2. Condition assessments and functional scopes identifying poor condition primary and secondary assets for replacement prepared by AusNet Services, along with supporting information to allow the development of the scopes and estimates;
3. A top down estimating spreadsheet provided by AusNet Services to calculate the capital costs associated with each project;
4. Unit costs for major items of plant and equipment, labour costs and other costs assumptions provided by AusNet Services as part of the top down estimating spreadsheet.

4. ASSUMPTIONS

1. It has been assumed that the F3 500/220kV transformer has been established at SMTS.
2. Minimal information was available within the AusNet Services estimating spreadsheet for communications equipment. As such, no allowance has been made for telecommunications replacement.
3. It is assumed that, where required, the existing 415 VAC and 250VDC equipment can be modified as part of the project. Replacement of the full 415V AC/ 250VDC or 48VDC distribution boards and batteries has not been considered.
4. It is assumed that SCIMS hardware can be modified as part of the project. Full replacement of the RTU/SCIMS alarm modification or panel replacement has not been considered.
5. Allowance has been made to replace all Condition 4 and Condition 5 relays, including relays older than 9 years under Condition 2 and 3.

5. OPTION 1 – REPLACE ALL 500KV GIS WITH AIS

5.1. OUTLINE OF PROJECT

This option would result in the existing 500kV outdoor GIS equipment replaced with a modern outdoor AIS solution.

APD Engineering has confirmed that the existing rack structures are spaced to allow the installation of an AIS solution. These rack structures, however, have been designed for the GIS solution. This has allowed the rack structures to be lower in height and, as such, they are not sufficiently high enough to allow the installation of 500kV AIS switchgear and will need to be replaced.

Replacing the rack structures will require outages of adjacent 500kV equipment for proximity (allowing for plant, equipment and construction crews to work safely).

APD Engineering has identified a possible construction sequence that will allow temporary connections between the new AIS and the existing GIS. This staging is shown in Appendix B.1 & B.2.

APD Engineering has identified that the F2 500/330kV transformer project must be completed before the existing GIS can be demolished. The control room must also be

relocated to facilitate an AIS connection to the F2 transformer with the establishment of the F3 transformer.

Figure 1 shows the final SLD at the completion of the project. Figure 2 shows the possible final arrangements on site at the completion of the project.

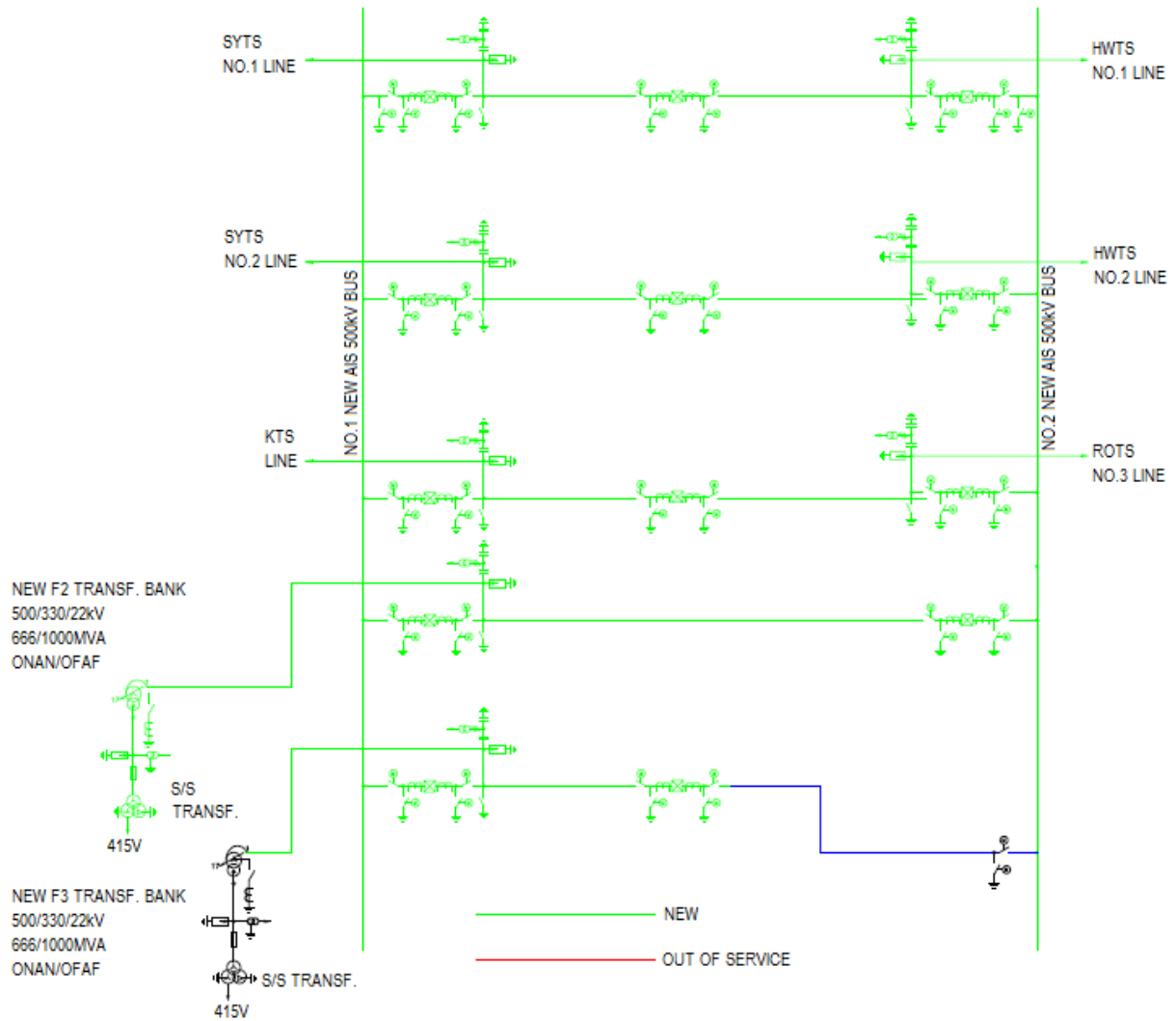

Figure 1 - SMTS 500kV SLD

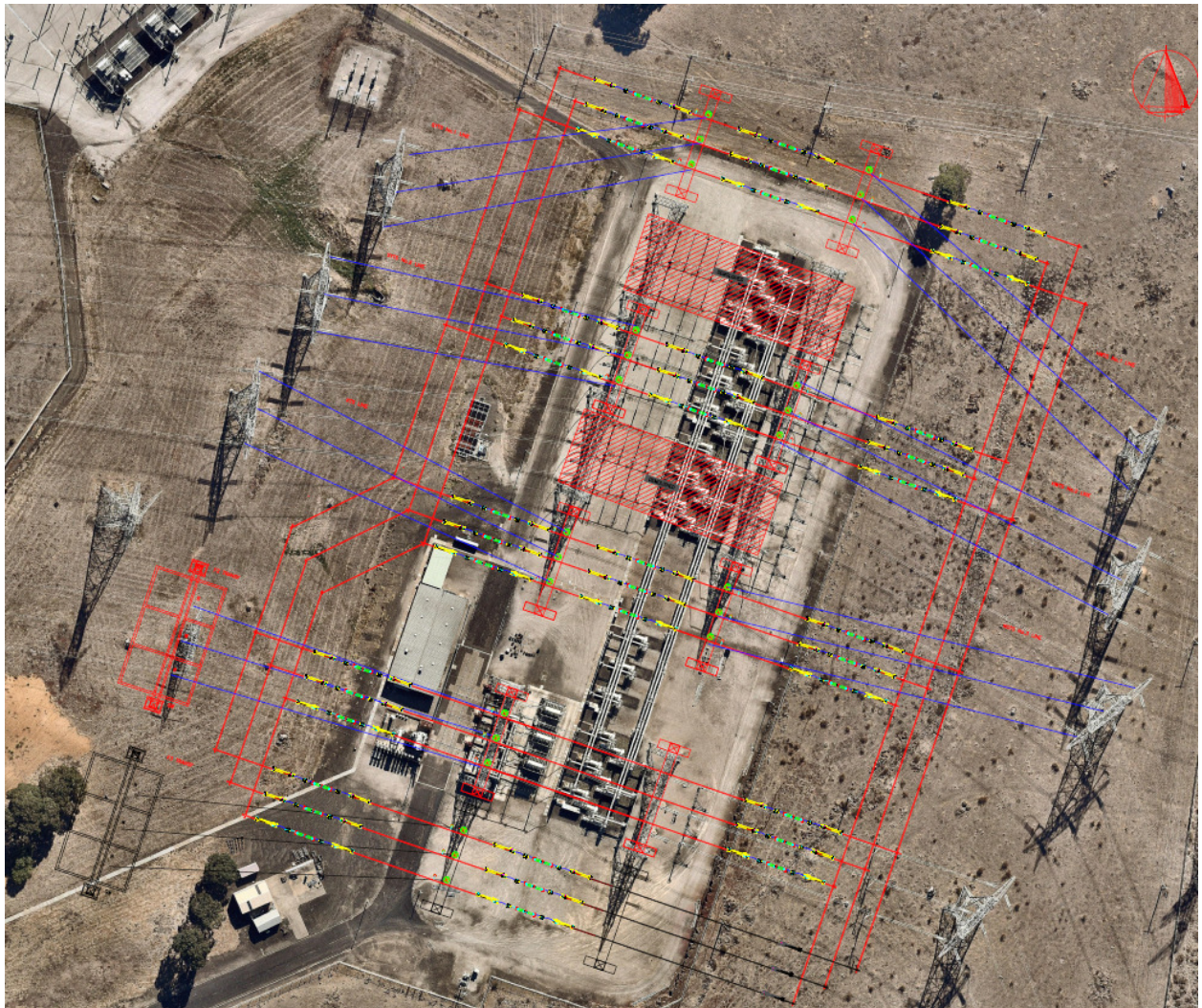

Figure 2 - SMTS 500kV SWITCHYARD POSSIBLE GENERAL ARRANGEMENT

5.2. OPTION 1 – PLANNING ESTIMATE

Based on the scope in Appendix B.1 and B.2, this option has been estimated using the AusNet Services estimating spreadsheet at a total capital cost of \$70.80M ($\pm 30\%$). This cost excludes any management contingency.

6. OPTION 2 – REPLACE ALL 500KV GIS WITH INDOOR GIS

6.1. OUTLINE OF PROJECT

This option would result in the replacement of the existing diameters of 500kV outdoor GIS with modern indoor equivalents.

AusNet Services has identified that the existing 500kV outdoor GIS equipment is in poor condition. To replace this equipment with modern 500kV indoor GIS would require:

1. Construction of a new 500kV GIS building;
2. Installation and commissioning of five new 500kV GIS diameters;
3. Transition of the existing 500kV overhead lines into the building
4. Transition of the existing overhead 500/330kV transformer connection into the building.

The existing rack structures would be retained to maintain the ability to bypass the site for operational reasons.

6.2. OPTION 2 – PLANNING ESTIMATE

Based on the scope in Appendix A.1, A.2, and C.1, this option has been estimated using the AusNet Services estimating spreadsheet at a total capital cost of \$146.88M ($\pm 30\%$). This cost excludes any management contingency.

7. OPTION 3 – STAGED REPLACEMENT OF 500KV GIS WITH AIS

7.1. OUTLINE OF PROJECT

This option would result in the separation of the replacement of the outdoor 500kV GIS equipment with AIS into two separate projects undertaken independently.

The initial replacement project would result in the construction of:

- one new breaker and one- half bay at the northern end of the existing switchyard;
- relocation of the HWTS – SMTS No 1 Line and the SMTS – SYTS No 1 Line;
- new AIS 500kV busbars;
- new bus side breakers connecting the HWTS – SMTS No 2 Line and the SMTS – SYTS No 2 Lines to the AIS busbars.

A future project would then replace all of the remaining equipment.

7.2. OPTION 3 – PLANNING ESTIMATE

Based on the scope in Appendix B.3 and B.4, this option has been estimated using the AusNet Services estimating spreadsheet at a total capital cost of \$19.46M ($\pm 30\%$). This cost excludes any management contingency.

The future project to replace the remaining equipment has been estimated using the AusNet Services estimating spreadsheet at a total capital cost of \$51.34M

8. OPTION 4 – STAGED REPLACEMENT OF 500KV GIS WITH GIS

8.1. OUTLINE OF PROJECT

This option would result in the separation of the replacement of the outdoor 500kV GIS equipment with modern indoor GIS into two separate projects undertaken independently.

The initial replacement project would result in the construction of:

1. Construction of a new 500kV GIS building;
2. Installation and commissioning of two new 500kV GIS diameters;
3. Transition of one of the existing 500kV overhead lines into the building;
4. Temporary Connection of the existing outdoor GIS to the indoor GIS

A future project would then replace all of the remaining equipment.

8.2. OPTION 4 – PLANNING ESTIMATE

Based on the scope in Appendix A.3, A.4 and C.2, this option has been estimated using the AusNet Services estimating spreadsheet at a total capital cost of \$53.27M ($\pm 30\%$). This cost excludes any management contingency.

The future project to replace the remaining equipment has been estimated using the AusNet Services estimating spreadsheet at a total capital cost of \$93.61M

9. REFERENCES

The following document were applied in preparation of this report.

TYPE	OWNER	TITLE
Document	AusNet	South Morang Terminal Station (SMTS) 500kV GIS Replacement Project TD-0008025
Document	AusNet	Top-down Transmission Estimate for Option Selection Rev 2.7
Document	AusNet	Relays Condition Score Status as off 07.05.2019
Drawing	AusNet	South Morang Terminal Station 66kV, 220kV and 500kV Single Line Diagram – T14/31/157
Drawing	AusNet	South Morang Terminal Station 500kV Switchyard Layout – T2/752/251
Drawing	AusNet	South Morang Terminal Station 500kV Switchyard Section Sheet 1 – T2/752/252
Drawing	AusNet	South Morang Terminal Station 500kV Switchyard Section Sheet 2 – T2/752/253
Drawing	AusNet	South Morang Terminal Station 500kV Switchyard Section Sheet 3 – T2/752/254
Drawing	AusNet	South Morang Terminal Station 500kV Switchyard Section Sheet 4 – T2/752/653

APPENDIX A.

500kV Outdoor GIS primary and secondary assets replacement works within SMTS includes the following primary and secondary assets replacement (GIS to GIS).

APPENDIX A.1.

Scope to replace all poor condition 500kV Outdoor GIS assets with 500kV Indoor GIS

500kV Bay	Activity	Description (Primary Equipment)
Bay A	Remove	Existing GIS - Spare BBC 500kV GIS CB Pole
		Existing GIS - SYTS No.1 500kV Line No.1 Bus CB
		Existing GIS - HWTS No.1 Line/ SYTS No.1 Line 500kV CB
		Existing GIS - HWTS No.1 500kV Line No.2 Bus CB
		Existing GIS - SYTS No.1 500kV Line No.1 Bus CB Line Side CT
		Existing GIS - SYTS No.1 500kV Line No.1 Bus CB Bus Side CT
		Existing GIS - HWTS No.1 Line/ SYTS No.1 Line 500kV CB SYTS Line Side CT
		Existing GIS - HWTS No.1 Line/ SYTS No.1 Line 500kV CB HWTS Line Side CT
		Existing GIS - HWTS No.1 500kV Line No.2 Bus CB Line Side CT
		Existing GIS - HWTS No.1 500kV Line No.2 Bus CB Bus Side CT
		Existing GIS - SYTS No.1 500kV Line No.1 Bus CB Line Side E/SW

		Existing GIS - SYTS No.1 500kV Line No.1 Bus CB Bus Side E/SW
		Existing GIS - SYTS No.1 Line 500kV E/SW
		Existing GIS - HWTS No.1 500kV Line No.2 Bus CB Line Side E/SW
		Existing GIS - HWTS No.1 500kV Line No.2 Bus CB Bus Side E/SW
		Existing GIS - HWTS No.1 Line/ SYTS No.1 Line 500kV CB SYTS Line Side E/SW
		Existing GIS - HWTS No.1 Line/ SYTS No.1 Line 500kV CB HWTS Line Side E/SW
		Existing GIS - HWTS No.1 Line 500kV E/SW
		Existing GIS - SYTS No.1 500kV Line No.1 Bus CB Line Side ROI
		Existing GIS - SYTS No.1 500kV Line No.1 Bus CB Bus Side ROI
		Existing GIS - HWTS No.1 500kV Line No.2 Bus CB Line Side ROI
		Existing GIS - HWTS No.1 500kV Line No.2 Bus CB Bus Side ROI
		Existing GIS - HWTS No.1 Line/ SYTS No.1 Line 500kV CB SYTS Line Side ROI
		Existing GIS - HWTS No.1 Line/ SYTS No.1 Line 500kV CB HWTS Line Side ROI
Bay B	Remove	Existing GIS - SYTS No.2 500kV Line No.1 Bus CB
		Existing GIS - HWTS No.2 Line/ SYTS No.2 Line 500kV CB
		Existing GIS - HWTS No.2 500kV Line No.2 Bus CB
		Existing GIS - SYTS No.2 500kV Line No.1 Bus CB Line Side CT

	Existing GIS - SYTS No.2 500kV Line No.1 Bus CB Bus Side CT
	Existing GIS - HWTS No.2 Line/ SYTS No.2 Line 500kV CB SYTS Line Side CT
	Existing GIS - HWTS No.2 Line/ SYTS No.2 Line 500kV CB HWTS Line Side CT
	Existing GIS - HWTS No.2 500kV Line No.2 Bus CB Line Side CT
	Existing GIS - HWTS No.2 500kV Line No.2 Bus CB Bus Side CT
	Existing GIS - SYTS No.2 500kV Line No.1 Bus CB Line Side E/SW
	Existing GIS - SYTS No.2 500kV Line No.1 Bus CB Bus Side E/SW
	Existing GIS - SYTS No.2 Line 500kV E/SW
	Existing GIS - HWTS No.2 500kV Line No.2 Bus CB Line Side E/SW
	Existing GIS - HWTS No.2 500kV Line No.2 Bus CB Bus Side E/SW
	Existing GIS - HWTS No.2 Line SYTS No.2 Line 500kV CB SYTS Line Side E/SW
	Existing GIS - HWTS No.2 Line/ SYTS No.2 Line 500kV CB HWTS Line Side E/SW
	Existing GIS - HWTS No.2 Line 500kV E/SW
	Existing GIS - SYTS No.2 500kV Line No.1 Bus CB Line Side ROI
	Existing GIS - SYTS No.2 500kV Line No.1 Bus CB Bus Side ROI
	Existing GIS - HWTS No.2 500kV Line No.2 Bus CB Line Side ROI

		Existing GIS - HWTS No.2 500kV Line No.2 Bus CB Bus Side ROI
		Existing GIS - HWTS No.2 Line/ SYTS No.2 Line 500kV CB SYTS Line Side ROI
		Existing GIS - HWTS No.2 Line/ SYTS No.2 Line 500kV CB HWTS Line Side ROI
Bay C	Remove	Existing GIS - KTS 500kV Line No.1 Bus CB
		Existing GIS - ROTS No.3 Line/ KTS Line 500kV CB
		Existing GIS - ROTS No.3 500kV Line No.2 Bus CB
		Existing GIS - KTS 500kV Line No.1 Bus CB Line Side CT
		Existing GIS - KTS 500kV Line No.1 Bus CB Bus Side CT
		Existing GIS - ROTS No.3 Line/ KTS Line 500kV CB KTS Line Side CT
		Existing GIS - ROTS No.3 Line/ KTS Line 500kV CB ROTS Line Side CT
		Existing GIS - ROTS No.3 500kV Line No.2 Bus CB Line Side CT
		Existing GIS - ROTS No.3 500kV Line No.2 Bus CB Bus Side CT
		Existing GIS - KTS 500kV Line No.1 Bus CB Line Side E/SW
		Existing GIS - KTS 500kV Line No.1 Bus CB Bus Side E/SW
		Existing GIS - KTS 500kV Line E/SW
		Existing GIS - ROTS No.3 500kV Line No.2 Bus CB Line Side E/SW
		Existing GIS - ROTS No.3 500kV Line No.2 Bus CB Bus Side E/SW
		Existing GIS - ROTS No.3 Line/ KTS Line 500kV CB KTS Line Side E/SW

		Existing GIS - ROTS No.3 Line/ KTS Line 500kV CB ROTS Line Side E/SW
		Existing GIS - ROTS No.3 Line 500kV E/SW
		Existing GIS - KTS 500kV Line No.1 Bus CB Line Side ROI
		Existing GIS - KTS 500kV Line No.1 Bus CB Bus Side ROI
		Existing GIS - ROTS No.3 500kV Line No.2 Bus CB Line Side ROI
		Existing GIS - ROTS No.3 500kV Line No.2 Bus CB Bus Side ROI
		Existing GIS - ROTS No.3 Line/ KTS Line 500kV CB KTS Line Side ROI
		Existing GIS - ROTS No.3 Line/ KTS Line 500kV CB ROTS Line Side ROI
Bay E	Remove	Existing GIS - Future F1 TRANS 500kV CB
		Existing GIS - Future F1 TRANS 500kV CB Bus Side CT
		Existing GIS - Future F1 TRANS 500kV CB TRANS Side CT
		Existing GIS - Future F1 TRANS 500kV CB Bus Side E/SW
		Existing GIS - Future F1 TRANS 500kV CB TRANS Side E/SW
		Existing GIS - Future F1 TRANS 500kV E/SW
		Existing GIS - Future F1 TRANS 500kV CB Bus Side ROI
		Existing GIS - Future F1 TRANS 500kV CB TRANS Side ROI
Bay F	Remove	Existing GIS - F2 TRANS No.1 Bus 500kV CB
		Existing GIS - F2 TRANS Non Auto 500kV CB
		Existing GIS - F2 TRANS No.2 Bus 500kV CB

		Existing GIS - F2 TRANS No.1 Bus 500kV CB Bus Side CT
		Existing GIS - F2 TRANS No.1 Bus 500kV CB TRANS Side CT
		Existing GIS - F2 TRANS Non Auto 500kV CB TRANS Side CT
		Existing GIS - F2 TRANS Non Auto 500kV CB Line Side CT
		Existing GIS - F2 TRANS No.2 Bus 500kV CB Line Side CT
		Existing GIS - F2 TRANS No.2 Bus 500kV CB Bus Side CT
		Existing GIS - F2 500/330kV TRANS 500kV VT "R" Phase
		Existing GIS - F2 500/330kV TRANS 500kV VT "W" Phase
		Existing GIS - F2 500/330kV TRANS 500kV VT "B" Phase
		Existing GIS - F2 TRANS No.1 Bus 500kV CB Bus Side E/SW
		Existing GIS - F2 TRANS No.1 Bus 500kV CB TRANS Side E/SW
		Existing GIS - F2 TRANS Non Auto 500kV CB TRANS Side E/SW
		Existing GIS - F2 TRANS Non Auto 500kV CB Line Side E/SW
		Existing GIS - F2 TRANS No.2 Bus 500kV CB Line Side E/SW
		Existing GIS - F2 TRANS No.2 Bus 500kV CB Bus Side E/SW
		Existing GIS - F2 TRANS 500kV E/SW
		Existing GIS - F2 TRANS No.1 Bus 500kV CB Bus Side ROI
		Existing GIS - F2 TRANS No.1 Bus 500kV CB TRANS Side ROI
		Existing GIS - F2 TRANS Non Auto 500kV CB Line Side E/SW

		Existing GIS - F2 TRANS Non Auto 500kV CB TRANS Side ROI
		Existing GIS - F2 TRANS Non Auto 500kV CB Line Side ROI
		Existing GIS - F2 TRANS No.2 Bus 500kV CB Line Side ROI
		Existing GIS - F2 TRANS No.2 Bus 500kV CB Bus Side ROI
		Existing GIS - No.1 500kV Bus E/SW
		Existing GIS - No.2 500kV Bus E/SW

New works for indoor GIS:

1. Construction of a new 500kV GIS building (including overhead crane, internal lighting, internal earthing system and fire protection system);
2. Installation and commissioning of five new 500kV GIS diameters (including supply, installation, site testing, commissioning, GIS local control cubicles and secondary systems);
3. Five x 3 phase Surge Arrestors including footings and earthing; and
4. Transition of the existing 500kV overhead lines into the building.

APPENDIX A.2.

Scope to replace all poor condition 500kV Outdoor GIS assets with 500kV Indoor GIS

500kV Bay	Activity	Description (Secondary Equipment)
Bay A	Remove	SYTS 1 Digital Current Differential Relay
		SYTS 1 Digital Current Differential Relay
		SYTS 1 Backup Negative Sequence Overcurrent
		SYTS 1 Backup Remote Trip Interlock Relay
		SYTS 1 1B X CB Fail & Control (CBM)
		SYTS 1 CB Sensitive Current Check Relay (CBM)
		HWTS 1/ SYTS 1 X CB Fail & Control (CBM)
		HWTS 1/ SYTS 1 CB Sensitive Current Check (CBM)
		Bay A CBF Overcurrent Relay (CBM)
		HWTS 1 Digital Current Differential Relay
		HWTS 1 Digital Current Differential Relay
		HWTS 1 Over Voltage Relay
		HWTS 1 2B X CB Fail & Control (CBM)
	HWTS 1 CB Sensitive Current Check (CBM)	
	Install	<ul style="list-style-type: none"> - Install new one-off SYTS No.1 Line No.1 Bus CB X & Y CB Management (CB Fail & Control) Scheme
		<ul style="list-style-type: none"> - Install new one-off SYTS No.1 500kV X Protection Scheme
		<ul style="list-style-type: none"> - Install new one-off SYTS No.1 500kV Y Protection Scheme
		<ul style="list-style-type: none"> - One-off SYTS No.1 500kV X Protection Scheme to remote end.
		<ul style="list-style-type: none"> - One-off SYTS No.1 500kV Y Protection Scheme to remote end.

		<ul style="list-style-type: none"> - Install new one-off SYTS NO.1/ HWTS No.1 Line CB X & Y CB Management (CB Fail & Control) Scheme
		<ul style="list-style-type: none"> - Install new one-off HWTS No.1 Line No.2 Bus CB X & Y CB Management (CB Fail & Control) Scheme
		<ul style="list-style-type: none"> - Install new one-off HWTS No.1 500kV X Protection Scheme
		<ul style="list-style-type: none"> - Install new one-off HWTS No.1 500kV Y Protection Scheme
		<ul style="list-style-type: none"> - Install new one-off HWTS No.1 500kV X Protection Scheme to remote end.
		<ul style="list-style-type: none"> - Install new one-off HWTS No.1 500kV Y Protection Scheme to remote end.
		<ul style="list-style-type: none"> - Install new three-off Interface Termination Cubicles Bay A
Bay B	Remove	SYTS 2 Digital Current Differential Relay
		SYTS 2 Digital Current Differential Relay
		SYTS 2 1B X CB Fail & Control (CBM)
		SYTS 2 1B CB Fail Relay (CBM)
		HWTS 2/SYTS 2 X CB Fail & Control (CBM)
		HWTS 2/SYTS 2 CB Fail Relay (CBM)
		HWTS 2 Digital Current Differential Relay
		HWTS 2 Digital Current Differential Relay
		HWTS 2 Over Voltage Relay
		HWTS 2 2B X CB Fail & Control (CBM)
		HWTS 2 2B CB Fail Relay (CBM)
	Install	<ul style="list-style-type: none"> - Install new one-off SYTS No.2 Line No.1 Bus CB X & Y CB Management (CB Fail & Control) Scheme
		<ul style="list-style-type: none"> - Install new one-off SYTS No.2 500kV X Protection Scheme
		<ul style="list-style-type: none"> - Install new one-off SYTS No.2 500kV Y Protection Scheme

		- One-off SYTS No.2 500kV X Protection Scheme to remote end.
		- One-off SYTS No.2 500kV Y Protection Scheme to remote end.
		- Install new one-off SYTS No.2/ HWTS No.2 Line CB X & Y CB Management (CB Fail & Control) Scheme
		- Install new one-off HWTS No.2 Line No.2 Bus CB X & Y CB Management (CB Fail & Control) Scheme
		- Install new one-off HWTS No.2 500kV X Protection Scheme
		- Install new one-off HWTS No.2 500kV Y Protection Scheme
		- Install new one-off HWTS No.2 500kV X Protection Scheme to remote end.
		- Install new one-off HWTS No.2 500kV Y Protection Scheme to remote end.
		- Install new three-off Interface Termination Cubicles Bay B
Bay C	Remove	KTS X Digital Current Differential Relay
		KTS Y Digital Current Diff/ Distance Relay
		KTS CB Fail Relay (CBM)
		ROTS 3/KTS CB Fail Relay (CBM)
		ROTS 3 X Digital Current Diff & Remote
		ROTS 3 Y Digital Current Differential Relay
		ROTS 3 Y Digital Current Diff Relay
		ROTS 3 Y Digital Current Differential Relay
		ROTS 3 Y Voltage Relay
		ROTS 3 Y Voltage Relay
		ROTS 3 Y Voltage Relay
		ROTS 3 Y Voltage Relay
		ROTS 3 Y Voltage Relay

		ROTS 3 CB Fail Relay (CBM)
	Install	- Install new one-off KTS Line No.1 Bus CB X & Y CB Management (CB Fail & Control) Scheme
		- Install new one-off KTS LINE 500kV X Protection Scheme
		- Install new one-off KTS LINE 500kV Y Protection Scheme
		- Install new one-off KTS LINE 500kV X Protection Scheme to remote end.
		- Install new one-off KTS LINE 500kV Y Protection Scheme to remote end.
		- Install new one-off KTS/ ROTS NO.3 Line CB X & Y CB Management (CB Fail & Control) Scheme
		- Install new one-off ROTS NO.3 Line No.2 Bus CB X & Y CB Management (CB Fail & Control) Scheme
		- Install new one-off ROTS NO.3 500kV X Protection Scheme
		- Install new one-off ROTS No.3 500kV Y Protection Scheme
		- Install new one-off ROTS NO.3 500kV X Protection Scheme to remote end.
		- Install new one-off ROTS No.3 500kV Y Protection Scheme to remote end.
		- Install new three-off Interface Termination Cubicles Bay C
Common Bays	Remove	#1 500 X Differential Relay
		#1 500 X Differential Relay
		#1 500 X Differential Relay
		#1 500 Y Differential Relay
		#1 500 Y Differential Relay
		#1 500 Y Differential Relay

		#2 500 X Differential Relay
		#2 500 X Differential Relay
		#2 500 X Differential Relay
		#2 500 Y Differential Relay
		#2 500 Y Differential Relay
		#2 500 Y Differential Relay
		500kV Sync and Bus POT Select
		500kV CB Sync Check
		500kV CB Control & Sync Check
		500kV Dummy CB POT Select
		SYTS 1 & 2 500kV Line POT Select
	Install (Part 1)	- Install new one off No.1 500kV Bus X High Impedance Bus Protection Scheme No. T24
		- Install new one off No.1 500kV Bus Y High Impedance Bus Protection Scheme No. T25
		- Install new one off No.2 500kV Bus X High Impedance Bus Protection Scheme No. T26
		- Install new one off No.2 500kV Bus Y High Impedance Bus Protection Scheme No. T27
		- Install new one off 500kV Bus Potential Selection Panel

APPENDIX A.3.

Scope to replace one diameter of 500kV GIS with AIS - 500kV AIS Bay Extension

500kV Bay	Activity	Description (Primary Equipment)
Bay A	Remove	Existing GIS - Spare BBC 500kV GIS CB Pole
		Existing GIS - SYTS No.1 500kV Line No.1 Bus CB
		Existing GIS - HWTS No.1 Line/ SYTS No.1 Line 500kV CB
		Existing GIS - HWTS No.1 500kV Line No.2 Bus CB
		Existing GIS - SYTS No.1 500kV Line No.1 Bus CB Line Side CT
		Existing GIS - SYTS No.1 500kV Line No.1 Bus CB Bus Side CT
		Existing GIS - HWTS No.1 Line/ SYTS No.1 Line 500kV CB SYTS Line Side CT
		Existing GIS - HWTS No.1 Line/ SYTS No.1 Line 500kV CB HWTS Line Side CT
		Existing GIS - HWTS No.1 500kV Line No.2 Bus CB Line Side CT
		Existing GIS - HWTS No.1 500kV Line No.2 Bus CB Bus Side CT
		Existing GIS - SYTS No.1 500kV Line No.1 Bus CB Line Side E/SW
		Existing GIS - SYTS No.1 500kV Line No.1 Bus CB Bus Side E/SW
		Existing GIS - SYTS No.1 Line 500kV E/SW
Existing GIS - HWTS No.1 500kV Line No.2 Bus CB Line Side E/SW		

	Existing GIS - HWTS No.1 500kV Line No.2 Bus CB Bus Side E/SW
	Existing GIS - HWTS No.1 Line/ SYTS No.1 Line 500kV CB SYTS Line Side E/SW
	Existing GIS - HWTS No.1 Line/ SYTS No.1 Line 500kV CB HWTS Line Side E/SW
	Existing GIS - HWTS No.1 Line 500kV E/SW
	Existing GIS - SYTS No.1 500kV Line No.1 Bus CB Line Side ROI
	Existing GIS - SYTS No.1 500kV Line No.1 Bus CB Bus Side ROI
	Existing GIS - HWTS No.1 500kV Line No.2 Bus CB Line Side ROI
	Existing GIS - HWTS No.1 500kV Line No.2 Bus CB Bus Side ROI
	Existing GIS - HWTS No.1 Line/ SYTS No.1 Line 500kV CB SYTS Line Side ROI
	Existing GIS - HWTS No.1 Line/ SYTS No.1 Line 500kV CB HWTS Line Side ROI

New works for indoor GIS:

1. Construction of a new 500kV GIS building (including overhead crane, internal lighting, internal earthing system and fire protection system);
2. Installation and commissioning one new 500kV GIS diameters (including supply, installation, site testing, commissioning, GIS local control cubicles and secondary systems);
3. Five x 3 phase Surge Arrestors including footings and earthing; and
4. Transition of the existing 500kV overhead lines into the building.

APPENDIX A.4.

Scope to replace one diameter of 500kV GIS with AIS - 500kV AIS Bay Extension

500kV Bay	Activity	Description (Secondary Equipment)
Bay A	Remove	SYTS 1 Digital Current Differential Relay
		SYTS 1 Digital Current Differential Relay
		SYTS 1 Backup Negative Sequence Overcurrent
		SYTS 1 Backup Remote Trip Interlock Relay
		SYTS 1 1B X CB Fail & Control (CBM)
		SYTS 1 CB Sensitive Current Check Relay (CBM)
		HWTS 1/ SYTS 1 X CB Fail & Control (CBM)
		HWTS 1/ SYTS 1 CB Sensitive Current Check (CBM)
		Bay A CBF Overcurrent Relay (CBM)
		HWTS 1 Digital Current Differential Relay
		HWTS 1 Digital Current Differential Relay
		HWTS 1 Over Voltage Relay
		HWTS 1 2B X CB Fail & Control (CBM)
		HWTS 1 CB Sensitive Current Check (CBM)
	Install	<ul style="list-style-type: none"> - Install new one-off SYTS No.1 Line No.1 Bus CB X & Y CB Management (CB Fail & Control) Scheme
		<ul style="list-style-type: none"> - Install new one-off SYTS No.1 500kV X Protection Scheme
		<ul style="list-style-type: none"> - Install new one-off SYTS No.1 500kV Y Protection Scheme
		<ul style="list-style-type: none"> - One-off SYTS No.1 500kV X Protection Scheme to remote end.
		<ul style="list-style-type: none"> - One-off SYTS No.1 500kV Y Protection Scheme to remote end.
<ul style="list-style-type: none"> - Install new one-off SYTS NO.1/ HWTS No.1 Line CB X & Y CB Management (CB Fail & Control) Scheme 		

		<ul style="list-style-type: none">- Install new one-off HWTS No.1 Line No.2 Bus CB X & Y CB Management (CB Fail & Control) Scheme
		<ul style="list-style-type: none">- Install new one-off HWTS No.1 500kV X Protection Scheme
		<ul style="list-style-type: none">- Install new one-off HWTS No.1 500kV Y Protection Scheme
		<ul style="list-style-type: none">- Install new one-off HWTS No.1 500kV X Protection Scheme to remote end.
		<ul style="list-style-type: none">- Install new one-off HWTS No.1 500kV Y Protection Scheme to remote end.
		<ul style="list-style-type: none">- Install new three-off Interface Termination Cubicles Bay A

APPENDIX B.

500kV Outdoor GIS primary and secondary assets replacement works within SMTS includes the following primary and secondary assets replacement (GIS to AIS).

APPENDIX B.1.

Scope to replace all poor condition 500kV Outdoor GIS assets with 500kV AIS as per Figure 2 (primary equipment) – Option 2

500kV Bay	Activity	Description (Primary Equipment)
Bay A	Remove	Existing GIS - Spare BBC 500kV GIS CB Pole
		Existing GIS - SYTS No.1 500kV Line No.1 Bus CB
		Existing GIS - HWTS No.1 Line/ SYTS No.1 Line 500kV CB
		Existing GIS - HWTS No.1 500kV Line No.2 Bus CB
		Existing GIS - SYTS No.1 500kV Line No.1 Bus CB Line Side CT
		Existing GIS - SYTS No.1 500kV Line No.1 Bus CB Bus Side CT
		Existing GIS - HWTS No.1 Line/ SYTS No.1 Line 500kV CB SYTS Line Side CT
		Existing GIS - HWTS No.1 Line/ SYTS No.1 Line 500kV CB HWTS Line Side CT
		Existing GIS - HWTS No.1 500kV Line No.2 Bus CB Line Side CT
		Existing GIS - HWTS No.1 500kV Line No.2 Bus CB Bus Side CT
		Existing GIS - SYTS No.1 500kV Line No.1 Bus CB Line Side E/SW

		Existing GIS - SYTS No.1 500kV Line No.1 Bus CB Bus Side E/SW
		Existing GIS - SYTS No.1 Line 500kV E/SW
		Existing GIS - HWTS No.1 500kV Line No.2 Bus CB Line Side E/SW
		Existing GIS - HWTS No.1 500kV Line No.2 Bus CB Bus Side E/SW
		Existing GIS - HWTS No.1 Line/ SYTS No.1 Line 500kV CB SYTS Line Side E/SW
		Existing GIS - HWTS No.1 Line/ SYTS No.1 Line 500kV CB HWTS Line Side E/SW
		Existing GIS - HWTS No.1 Line 500kV E/SW
		Existing GIS - SYTS No.1 500kV Line No.1 Bus CB Line Side ROI
		Existing GIS - SYTS No.1 500kV Line No.1 Bus CB Bus Side ROI
		Existing GIS - HWTS No.1 500kV Line No.2 Bus CB Line Side ROI
		Existing GIS - HWTS No.1 500kV Line No.2 Bus CB Bus Side ROI
		Existing GIS - HWTS No.1 Line/ SYTS No.1 Line 500kV CB SYTS Line Side ROI
		Existing GIS - HWTS No.1 Line/ SYTS No.1 Line 500kV CB HWTS Line Side ROI
	Install	New SYTS No.1 500kV Line No.1 Bus CB
		New HWTS No.1 Line/ SYTS No.1 Line 500kV CB
		New HWTS No.1 500kV Line No.2 Bus CB
		New SYTS No.1 500kV Line No.1 Bus CB Line Side CT - Including 3 x off Single Phase Post Type 500kV CT

	<p>New HWTS No.1 Line/ SYTS No.1 Line 500kV CB SYTS Line Side CT</p> <ul style="list-style-type: none"> - Including 3 x off Single Phase Post Type 500kV CT
	<p>New HWTS No.1 500kV Line No.2 Bus CB Line Side CT</p> <ul style="list-style-type: none"> - Including 3 x off Single Phase Post Type 500kV CT
	<p>New SYTS No.1 500kV Line No.1 Bus CB Line Side ROI</p> <ul style="list-style-type: none"> - Including 2 x integrated earth switch
	<p>New SYTS No.1 500kV Line No.1 Bus CB Bus Side ROI</p> <ul style="list-style-type: none"> - Including 2 x integrated earth switch
	<p>New HWTS No.1 500kV Line No.2 Bus CB Line Side</p> <ul style="list-style-type: none"> - Including 2 x integrated earth switch
	<p>New HWTS No.1 500kV Line No.2 Bus CB Bus Side ROI</p> <ul style="list-style-type: none"> - Including 2 x integrated earth switch
	<p>New HWTS No.1 Line/ SYTS No.1 Line 500kV CB SYTS Line Side ROI</p> <ul style="list-style-type: none"> - Including 1 x integrated earth switch
	<p>New HWTS No.1 Line/ SYTS No.1 Line 500kV CB HWTS Line Side ROI</p> <ul style="list-style-type: none"> - Including 1 x integrated earth switch
	<ul style="list-style-type: none"> - Install six (6) 500kV Surge Arresters
	<ul style="list-style-type: none"> - Install Nine (9) 500kV Post Insulators
	<ul style="list-style-type: none"> - Install three (3) CT Bay Marshalling Boxes
	<ul style="list-style-type: none"> - Install three (2) VT Bay Marshalling Boxes
	<ul style="list-style-type: none"> - Install three (3) Switchyard GPO and Lighting Marshalling Boxes
	<ul style="list-style-type: none"> - Install one (1) No.1 500kV Bus X & Y High Impedance Bus Protection CT Summation Box
	<ul style="list-style-type: none"> - Install one (1) No.2 500kV Bus X & Y High Impedance Bus Protection CT Summation Box

		- Install new three Interface Termination Cubicles Bay
Bay B	Remove	Existing GIS - SYTS No.2 500kV Line No.1 Bus CB
		Existing GIS - HWTS No.2 Line/ SYTS No.2 Line 500kV CB
		Existing GIS - HWTS No.2 500kV Line No.2 Bus CB
		Existing GIS - SYTS No.2 500kV Line No.1 Bus CB Line Side CT
		Existing GIS - SYTS No.2 500kV Line No.1 Bus CB Bus Side CT
		Existing GIS - HWTS No.2 Line/ SYTS No.2 Line 500kV CB SYTS Line Side CT
		Existing GIS - HWTS No.2 Line/ SYTS No.2 Line 500kV CB HWTS Line Side CT
		Existing GIS - HWTS No.2 500kV Line No.2 Bus CB Line Side CT
		Existing GIS - HWTS No.2 500kV Line No.2 Bus CB Bus Side CT
		Existing GIS - SYTS No.2 500kV Line No.1 Bus CB Line Side E/SW
		Existing GIS - SYTS No.2 500kV Line No.1 Bus CB Bus Side E/SW
		Existing GIS - SYTS No.2 Line 500kV E/SW
		Existing GIS - HWTS No.2 500kV Line No.2 Bus CB Line Side E/SW
		Existing GIS - HWTS No.2 500kV Line No.2 Bus CB Bus Side E/SW
		Existing GIS - HWTS No.2 Line SYTS No.2 Line 500kV CB SYTS Line Side E/SW
		Existing GIS - HWTS No.2 Line/ SYTS No.2 Line 500kV CB HWTS Line Side E/SW
		Existing GIS - HWTS No.2 Line 500kV E/SW

		Existing GIS - SYTS No.2 500kV Line No.1 Bus CB Line Side ROI
		Existing GIS - SYTS No.2 500kV Line No.1 Bus CB Bus Side ROI
		Existing GIS - HWTS No.2 500kV Line No.2 Bus CB Line Side ROI
		Existing GIS - HWTS No.2 500kV Line No.2 Bus CB Bus Side ROI
		Existing GIS - HWTS No.2 Line/ SYTS No.2 Line 500kV CB SYTS Line Side ROI
		Existing GIS - HWTS No.2 Line/ SYTS No.2 Line 500kV CB HWTS Line Side ROI
	Install	New SYTS No.2 500kV Line No.1 Bus CB
		New HWTS No.2 Line/ SYTS No.2 Line 500kV CB
		New HWTS No.2 500kV Line No.2 Bus CB
		New SYTS No.2 500kV Line No.1 Bus CB Line Side CT - Including 3 x off Single Phase Post Type 500kV CT
		New HWTS No.2 Line/ SYTS No.2 Line 500kV CB SYTS Line Side CT - Including 3 x off Single Phase Post Type 500kV CT
		New HWTS No.2 500kV Line No.2 Bus CB Line Side CT - Including 3 x off Single Phase Post Type 500kV CT
		New SYTS No.2 500kV Line No.1 Bus CB Line Side ROI - Including 2 x integrated earth switch
		New SYTS No.2 500kV Line No.1 Bus CB Bus Side ROI - Including 2 x integrated earth switch
		New HWTS No.2 500kV Line No.2 Bus CB Line Side ROI - Including 2 x integrated earth switch
		New HWTS No.2 500kV Line No.2 Bus CB Bus Side ROI - Including 2 x integrated earth switch

		<p>New HWTS No.2 Line/ SYTS No.2 Line 500kV CB SYTS Line Side ROI</p> <ul style="list-style-type: none"> - Including 1 x integrated earth switch
		<p>New HWTS No.2 Line/ SYTS No.2 Line 500kV CB HWTS Line Side ROI</p> <ul style="list-style-type: none"> - Including 1 x integrated earth switch
		- Install six (6) 500kV Surge Arresters
		- Install Nine (9) 500kV Post Insulators
		- Install three (3) CT Bay Marshalling Boxes
		- Install three (2) VT Bay Marshalling Boxes
		- Install three (3) Switchyard GPO and Lighting Marshalling Boxes
		- Install new three Interface Termination Cubicles Bay
Bay C	Remove	Existing GIS - KTS 500kV Line No.1 Bus CB
		Existing GIS - ROTS No.3 Line/ KTS Line 500kV CB
		Existing GIS - ROTS No.3 500kV Line No.2 Bus CB
		Existing GIS - KTS 500kV Line No.1 Bus CB Line Side CT
		Existing GIS - KTS 500kV Line No.1 Bus CB Bus Side CT
		Existing GIS - ROTS No.3 Line/ KTS Line 500kV CB KTS Line Side CT
		Existing GIS - ROTS No.3 Line/ KTS Line 500kV CB ROTS Line Side CT
		Existing GIS - ROTS No.3 500kV Line No.2 Bus CB Line Side CT
		Existing GIS - ROTS No.3 500kV Line No.2 Bus CB Bus Side CT

	Existing GIS - KTS 500kV Line No.1 Bus CB Line Side E/SW
	Existing GIS - KTS 500kV Line No.1 Bus CB Bus Side E/SW
	Existing GIS - KTS 500kV Line E/SW
	Existing GIS - ROTS No.3 500kV Line No.2 Bus CB Line Side E/SW
	Existing GIS - ROTS No.3 500kV Line No.2 Bus CB Bus Side E/SW
	Existing GIS - ROTS No.3 Line/ KTS Line 500kV CB KTS Line Side E/SW
	Existing GIS - ROTS No.3 Line/ KTS Line 500kV CB ROTS Line Side E/SW
	Existing GIS - ROTS No.3 Line 500kV E/SW
	Existing GIS - KTS 500kV Line No.1 Bus CB Line Side ROI
	Existing GIS - KTS 500kV Line No.1 Bus CB Bus Side ROI
	Existing GIS - ROTS No.3 500kV Line No.2 Bus CB Line Side ROI
	Existing GIS - ROTS No.3 500kV Line No.2 Bus CB Bus Side ROI
	Existing GIS - ROTS No.3 Line/ KTS Line 500kV CB KTS Line Side ROI
	Existing GIS - ROTS No.3 Line/ KTS Line 500kV CB ROTS Line Side ROI
Install	New KTS 500kV Line No.1 Bus CB
	New ROTS No.3 Line/ KTS Line 500kV CB
	New ROTS No.3 500kV Line No.2 Bus CB
	New KTS 500kV Line No.1 Bus CB Line Side CT - Including 3 x off Single Phase Post Type 500kV CT
	New ROTS No.3 Line/ KTS Line 500kV CB KTS Line Side CT

		- Including 3 x off Single Phase Post Type 500kV CT
		New ROTS No.3 500kV Line No.2 Bus CB Line Side CT - Including 3 x off Single Phase Post Type 500kV CT
		New KTS 500kV Line No.1 Bus CB Line Side ROI - Including 2 x integrated earth switch
		New KTS 500kV Line No.1 Bus CB Bus Side ROI - Including 2 x integrated earth switch
		New ROTS No.3 500kV Line No.2 Bus CB Line Side ROI - Including 2 x integrated earth switch
		New ROTS No.3 500kV Line No.2 Bus CB Bus Side ROI - Including 2 x integrated earth switch
		New ROTS No.3 Line/ KTS Line 500kV CB KTS Line Side ROI - Including 1 x integrated earth switch
		New ROTS No.3 Line/ KTS Line 500kV CB ROTS Line Side ROI - Including 1 x integrated earth switch
		- Install six (6) 500kV Surge Arresters
		- Install Nine (9) 500kV Post Insulators
		- Install three (3) CT Bay Marshalling Boxes
		- Install three (2) VT Bay Marshalling Boxes
		- Install three (3) Switchyard GPO and Lighting Marshalling Boxes
		- Install new three Interface Termination Cubicles Bay
Bay E	Remove	Existing GIS - Future F1 TRANS 500kV CB
		Existing GIS - Future F1 TRANS 500kV CB Bus Side CT

		Existing GIS - Future F1 TRANS 500kV CB TRANS Side CT
		Existing GIS - Future F1 TRANS 500kV CB Bus Side E/SW
		Existing GIS - Future F1 TRANS 500kV CB TRANS Side E/SW
		Existing GIS - Future F1 TRANS 500kV E/SW
		Existing GIS - Future F1 TRANS 500kV CB Bus Side ROI
		Existing GIS - Future F1 TRANS 500kV CB TRANS Side ROI
Bay F	Remove	Existing GIS - F2 TRANS No.1 Bus 500kV CB
		Existing GIS - F2 TRANS Non Auto 500kV CB
		Existing GIS - F2 TRANS No.2 Bus 500kV CB
		Existing GIS - F2 TRANS No.1 Bus 500kV CB Bus Side CT
		Existing GIS - F2 TRANS No.1 Bus 500kV CB TRANS Side CT
		Existing GIS - F2 TRANS Non Auto 500kV CB TRANS Side CT
		Existing GIS - F2 TRANS Non Auto 500kV CB Line Side CT
		Existing GIS - F2 TRANS No.2 Bus 500kV CB Line Side CT
		Existing GIS - F2 TRANS No.2 Bus 500kV CB Bus Side CT
		Existing GIS - F2 500/330kV TRANS 500kV VT "R" Phase
		Existing GIS - F2 500/330kV TRANS 500kV VT "W" Phase
		Existing GIS - F2 500/330kV TRANS 500kV VT "B" Phase
		Existing GIS - F2 TRANS No.1 Bus 500kV CB Bus Side E/SW
		Existing GIS - F2 TRANS No.1 Bus 500kV CB TRANS Side E/SW

	Existing GIS - F2 TRANS Non Auto 500kV CB TRANS Side E/SW
	Existing GIS - F2 TRANS Non Auto 500kV CB Line Side E/SW
	Existing GIS - F2 TRANS No.2 Bus 500kV CB Line Side E/SW
	Existing GIS - F2 TRANS No.2 Bus 500kV CB Bus Side E/SW
	Existing GIS - F2 TRANS 500kV E/SW
	Existing GIS - F2 TRANS No.1 Bus 500kV CB Bus Side ROI
	Existing GIS - F2 TRANS No.1 Bus 500kV CB TRANS Side ROI
	Existing GIS - F2 TRANS Non Auto 500kV CB Line Side E/SW
	Existing GIS - F2 TRANS Non Auto 500kV CB TRANS Side ROI
	Existing GIS - F2 TRANS Non Auto 500kV CB Line Side ROI
	Existing GIS - F2 TRANS No.2 Bus 500kV CB Line Side ROI
	Existing GIS - F2 TRANS No.2 Bus 500kV CB Bus Side ROI
	Existing GIS - No.1 500kV Bus E/SW
	Existing GIS - No.2 500kV Bus E/SW
Install (Part 1)	New F2 TRANS No.1 Bus 500kV CB
	New F2 TRANS No.2 Bus 500kV CB
	New F2 TRANS No.1 Bus 500kV CB TRANS Side CT - Including 3 x off Single Phase Post Type 500kV CT
	New F2 TRANS No.2 Bus 500kV CB Line Side CT - Including 3 x off Single Phase Post Type 500kV CT

		New F2 500/330kV TRANS 500kV VT "R" Phase
		New F2 500/330kV TRANS 500kV VT "W" Phase
		New F2 500/330kV TRANS 500kV VT "B" Phase
		New F2 TRANS No.1 Bus 500kV CB Bus Side ROI - Including 2 x integrated earth switch
		New F2 TRANS No.1 Bus 500kV CB Transformer Side ROI - Including 2 x integrated earth switch
		New F2 TRANS No.2 Bus 500kV CB Transformer Side ROI - Including 1 x integrated earth switch
		New F2 TRANS No.2 Bus 500kV CB Bus Side ROI - Including 2 x integrated earth switch
		- Install six (6) 500kV Surge Arresters
		- Install Nine (9) 500kV Post Insulators
		- Install three (3) CT Bay Marshalling Boxes
		- Install three (2) VT Bay Marshalling Boxes
		- Install three (3) Switchyard GPO and Lighting Marshalling Boxes
		- Install new three Interface Termination Cubicles Bay

APPENDIX B.2.

Scope to replace all poor condition 500kV Outdoor GIS assets with 500kV AIS

500kV Bay	Activity	Description (Secondary Equipment)
Bay A	Remove	SYTS 1 Digital Current Differential Relay
		SYTS 1 Digital Current Differential Relay
		SYTS 1 Backup Negative Sequence Overcurrent
		SYTS 1 Backup Remote Trip Interlock Relay
		SYTS 1 1B X CB Fail & Control (CBM)
		SYTS 1 CB Sensitive Current Check Relay (CBM)
		HWTS 1/ SYTS 1 X CB Fail & Control (CBM)
		HWTS 1/ SYTS 1 CB Sensitive Current Check (CBM)
		Bay A CBF Overcurrent Relay (CBM)
		HWTS 1 Digital Current Differential Relay
		HWTS 1 Digital Current Differential Relay
		HWTS 1 Over Voltage Relay
		HWTS 1 2B X CB Fail & Control (CBM)
		HWTS 1 CB Sensitive Current Check (CBM)
	Install	<ul style="list-style-type: none"> - Install new one-off SYTS No.1 Line No.1 Bus CB X & Y CB Management (CB Fail & Control) Scheme
		<ul style="list-style-type: none"> - Install new one-off SYTS No.1 500kV X Protection Scheme
		<ul style="list-style-type: none"> - Install new one-off SYTS No.1 500kV Y Protection Scheme
		<ul style="list-style-type: none"> - One-off SYTS No.1 500kV X Protection Scheme to remote end.
		<ul style="list-style-type: none"> - One-off SYTS No.1 500kV Y Protection Scheme to remote end.
		<ul style="list-style-type: none"> - Install new one-off SYTS NO.1/ HWTS No.1 Line CB X & Y CB Management (CB Fail & Control) Scheme

		<ul style="list-style-type: none"> - Install new one-off HWTS No.1 Line No.2 Bus CB X & Y CB Management (CB Fail & Control) Scheme
		<ul style="list-style-type: none"> - Install new one-off HWTS No.1 500kV X Protection Scheme
		<ul style="list-style-type: none"> - Install new one-off HWTS No.1 500kV Y Protection Scheme
		<ul style="list-style-type: none"> - Install new one-off HWTS No.1 500kV X Protection Scheme to remote end.
		<ul style="list-style-type: none"> - Install new one-off HWTS No.1 500kV Y Protection Scheme to remote end.
		<ul style="list-style-type: none"> - Install new three-off Interface Termination Cubicles Bay A
Bay B	Remove	SYTS 2 Digital Current Differential Relay
		SYTS 2 Digital Current Differential Relay
		SYTS 2 1B X CB Fail & Control (CBM)
		SYTS 2 1B CB Fail Relay (CBM)
		HWTS 2/SYTS 2 X CB Fail & Control (CBM)
		HWTS 2/SYTS 2 CB Fail Relay (CBM)
		HWTS 2 Digital Current Differential Relay
		HWTS 2 Digital Current Differential Relay
		HWTS 2 Over Voltage Relay
		HWTS 2 2B X CB Fail & Control (CBM)
	HWTS 2 2B CB Fail Relay (CBM)	
	Install	<ul style="list-style-type: none"> - Install new one-off SYTS No.2 Line No.1 Bus CB X & Y CB Management (CB Fail & Control) Scheme
		<ul style="list-style-type: none"> - Install new one-off SYTS No.2 500kV X Protection Scheme
		<ul style="list-style-type: none"> - Install new one-off SYTS No.2 500kV Y Protection Scheme
<ul style="list-style-type: none"> - One-off SYTS No.2 500kV X Protection Scheme to remote end. 		

		<ul style="list-style-type: none"> - One-off SYTS No.2 500kV Y Protection Scheme to remote end.
		<ul style="list-style-type: none"> - Install new one-off SYTS No.2/ HWTS No.2 Line CB X & Y CB Management (CB Fail & Control) Scheme
		<ul style="list-style-type: none"> - Install new one-off HWTS No.2 Line No.2 Bus CB X & Y CB Management (CB Fail & Control) Scheme
		<ul style="list-style-type: none"> - Install new one-off HWTS No.2 500kV X Protection Scheme
		<ul style="list-style-type: none"> - Install new one-off HWTS No.2 500kV Y Protection Scheme
		<ul style="list-style-type: none"> - Install new one-off HWTS No.2 500kV X Protection Scheme to remote end.
		<ul style="list-style-type: none"> - Install new one-off HWTS No.2 500kV Y Protection Scheme to remote end.
		<ul style="list-style-type: none"> - Install new three-off Interface Termination Cubicles Bay B
Bay C	Remove	KTS X Digital Current Differential Relay
		KTS Y Digital Current Diff/ Distance Relay
		KTS CB Fail Relay (CBM)
		ROTS 3/KTS CB Fail Relay (CBM)
		ROTS 3 X Digital Current Diff & Remote
		ROTS 3 Y Digital Current Differential Relay
		ROTS 3 Y Digital Current Diff Relay
		ROTS 3 Y Digital Current Differential Relay
		ROTS 3 Y Voltage Relay
		ROTS 3 Y Voltage Relay
		ROTS 3 Y Voltage Relay
		ROTS 3 Y Voltage Relay
		ROTS 3 Y Voltage Relay
		ROTS 3 CB Fail Relay (CBM)

	Install	<ul style="list-style-type: none"> - Install new one-off KTS Line No.1 Bus CB X & Y CB Management (CB Fail & Control) Scheme - Install new one-off KTS LINE 500kV X Protection Scheme - Install new one-off KTS LINE 500kV Y Protection Scheme - Install new one-off KTS LINE 500kV X Protection Scheme to remote end. - Install new one-off KTS LINE 500kV Y Protection Scheme to remote end. - Install new one-off KTS/ ROTS NO.3 Line CB X & Y CB Management (CB Fail & Control) Scheme - Install new one-off ROTS NO.3 Line No.2 Bus CB X & Y CB Management (CB Fail & Control) Scheme - Install new one-off ROTS NO.3 500kV X Protection Scheme - Install new one-off ROTS No.3 500kV Y Protection Scheme - Install new one-off ROTS NO.3 500kV X Protection Scheme to remote end. - Install new one-off ROTS No.3 500kV Y Protection Scheme to remote end. - Install new three-off Interface Termination Cubicles Bay C
Common Bays	Remove	<ul style="list-style-type: none"> #1 500 X Differential Relay #1 500 X Differential Relay #1 500 X Differential Relay #1 500 Y Differential Relay #1 500 Y Differential Relay #1 500 Y Differential Relay

		#2 500 X Differential Relay
		#2 500 X Differential Relay
		#2 500 X Differential Relay
		#2 500 Y Differential Relay
		#2 500 Y Differential Relay
		#2 500 Y Differential Relay
		500kV Sync and Bus POT Select
		500kV CB Sync Check
		500kV CB Control & Sync Check
		500kV Dummy CB POT Select
		SYTS 1 & 2 500kV Line POT Select
	Install (Part 1)	- Install new one off No.1 500kV Bus X High Impedance Bus Protection Scheme No. T24
		- Install new one off No.1 500kV Bus Y High Impedance Bus Protection Scheme No. T25
		- Install new one off No.2 500kV Bus X High Impedance Bus Protection Scheme No. T26
		- Install new one off No.2 500kV Bus Y High Impedance Bus Protection Scheme No. T27
		- Install new one off 500kV Bus Potential Selection Panel

APPENDIX B.3.

Scope to replace one diameter of 500kV GIS with AIS - 500kV AIS Bay

500kV Bay	Activity	Description (Primary Equipment)
Bay A	Install	New SYTS No.1 500kV Line No.1 Bus CB
		New HWTS No.1 Line/ SYTS No.1 Line 500kV CB
		New HWTS No.1 500kV Line No.2 Bus CB
		New SYTS No.1 500kV Line No.1 Bus CB Line Side CT Including 3 x off Single Phase Post Type 500kV CT
		New HWTS No.1 Line/ SYTS No.1 Line 500kV CB SYTS Line Side CT Including 3 x off Single Phase Post Type 500kV CT
		New HWTS No.1 500kV Line No.2 Bus CB Line Side CT Including 3 x off Single Phase Post Type 500kV CT
		New SYTS No.1 500kV Line No.1 Bus CB Line Side ROI Including 2 x integrated earth switch
		New SYTS No.1 500kV Line No.1 Bus CB Bus Side ROI Including 2 x integrated earth switch
		New HWTS No.1 500kV Line No.2 Bus CB Line Side Including 2 x integrated earth switch
		New HWTS No.1 500kV Line No.2 Bus CB Bus Side ROI Including 2 x integrated earth switch
		New HWTS No.1 Line/ SYTS No.1 Line 500kV CB SYTS Line Side ROI Including 1 x integrated earth switch
		New HWTS No.1 Line/ SYTS No.1 Line 500kV CB HWTS Line Side ROI Including 1 x integrated earth switch
		Install six (6) 500kV Surge Arresters

		Install Nine (9) 500kV Post Insulators
		Install three (3) CT Bay Marshalling Boxes
		Install three (2) VT Bay Marshalling Boxes
		Install three (3) Switchyard GPO and Lighting Marshalling Boxes
		Install one (1) No.1 500kV Bus X & Y High Impedance Bus Protection CT Summation Box
		Install one (1) No.2 500kV Bus X & Y High Impedance Bus Protection CT Summation Box
		Install new three Interface Termination Cubicles Bay

APPENDIX B.4.

Scope to replace one diameter of 500kV GIS with AIS - 500kV AIS Bay Extension

500kV Bay	Activity	Description (Secondary Equipment)
Bay A	Remove	SYTS 1 Digital Current Differential Relay
		SYTS 1 Digital Current Differential Relay
		SYTS 1 Backup Negative Sequence Overcurrent
		SYTS 1 Backup Remote Trip Interlock Relay
		SYTS 1 1B X CB Fail & Control (CBM)
		SYTS 1 CB Sensitive Current Check Relay (CBM)
		HWTS 1/ SYTS 1 X CB Fail & Control (CBM)
		HWTS 1/ SYTS 1 CB Sensitive Current Check (CBM)
		Bay A CBF Overcurrent Relay (CBM)
		HWTS 1 Digital Current Differential Relay
		HWTS 1 Digital Current Differential Relay
		HWTS 1 Over Voltage Relay
		HWTS 1 2B X CB Fail & Control (CBM)
		HWTS 1 CB Sensitive Current Check (CBM)
	Install	- Install new one-off SYTS No.1 Line No.1 Bus CB X & Y CB Management (CB Fail & Control) Scheme
		- Install new one-off SYTS No.1 500kV X Protection Scheme
		- Install new one-off SYTS No.1 500kV Y Protection Scheme
		- One-off SYTS No.1 500kV X Protection Scheme to remote end.

		- One-off SYTS No.1 500kV Y Protection Scheme to remote end.
		- Install new one-off SYTS NO.1/ HWTS No.1 Line CB X & Y CB Management (CB Fail & Control) Scheme
		- Install new one-off HWTS No.1 Line No.2 Bus CB X & Y CB Management (CB Fail & Control) Scheme
		- Install new one-off HWTS No.1 500kV X Protection Scheme
		- Install new one-off HWTS No.1 500kV Y Protection Scheme
		- Install new one-off HWTS No.1 500kV X Protection Scheme to remote end.
		- Install new one-off HWTS No.1 500kV Y Protection Scheme to remote end.
		- Install new three-off Interface Termination Cubicles Bay A