



31 January 2023

Attachment 8.8: Transmission Pricing Methodology

Ausgrid's 2024-29 Regulatory Proposal

Empowering communities for a resilient, affordable and net-zero future.



Contents

| | | |
|-----|--|----|
| 1. | Introduction..... | 3 |
| 1.1 | Revisions to the pricing methodology..... | 3 |
| 1.2 | Arrangements applicable to Ausgrid for the 2019-24 regulatory control period..... | 3 |
| 1.3 | Interpretation | 3 |
| 1.4 | Prescribed transmission services..... | 3 |
| 1.5 | Rule requirements | 4 |
| 2. | Transmission Pricing Methodology Guideline Requirements | 5 |
| 2.1 | Co-ordinating Network Service Provider | 5 |
| 2.2 | Summary of Proposal..... | 5 |
| 3. | Proposed Transmission Pricing Methodology..... | 7 |
| 3.1 | Calculation of the Aggregate Annual Revenue Requirement | 7 |
| 3.2 | Method of categorising exit, entry, shared and common service assets | 7 |
| 3.3 | Calculation of the Annual Service Revenue Requirement for each category of service..... | 8 |
| 3.4 | Allocation of the ASRR to specific assets and transmission network connection points | 9 |
| 3.5 | Provision for relaxation of TUOS locational side constraints | 12 |
| 3.6 | Transmission prices and charges..... | 12 |
| 3.7 | Contract demand charge..... | 12 |
| 3.8 | Setting of TUOS locational prices between annual price publications..... | 12 |
| 3.9 | System strength pass through charge..... | 13 |
| 4. | Billing Arrangements | 13 |
| 4.1 | Billing for prescribed transmission services | 13 |
| 4.2 | Payments between Transmission Network Service Providers..... | 13 |
| 5. | Prudential Requirements..... | 14 |
| 5.1 | Prudential Requirements for prescribed transmission services | 14 |
| 5.2 | Capital contribution or prepayment for a specific asset | 14 |
| 6. | Prudential discounts | 14 |
| 7. | Monitoring and compliance | 15 |
| 8. | Additional information requirements..... | 15 |
| | Appendix A: Details of cost allocation process..... | 16 |

1. Introduction

Ausgrid provides both transmission and distribution services through its network in Sydney, Newcastle, the Hunter Valley and Central Coast of NSW.

This document is Ausgrid's proposed transmission *pricing methodology* with respect to services provided through its transmission network, and is separate to the annual pricing proposal required to be submitted to the Australian Energy Regulator (AER) for distribution services under Chapter 6.18 of the National Electricity Rules (the Rules).

1.1 Revisions to the pricing methodology

This pricing methodology will apply from 1 July 2024 to 30 June 2029 and proposes amendments to the previous pricing methodology primarily to address the changes required by the introduction of *System Strength Charging* in accordance with the AEMC's Rule determination, Efficient Management of System Strength on the Power System Rule 2021, October 2021.

Transgrid is the *Co-ordinating Network Service Provider* for the NSW region, consequently Ausgrid's transmission *pricing methodology* must be consistent with Transgrid's methodology.

1.2 Arrangements applicable to Ausgrid for the 2019-24 regulatory control period

In the Framework and Approach paper, the AER has determined under clause 6.25(b) of the Rules that Ausgrid's *dual function assets* will remain subject to the Rules provisions on transmission pricing during the *regulatory control period*¹.

Clause 6.26 of the Rules establishes that the transmission pricing arrangements in Part J of Chapter 6A applies to Ausgrid's *dual function assets*. Clause 6A.24.2 requires Ausgrid to publish a *pricing methodology* for its *dual function assets*.

This *pricing methodology* directly reflects the *pricing principles for prescribed transmission services* set out in clause 6A.23 of the Rules. This standardised approach has been developed to conform with the steps and sequence set out in the Rules. Ausgrid has not proposed any alternative arrangements for its transmission *pricing methodology*.

1.3 Interpretation

All terms in this proposed transmission *pricing methodology* that are italicised have the meaning given to them in the AER's *transmission pricing methodology guidelines* or, where no definition is provided in that document, the Rules.

A reference to the Rules is taken to be a reference to the current version of the National Electricity Rules².

1.4 Prescribed transmission services

Ausgrid's proposed transmission *pricing methodology* relates to the provision of *prescribed transmission services*. These services are provided by *dual function assets*, which operate in parallel, and provide support to the higher voltage transmission network. The services provided by these assets include:

- Shared transmission services provided to customers directly connected to the transmission network and connected network service providers (*prescribed TUOS services*)

¹ AER, Framework and approach Ausgrid, Endeavour Energy and Essential Energy Regulatory control period commencing 1 July 2019, July 2017, p. 82.

² AEMC, National Electricity Rules, <http://www.aemc.gov.au/Electricity/National-Electricity-Rules/Current-Rules.html>

- Connection services provided to connect Ausgrid's distribution network to the transmission network (*prescribed exit services*)
- Grandfathered connection services provided to generators and customers directly connected to the transmission network that were in place or committed to be in place on 9 February 2006 (*prescribed entry services* and *prescribed exit services*)
- Services required under the Rules or in accordance with jurisdictional electricity legislation that are necessary to ensure the integrity of the transmission network, including through the maintenance of power system security and assisting in the planning of the power system (*prescribed common transmission services*).

In addition to the above services, at each *system strength connection point* on Ausgrid's transmission network, Ausgrid will recover from the relevant *Transmission Network User*, on a pass through basis, the *annual system strength charge* for the *system strength connection point* determined by Transgrid.

This proposed transmission *pricing methodology* does not relate to the provision of *negotiated transmission services* (deemed as *negotiated distribution services* under clause 6.24.2(c) of the Rules) provided by Ausgrid.

1.5 Rule requirements

This methodology has been prepared to meet the following requirements of the National Electricity Rules.

Clause 6A.24.1(b) of the Rules states that the *transmission pricing methodology* is a methodology, formula, process or approach that when applied by a TNSP:

- (1) allocates the aggregate annual revenue requirement (AARR) for *prescribed transmission services* to:
 - (i) the categories of *prescribed transmission services* for that provider; and
 - (ii) *transmission network connection points of Transmission Network Users*; and
- (2) determines the structure of the prices that a *Transmission Network Service Provider* may charge for each of the categories of *prescribed transmission services* for that provider.

The Rules also require that the *transmission pricing methodology* satisfy principles and guidelines established by the Rules. In particular, clause 6A.10.1(e) of the Rules requires that the proposed *transmission pricing methodology* must:

- (1) give effect to and be consistent with the *Pricing principles for prescribed transmission services* (that is to say, the principles set out in rule 6A.23); and
- (2) comply with the requirements of, and contain or be accompanied by such information as is required by, the *transmission pricing methodology guidelines* made for that purpose under rule 6A.25.

The AER issued *Pricing methodology guidelines* pursuant to clause 6A.25 of the Rules in 2022³.

³ AER, *pricing methodology guidelines – Electricity transmission network service providers*, 25 August 2022.

2. Transmission Pricing Methodology Guideline Requirements

2.1 Co-ordinating Network Service Provider

In accordance with clause 6A.29.1 of the Rules, Transgrid is the *Co-ordinating Network Service Provider* for NSW. For the purposes of transmission pricing there are a number of TNSPs in NSW⁴. These TNSPs are referred to in the rules as ‘appointing providers’. As an appointing provider, Ausgrid is required to annually provide Transgrid with a revised model of Ausgrid’s transmission network, with the approved AARR for its transmission system already allocated in accordance with this transmission pricing proposal. Ausgrid is also required to provide any other information reasonably required by Transgrid to ensure the proper calculation of prescribed transmission prices in New South Wales.

Note also that the following are calculated by the coordinating TNSP and *System Strength Service Provider* for NSW, Transgrid:

- The calculation of the *postage stamp rates* which form part of transmission prices, referred to in the AER Guidelines at 2.1(h)
- The *system strength charging* arrangements in accordance with the AER Guideline at 2.1(k)
- Prudent discounts referred to in the AER Guidelines at 2.1(o), which are also calculated as part of the *postage stamp* allocation.

2.2 Summary of Proposal

The AER’s *transmission pricing methodology guidelines* supplement and elaborate on the pricing principles contained in Chapter 6A of the Rules in so far as they specify or clarify:

- The information that is to accompany a proposed transmission *pricing methodology*,
- Permitted pricing structures for the recovery of the locational component of providing *prescribed TUOS services*
- Permitted postage stamp pricing structures for *prescribed common transmission services* and the recovery of the adjusted non-locational component of providing *prescribed TUOS services*
- The types of transmission system assets that are *directly attributable* to each category of *prescribed transmission services*
- Those parts of a proposed transmission *pricing methodology*, or the information accompanying it that will not be publicly disclosed without the consent of the TNSP.

As Ausgrid is an *appointing provider* of transmission services in NSW, Transgrid implements some aspects of the transmission pricing requirements. Ausgrid’s transmission *pricing methodology* (with relevant sections referenced) is limited to:

- Calculation of the Annual Aggregate Revenue Requirement for each year of the *regulatory control period* (section 3.1)
- Proposing a methodology to determine whether assets fall in to the categories of exit, entry, shared or common service (section 3.2 and Appendix A)
- Detailing the methodology for implementation of the priority ordering approach under clause 6A.23.2(d) of the Rules including three worked examples (Appendix A)

⁴ These are: Transgrid, Ausgrid, Evoenergy (formerly ActewAGL) and Directlink.

- Allocating the AARR to those asset classes of exit, entry, shared and common service, using an attributable cost share method, to determine an *Annual Service Revenue Requirement* (ASRR) for each category of service for each transmission network connection point. (section 3.3)
- Allocating the ASRR of each asset class to the specific assets within that asset class (section 3.4)
- Describing how asset costs which are associated with *prescribed entry services* and *prescribed exit services* at a *connection point*, which may be attributable to multiple *Transmission Network Users*, will be allocated (section 3.4.4)
- Recovering from the relevant *Transmission Network User*, on a pass through basis, the *annual system strength charge* for the *system strength connection point* determined by Transgrid
- Billing arrangements for a small number of direct connected transmission customers (section 4)
- Management of prudential requirements and prudent discounts for new or existing connections to the Ausgrid transmission network (sections 5 and 6)
- Detail of how Ausgrid intends to monitor and develop records of its compliance with its approved transmission *pricing methodology*, the *pricing principles for prescribed transmission services* (clause 6A.23) and part J of the Rules in general (section 7).

Elements of a *pricing methodology* that are required as part of the AER guidelines and National Electricity Rules that are carried out by Transgrid on behalf of Ausgrid are:

- Any adjustments required to be made to the locational component of the ASRR as required in the Rules⁵
- Any adjustments required to be made to the pre-adjusted non-locational component of the ASRR as required in the Rules⁶
- Allocation of the locational component of *prescribed TUOS services to transmission connection points*
- Establishing structure and price for common service, general, and locational charges at each of Ausgrid's *Transmission connection points*⁷
- The *system strength unit prices and the system strength charges* payable, if any, in relation to each of Ausgrid's *Transmission connection points*.

⁵ Rules, clause 6A.23.3(b).

⁶ Rules, clause 6A.23.3(e).

⁷ That is, Ausgrid *Transmission connection points* that supply Ausgrid's distribution network, not to be confused with Transgrid Network Boundary *Connection points* that supply Ausgrid's distribution network.

3. Proposed Transmission Pricing Methodology

3.1 Calculation of the Aggregate Annual Revenue Requirement

Ausgrid's network assets comprise distribution assets and dual function assets, which are subject to the pricing arrangements for transmission standard control services.

The portion of Ausgrid's annual revenue requirement relevant to *transmission standard control services* is established by the AER under clause 6.26(b)(1). To arrive at the AARR for *transmission standard control services* for the purposes of Part J of Chapter 6A, the *maximum allowed revenue* is adjusted in accordance with:

- (1) Rules clause 6.6 (relating to adjustments after the making of a building block determination)
- (2) Rules clause 6.13 (relating to revocation)
- (3) Subtracting the operating and maintenance costs expected to be incurred in the provision of *prescribed common transmission services* and *expected system strength service payments*, in accordance with clause 6A.22.1.

In relation to paragraph (3) above, as Transgrid is the *System Strength Service Provider* for NSW, Ausgrid will not incur any *system strength service payments*.

For the purposes of determining the AARR for transmission pricing, Ausgrid has complied with this requirement and has based the costs referred in (3) from budget projections of the following:

- Network switching and operations
- Administration and management of the business
- Network planning and development
- General overheads.

3.2 Method of categorising exit, entry, shared and common service assets

Ausgrid's AARR is for *prescribed transmission services* is recovered from transmission charges for the following categories of transmission service:

- *Prescribed exit services*, which include assets that are fully dedicated to serving a Transmission Customer or group of Transmission Customers at a single connection point and: (a) are deemed prescribed by virtue of the operation of clause 11.6.11 of the Rules; or (b) are provided to Network Service Providers at the boundary of the prescribed transmission network
- Prescribed transmission use of system (TUOS) services which include assets that are shared to a greater or lesser extent by all users across the transmission system and are not *prescribed common transmission services*, *prescribed entry services* or *prescribed exit services*
- *Prescribed common transmission services*, which are services that benefit all Transmission Customers and cannot be reasonably allocated on a locational basis. These services include system strength transmission services, which is the provision of facilities or services to meet the standard in clause S5.1.14 at system strength nodes.
- *Prescribed entry services* include assets that are fully dedicated to serving a Generator or group of Generators at a single *connection point*.

The first step in calculating *prescribed transmission service* prices is to classify each asset utilised in the provision of *prescribed transmission services* into one of the above categories of service. The delineation between the assets that provide *prescribed entry services*, *prescribed exit services*, *prescribed TUOS*

services and *prescribed common transmission services* is set out in clause 2.4 of the AER’s transmission pricing methodology guidelines.

The cost allocation process assigns the optimised replacement cost (ORC)⁸ of all prescribed assets to either *prescribed common transmission services* (assets that benefit all transmission customers) or individual network branches (transmission lines and transformers). Each branch is then defined as entry, exit or shared network. This process of cost allocation is explained in more detail in Appendix A.

3.3 Calculation of the Annual Service Revenue Requirement for each category of service

The second step in calculating *prescribed transmission service* prices is to calculate the *attributable cost share* for each category of service. Ausgrid has done this in accordance with clause 6A.22.3 of the Rules, as the ratio of:

- The costs of the transmission system assets *directly attributable* to the provision of that category of *prescribed transmission services* (as calculated in 3.2 above); to
- The total costs of all the TNSP’s transmission system assets *directly attributable* to the provision of *prescribed transmission services* (also calculated in 3.2 above).

For example, if the ORCs of prescribed services assets have been allocated to the applicable categories of *prescribed transmission services* as shown in Table 1 then the attributable costs shares are calculated as:

$$\begin{aligned} \text{Attributable Cost Share}_{\text{EXIT}} &= \text{ORC}_{\text{EXIT}} / \text{ORC}_{\text{TOTAL}} \\ &= \$6,972,222 / \$43,050,000 \\ &= 0.162 \end{aligned}$$

The attributable cost shares of the other categories are calculated in the same manner as shown in Table 2.

Table 1. Costs allocated to categories of prescribed transmission services

| Category | ORC |
|----------------|-------------------|
| Exit service | 6,972,222 |
| Entry service | 1,761,111 |
| TUOS service | 33,566,667 |
| Common Service | 750,000 |
| Total | 43,050,000 |

Table 2. Attributable Cost Shares

| Category | ORC | Attributable Cost Share |
|----------------|-------------------|-------------------------|
| Exit service | 6,972,222 | 0.162 |
| Entry service | 1,761,111 | 0.041 |
| TUOS service | 33,566,667 | 0.780 |
| Common Service | 750,000 | 0.017 |
| Total | 43,050,000 | 1.000 |

The third step in calculating *prescribed transmission service* prices is to allocate the AARR to each category of *prescribed transmission service* in accordance with the attributable cost share for each such category of services. This allocation results in the annual service revenue requirement (ASRR) for that category of services.

⁸ Consistent with clause 6A.22.3 (b) of the Rules.

Assuming an AARR of \$2,504,434 and applying the attributable cost shares determined above the ASRR for each category of prescribed services is calculated as:

$$\begin{aligned} \text{ASRR}_{\text{EXIT}} &= \text{AARR} \times \text{Attributable Cost Share}_{\text{EXIT}} \\ &= \$2,504,434 \times 0.162 \\ &= \$405,609 \end{aligned}$$

The ASRRs of the other categories of service are calculated in the same manner, as shown in Table 3.

Table 3. Annual Service Revenue Requirements

| Category | Attributable Cost Share | Annual Service revenue Requirement (ASRR) |
|----------------|-------------------------|---|
| Exit Service | 0.162 | 405,609 |
| Entry Service | 0.041 | 102,453 |
| TUOS Service | 0.780 | 1,952,741 |
| Common Service | 0.017 | 43,631 |
| Total | 1.000 | 2,504,434 |

3.4 Allocation of the ASRR to specific assets and transmission network connection points

The fourth step in calculating *prescribed transmission service* prices is to allocate the ASRR for *prescribed entry services, prescribed exit services and prescribed TUOS services* to each transmission network connection point in accordance with the principles of clause 6A.23.3 of the Rules.

Prescribed entry services

The whole of the ASRR for *prescribed entry services* is allocated to *transmission network connection points* in accordance with the attributable *connection point* cost share for *prescribed entry services* that are provided by the TNSP at that *connection point*.

The attributable *connection point* cost share for *prescribed entry services* is the ratio of the costs of the transmission system assets *directly attributable* to the provision of *prescribed entry services* at that *transmission network connection point* to the total costs of all the TNSP's transmission system assets *directly attributable* to the provision of *prescribed entry services*.

For example, consider two generators, Gen A1 and Gen A2 that receive *prescribed entry services* and the cost allocation methodology has allocated the ORCs of assets *directly attributable* to entry services to them as shown in Table 4:

$$\begin{aligned} \text{Attributable Connection point Cost Share}_{\text{GEN A1}} &= \text{ORC}_{\text{GEN A1}} / \text{ORC}_{\text{ENTRY}} \\ &= \$1,033,333 / \$1,761,111 \\ &= 0.587 \end{aligned}$$

The attributable *connection point* cost shares of the other generator is calculated in the same manner as shown in Table 5.

Table 4. Prescribed entry services ORCs

| Entry | ORC |
|---|------------------|
| Gen A1 | 1,033,333 |
| Gen A2 | 727,778 |
| Total ORC of prescribed entry assets | 1,761,111 |

Table 5. Attributable connection point cost shares

| Entry | ORC | Attributable connection point cost share |
|--------------|------------------|--|
| Gen A1 | 1,033,333 | 0.587 |
| Gen A2 | 727,778 | 0.413 |
| Total | 1,761,111 | 1.000 |

The ASRR allocated to the Gen AI *transmission network connection point* is calculated as follows:

$$\begin{aligned}
 \text{ASRR}_{\text{GEN AI}} &= \text{ASRR}_{\text{ENTRY}} \times \text{Attributable connection point cost share}_{\text{GEN AI}} \\
 &= \$102,453 \times 0.587 \\
 &= 60,114
 \end{aligned}$$

The ASRR of the other generator *connection points* is calculated in the same manner.

Table 6. Connection point ASRRs (Entry)

| Entry | ORC | Attributable connection point cost share | Connection point ASRR |
|--------------|------------------|--|-----------------------|
| Gen A1 | 1,033,333 | 0.587 | 60,114 |
| Gen A2 | 727,778 | 04.413 | 42,338 |
| Total | 1,761,111 | 1.000 | 102,453 |

The ASRR related to the entry assets for each generator is recovered via a daily fixed charge. For example, GEN AI will be charged a daily rate of:

$$\begin{aligned}
 \text{GEN AI Fixed Charge} &= \$60,144/365 \text{ days}^9 \\
 &= \$226.961 \text{ day for the relevant financial year}
 \end{aligned}$$

No other charges will be applied to generators, as the transmission network is built for load, rather than generation. Common services and TUOS services are therefore only allocated to loads.

Prescribed exit services

The whole of the ASRR for *prescribed exit services* is allocated to transmission *network connection points* in accordance with the attributable *connection point cost share* for *prescribed exit services* that are provided by the TNSP at that *connection point*.

The attributable *connection point cost share* for *prescribed exit services* is the ratio of the costs of the transmission system assets *directly attributable* to the provision of *prescribed exit services* at that *transmission network connection point* to the total costs of all the transmission system assets *directly attributable* to the provision of *prescribed exit services*.

The ASRRs of the prescribed exit connection points are calculated in the same manner as for the entry *connection points*.

Table 7. Connection point ASRRs (Exit)

| Exit | ORC | Attributable connection point cost share | Connection point ASRR |
|---------|-----------|--|-----------------------|
| Load A1 | 2,083,333 | 0.299 | 121,198 |
| Load A2 | 1,405,556 | 0.202 | 81,768 |
| Load B1 | 2,633,333 | 0.378 | 153,194 |
| Load C1 | 850,000 | 0.122 | 49,449 |

⁹ 366 days is used for this calculation if a leap year.

| Exit | ORC | Attributable connection point cost share | Connection point ASRR |
|--------------|------------------|--|-----------------------|
| Total | 6,972,222 | 1.000 | 405,609 |

The ASRR related to the exit assets for each load is recovered via a daily fixed charge. For example, Load AI will be charged a daily rate of:

$$\begin{aligned} \text{Load AI Fixed Charge} &= \$121,198/365 \text{ days} \\ &= \$332.05 \text{ per day for the relevant financial year.} \end{aligned}$$

Locational charges, TUOS general charges and common service charges will also apply to Load AI, and are calculated by Transgrid as the Co-ordinating TNSP appointed by Ausgrid.

Prescribed transmission Use of System (TUOS) services

The prescribed TUOS (shared network) services ASRR is recovered from:

- *Prescribed TUOS services* (locational component)
- *Prescribed TUOS services* (the adjusted non-locational component)

Clause 6A.23.3(b) of the Rules requires that the pre-adjusted locational component is to be adjusted by:

subtracting any amount estimated as proceeds from *auctions* or any portion of *settlements residue* allocated to the *directional interconnector* which is not the subject of a *SRD agreement* estimated to be receivable by the *Transmission Network Service Provider* from the *connection points* for each relevant *directional interconnector* as referred to in clause 3.18.4, with that amount including an adjustment calculated in accordance with paragraph (f); and

In NSW, compliance with this clause is carried out by Transgrid as the co-ordinating TNSP, as Ausgrid is not a direct recipient of settlements auction amounts¹⁰. Transgrid makes relevant adjustments to account for settlements auction amounts in its *pricing methodology*, consistent with clause 6A.23.3(b)(1). Please refer to Transgrid's transmission *pricing methodology* with respect to compliance with this clause.

Allocation of the locational component of *prescribed TUOS services* is carried out by Transgrid using the methodology approved by the AER, which assigns a proportion of shared network costs to individual customer *connection points*. Details of this calculation can be found in Transgrid's *transmission pricing proposal*.

This allocation of the *locational component of prescribed TUOS services* by Transgrid requires data for Ausgrid's transmission network, its costs and utilisation.

The remainder of the ASRR (the pre-adjusted non-locational component) is to be adjusted:

- Where the proceeds of settlements auctions exceed the locational ASRR attributed to an interconnector, the residual (if any) is subtracted as required by clause 6A.23.3(e) of the Rules
- By subtracting or adding any remaining settlements residue (after adjustment of the locational allocation for residues attributable to interconnectors). This is primarily the portion of settlements residues due to intra-regional loss factors expected to be distributed or recovered, in accordance with clause 3.6.5(a) of the Rules
- For any revenue over or under-recovery amount from previous years (clause 6A.23.3(e)(5))
- For any amount arising as a result of the application of the side constraint on TUOS charge changes (clause 6A.23.4(b)(3))

¹⁰ Settlements residues arise from two mechanisms:

- Inter-regional amounts accumulate between regional reference nodes as a result of price differences due to losses and network constraints. The rights to these inter-regional price differences are auctioned to participants in settlements reserve auctions, conducted quarterly
- Intra-regional amounts primarily arise because of differences between the marginal loss factors used for settlements and the physical losses taking place on the network.

- For any amount arising as a result of the application of prudent discounts in accordance with clause 6A.26.1(d)-(g) of the Rules.

These adjustments are carried out by Transgrid as the Co-ordinating TNSP in NSW. Ausgrid provides advice to Transgrid of any expected under-recovery or over-recovery amount from previous years to be used by Transgrid in setting prices each year.

Costs that could be allocated to more than one category of service

Ausgrid allocates substation costs that are *directly attributable* to entry, exit, common and TUOS services and then allocates the residual costs, known as substation local costs, to entry, exit and TUOS services on the basis of the number of pricing branches (transmission lines and transformers) connected to that substation.

Clause 6A.23.2(d) of the Rules has a priority ordering concept for the allocation of those costs which could be attributable to more than one category of *prescribed transmission services*.

The substation local costs are allocated to the various prescribed services in accordance with the provisions of clause 6A.23.2(d) of the Rules having regard to the stand alone costs associated with the provision of *prescribed TUOS services* and *prescribed common transmission services* with the remainder being allocated to *prescribed entry services* and *prescribed exit services*.

Details on Ausgrid's application of priority ordering can be found in Appendix A.

3.5 Provision for relaxation of TUOS locational side constraints

The implementation of clause 6A.23.4(b)(2) of the Rules allows for the relaxation of the 2% side constraint for material changes in *connection point* load or renegotiation of connection agreements, subject to AER approval.

In the event that a Transmission Customer requests a material increase in demand at an existing *connection point*, Ausgrid, together with Transgrid, as the Co-ordinating TNSP in NSW will seek approval from the AER to set the prescribed TUOS - locational price as intended by clause 6A.23.4(b)(2) of the Rules.

3.6 Transmission prices and charges

Calculation of prices for all *prescribed transmission services* in NSW is carried out by Transgrid as the Co-ordinating TNSP in NSW. Please refer to Transgrid's *pricing methodology* for the calculation of prices for Ausgrid's transmission network. Transgrid receives Ausgrid's transmission models with all assets allocated to the relevant asset classes and a portion of the AARR allocated to give the ASRR for each class. Assets within each asset class have already been allocated a portion of the ASRR for that class in accordance with this *pricing methodology*.

3.7 Contract demand charge

To the extent that it is permitted by Transgrid *pricing methodology*, Ausgrid is able to propose locations on its transmission network where an excess demand charge is to apply. Ausgrid nominates to Transgrid the particular location of one of Ausgrid's transmission connections points (whether that is a *connection point* direct to Transgrid or one that connects Ausgrid's distribution network to its transmission network) where excess demand charging is to apply. Ausgrid also proposes an agreed maximum demand for this *connection point*. If Ausgrid's maximum demand exceeds the contract agreed maximum demand level at any time during the financial year then an Excess Demand Charge applies.

Transgrid determines the rates for the Contract Demand Charge as the co-ordinating TNSP in NSW. Details on the contract maximum demand charge can be found in Transgrid's transmission *pricing methodology*.

3.8 Setting of TUOS locational prices between annual price publications

In the event that Ausgrid requires a TUOS locational price at a new *connection point* or at a connection where the load has changed significantly after prescribed TUOS service locational prices have been determined and published, an interim price, not subject to the side constraints of clause 6A.23.4 (f) of the Rules, will be determined by Transgrid as the co-ordinating TNSP in NSW. This will be calculated using the

prevailing pricing models with demands estimated in a manner consistent with clause 2.2(f) of the *transmission pricing methodology guidelines*.

A price subject to the side constraints of clause 6A.23.4 (f) of the Rules will be determined and published at the next annual price determination.

3.9 System strength pass through charge

In accordance with clause 6A.23.6(b) of the Rules, at each *system strength connection point* on Ausgrid's network, Ausgrid will recover from the relevant *Transmission Network User*, on a pass through basis, the *annual system strength charge* for the *system strength connection point* determined by Transgrid, being the *System Strength Service Provider* for NSW.

Clause 6A.23.6(c) of the Rules requires the amount, structure and timing of the amount billed will replicate, as far as is reasonably practical, the amount, structure and timing of the corresponding system strength charge billed to Ausgrid. To comply with this requirement, Ausgrid will replicate as far as reasonably practical, the amount, structure and timing of the annual system strength charge, in accordance with the charging information provided and billed by Transgrid.

4. Billing Arrangements

4.1 Billing for prescribed transmission services

Consistent with the clause 6A.27.1 of the Rules, Ausgrid will calculate the transmission service charges and *system strength charges* payable by *Transmission Network Users* connected to the Ausgrid transmission network, in accordance with the transmission service prices published under clause 6A.24.2 as calculated by Transgrid. The prices calculated by Transgrid that are relevant to the Ausgrid transmission network are published on the Transgrid website.

Where charges are determined for *prescribed transmission services* from metering data, these charges will be based on kW or kWh obtained from the metering data managed by AEMO.

Ausgrid will issue bills to *Transmission Network Users* for *prescribed transmission services* which satisfy or exceed the minimum information requirements specified in clause 6A.27.2 of the Rules on a monthly basis or as agreed between the parties.

Consistent with clause 6A.27.3 of the Rules, a *Transmission Network User* must pay charges for *prescribed transmission services* properly charged to it and billed in accordance with the *transmission pricing methodology* of the relevant *Transmission Network Service Provider* by the date specified on the bill. For the avoidance of doubt, Ausgrid's transmission connected customer's bills are sent to their retailer, rather than to the customer directly.

4.2 Payments between Transmission Network Service Providers

Consistent with clause 6A.27.4 of the Rules, Transgrid is the *Co-ordinating Network Service Provider* in NSW under 6A.29.1 of the Rules and will pay to each other relevant *Transmission Network Service Provider* the revenue which is estimated to be collected during the following year by the first provider as charges for *prescribed transmission services* for the use of transmission systems owned by those other *Transmission Network Service Providers*.

Such payments will be determined by Transgrid as the *Co-ordinating Network Service Provider* for the region.

Financial transfers payable under clause 6A.27.4 of the Rules will be paid in equal monthly instalments or as documented in revenue collection agreements negotiated between the parties.

5. Prudential Requirements

5.1 Prudential Requirements for prescribed transmission services

Consistent with clause 6A.28.1 of the Rules, Ausgrid may require a *Transmission Network User* to establish prudential requirements for either or both connection services and transmission use of system services. These prudential requirements may take the form of, but need not be limited to, capital contributions, pre-payments or financial guarantees.

The requirements for such prudential requirements will be negotiated between the parties and specified in the applicable connection agreement.

5.2 Capital contribution or prepayment for a specific asset

Consistent with clause 6A.28.2 of the Rules, where Ausgrid is required to construct or acquire specific assets to provide *prescribed connection services*¹¹ or *prescribed TUOS services* to a *Transmission Network User*, Ausgrid may require that user to make a capital contribution or prepayment for all or part of the cost of the new assets installed.

In the unlikely event that a capital contribution is required, any contribution made will be taken into account in the determination of *prescribed transmission service* prices applicable to that user by way of a proportionate reduction in the ORC of the asset(s) used for the allocation of prescribed charges or as negotiated between the parties.

In the event that a prepayment is required any prepayment made will be taken into account in the determination of *prescribed transmission service* prices applicable to that user in a manner to be negotiated between the parties.

The treatment of such capital contribution or prepayments for the purposes of a revenue determination will in all cases be in accordance with the relevant provisions of the Rules.

Ausgrid may require a bank guarantee from a transmission customer, to cover the financial year of a transmission investment made by Ausgrid for the customer. Bank guarantees will only be relevant in cases where such investments relate to the construction of prescribed transmission assets. Such guarantees will be made in agreement with the customer and hold funds as security for Ausgrid in the event that the customer does not provide a satisfactory income stream through payment for TUOS charges over an agreed period of time.

6. Prudential discounts

Ausgrid is required to provide information to Transgrid in relation to prudent discounts relating to Ausgrid's transmission customers. Transgrid adjusts, in accordance with rule 6A.26.1(d)-(g), the non-locational component of the ASRR for *prescribed TUOS services* for the amount of any anticipated under-recovery arising from prudent discounts applied. Transgrid's transmission *pricing methodology* sets out the calculation of the adjustments and then application of those adjustments under 6A.26.1(d)-(g), as Transgrid is the Co-ordinating TNSP for NSW. The calculation of the discount amount is carried out as the difference between the revenue earned with the discounted prices compared to the revenues earned if the maximum allowed prices had been applied, consistent with the Rules. This amount is provided by Ausgrid to Transgrid as part of the annual pricing process. Ausgrid has a prudent discount arrangement with one transmission customer, details of which are attached as a separate confidential document as part of this *pricing methodology*.

¹¹ The scope for prescribed connection services is limited to certain connections subject to transitional arrangements under Rule 11.6.11, generally connections to the transmission system between network service providers. Other connections are classified as negotiated transmission services.

7. Monitoring and compliance

As a regulated business Ausgrid is required to maintain compliance monitoring and reporting systems to ensure compliance with its NSW DNSP License, applicable AER Determinations and other obligations under the National Electricity Rules together with other legislative obligations.

In order to monitor and maintain records of its compliance with its approved transmission *pricing methodology*, the *pricing principles for prescribed transmission services*, and part J of the Rules Ausgrid proposes to:

- Maintain the specific obligations arising from part J of the Rules (*Prescribed transmission services - Regulation of Pricing*) in Ausgrid's compliance management system
- Maintain electronic records of the annual calculation of prescribed transmission prices and supporting information
- Periodically subject its transmission pricing models and processes to functional audit by suitably qualified persons.

8. Additional information requirements

Ausgrid does not consider transitional arrangements necessary as a result of the implementation of this proposed transmission *pricing methodology*. Ausgrid does not have any relevant derogations in accordance with chapter 9 of the Rules, nor are there any applicable transitional arrangements arising from chapter 11 of the Rules relevant to this proposed transmission *pricing methodology*.

Appendix A: Details of cost allocation process

A detailed cost allocation process is used to assign the optimised replacement cost (ORC) of all prescribed service assets to either common service (assets that benefit all transmission customers), network branches (transmission lines or transformers) and prescribed entry or *prescribed exit services* in a manner consistent with Section 2.4 of the *transmission pricing methodology guidelines*.

The cost allocation process is summarised as follows:

Step 1: Initial Asset Cost Allocation

Assets and their ORCs are assigned to one of the following primary asset categories:

- Transmission lines
- Transformers
- Circuit breakers
- Common service assets (communications, reactive support, office buildings etc.)
- Substation local assets (ancillary equipment, civil work, and establishment).

The following plant items are not separately identified in ORC values and are incorporated into the ORC of the associated primary items above:

- Bus work;
- Secondary systems including protection and instrument transformers.

Step 2: Allocation to Classes of Service

Assets are allocated to the classes of prescribed service in accordance with the provisions of Section 2.4 of the *transmission pricing methodology guidelines*. In the case of circuit breakers, each circuit breaker has its replacement cost divided evenly between the branches to which it is *directly attributable*. Any circuit breaker that is not *directly attributable* to any branch together with substation local costs identified in step 1 become subject to the priority ordering process.

In the case of a connection asset attributable to multiple network users, such as a transformer, serving multiple transmission customers at a *connection point* (which may provide *prescribed entry services* and/or *prescribed exit services*) the cost of the shared connection asset will be allocated between the network users in accordance with a demand related allocation or as negotiated between the connected parties.

Step 3: Priority Ordering

In the case of those costs which would be attributable to more than one category of *prescribed transmission services*, specifically the substation local assets identified in step 1 and those circuit breakers identified as substation local costs in step 2, costs will be allocated in accordance with the provisions of clause 6A.23.2(d) of the Rules having regard to the stand alone costs associated with the provision of *prescribed TUOS services* and *prescribed common transmission services* with the remainder being allocated to *prescribed entry services* and *prescribed exit services*. The implementation of the priority ordering process is detailed below.

Priority Ordering Methodology

Rules Requirement

Clause 6A.23.2(d) of the Rules requires that:

Where, as a result of the application of the attributable cost share, a portion of the AARR would be attributable to more than one category of *prescribed transmission services*, that attributable cost share is to

16 | Attachment 8.8: Ausgrid Transmission Pricing Methodology

be adjusted and applied such that any costs of a transmission system asset that would otherwise be attributed to the provision of more than one category of prescribed transmission services, is allocated as follows:

1. to the provision of *prescribed TUOS services*, but only to the extent of the stand-alone amount for that category of *prescribed transmission services*;
2. if any portion of the costs of a transmission system asset is not allocated to *prescribed TUOS services*, under subparagraph (1), that portion is to be allocated to *prescribed common transmission services*, but only to the extent of the stand-alone amount for that category of *prescribed transmission services*;
3. if any portion of the costs of a transmission system asset is not attributed to *prescribed transmission services* under subparagraphs (1) and (2), that portion is to be attributed to *prescribed entry services* and *prescribed exit services*.

Stand-alone amount is defined as:

For a category of *prescribed transmission services*, the costs of a transmission system asset that would have been incurred had that transmission system asset been developed, exclusively to provide that category of *prescribed transmission services*.

AEMC Rule determination

In its rule determination the AEMC provided the following guidance on the application of the priority ordering approach for the allocation of costs which can be attributed to more than one type of service¹²:

“The Commission has maintained a priority ordering approach for the allocation of expenses or costs which can be attributed to more than one type of service. The cascading principle adopted by the Commission is based on the premise that users are seen to be the 'cause' of transmission investment. Therefore, costs should be first allocated to prescribed transmission use of system services on a stand-alone basis and then to *prescribed common transmission services*. Where a service/cost cannot justifiably be attributed to TUOS or common services it should be allocated to entry and exit services.”

In developing this methodology, Ausgrid has had regard for the following example in the rule determination¹³:

Consider a substation costing \$30 million that was developed:

- Partly in order to provide *Prescribed TUOS services*
- Partly in order to provide *Prescribed common transmission services*
- Partly in order to provide *prescribed exit services*.

Then assume that had the substation been developed solely to provide *prescribed TUOS services*, it could have been much smaller and would have cost only \$10 million. Had the substation been developed solely in order to provide *prescribed common transmission services*, it would have cost \$5 million. Finally, had the substation been developed solely in order to provide *prescribed exit services*, it would have cost \$20 million.

The application of the principle would then lead to the \$30 million cost of the substation being attributed to *prescribed transmission service* categories as follows:

- \$10 million to the *prescribed TUOS services* ASRR
- \$5 million to the *prescribed common services* ASRR
- The remaining \$15 million to the prescribed exit service ASRR.

Objective and General Approach

The proposed allocation methodology relies on the assumption that substation infrastructure and establishment costs are proportionate to the number of high voltage circuit breakers in the substation.

¹² Rule Determination for National Electricity Amendment (Pricing of *Prescribed transmission services*) Rule 2006, p5.

¹³ Ibid p. 37.

Based on this assumption, the appropriate allocator for substation infrastructure and establishment costs for a stand-alone arrangement is the ratio of the number of high voltage circuit breakers in the stand-alone arrangement to the number of high voltage circuit breakers in the whole substation.

Step 1: Branch Identification

Identify the branches, being the lines, transformers, major reactive devices and exits/entries in the substation which provide prescribed TUOS, *prescribed common transmission services* and exit or entry services, in the substation.

Step 2: Allocation of Circuit Breakers to Branches

For each high voltage circuit breaker in the substation identify the branches directly connected to it. Any circuit breaker that does not directly connect to a branch is excluded from allocation and all costs associated with it are added to the substation infrastructure and establishment cost.

Count the total number of circuit breakers directly connected to branches.

As a general rule, Distribution Network Service Providers (DNSPs) are classified as a prescribed exit service while Generators are classified as a prescribed entry service. Negotiated services are not part of the regulated asset base and fall outside the priority ordering process detailed in clause 6A.23.2 (d) of the Rules.

Step 3.1: Stand-alone arrangements for Prescribed TUOS

With reference to the number of lines providing *prescribed TUOS services* determine the number of circuit breakers required to provide TUOS services of an equivalent standard on a stand-alone basis. The stand-alone configuration is the simplest substation configuration (in the absence of development) had it been developed to provide a prescribed TUOS service. This may be done by way of a look up of typical stand-alone configurations.

Step 3.2: Stand-alone arrangements for Prescribed common transmission services

With reference to the number of lines providing *prescribed TUOS services* and the devices providing prescribed common service determine the number of circuit breakers required to provide *prescribed common transmission services* of an equivalent standard on a stand-alone basis. The stand-alone configuration is the simplest substation configuration (in the absence of development) had it been developed to provide a prescribed common service. This may be done by way of a look up of typical stand-alone configurations.

Step 4: Allocation of substation infrastructure and establishment costs

Step 4.1: Allocation of Prescribed TUOS

Allocate a portion of substation infrastructure and establishment costs to prescribed TUOS according to the ratio of the high voltage circuit breakers identified in step 3.1 to the total number of high voltage circuit breakers connected to branches in the substation identified in step 2.

Step 4.2 Calculate the Unallocated Substation Infrastructure Costs after TUOS Allocation

Calculate the Unallocated substation infrastructure cost by subtracting the amount calculated in step 4.1 from the total substation infrastructure amount.

Step 4.3 Allocation of Prescribed Common Service

Allocate a portion of the substation infrastructure and establishment costs to prescribed common service based on to the ratio of the high voltage circuit breakers providing *prescribed common transmission services* identified in step 3.2 to the total number of high voltage circuit breakers connected to branches in the substation. If the common service portion of substation infrastructure is greater than the Unallocated costs, then the Unallocated portion only is attributed to prescribed common service. In this instance, nothing will be attributed to *prescribed entry services* and *prescribed exit services*.

Step 4.4 Calculate the Unallocated Substation Infrastructure Costs after Common Service Allocation

Calculate the Unallocated substation infrastructure cost by subtracting the amount calculated in step 4.3 from the amount calculated in step 4.2.

Step 4.5 Allocation of Prescribed Entry and Exit Service

Allocate the remaining substation infrastructure and establishment costs (calculated in step 4.4) to each branch providing prescribed exit or entry services based on the ratio of the high voltage circuit breakers providing the entry or exit service to the branch to the total number of high voltage circuit breakers providing entry or exit services or in accordance with the TNSP's cost allocation methodology as appropriate.

Step 4.6 Allocation of Assets that provide both Entry and Exit Services

Clause 2.1(d)(3) of the AER guidelines states that a TNSP must provide:

Details of how the AARR will be allocated to derive the ASRR for each category of *prescribed transmission service*, including:

- (3) how asset costs which may be attributable to both *prescribed entry services* and *prescribed exit services* will be allocated.

Ausgrid proposes that where assets can be defined as both entry and exit services, that the allocation of the remainder of costs (after completing allocation to TUOS and common service) to be allocated on a simple proportion of circuit breakers that immediately connect those customers, for each service against the total number of circuit breakers of entry and exit services combined.

Consider Worked Example 1. Suppose that next to the negotiated service, a generator is connected to the busbar via a single circuit breaker and next to that yet another DNSP exit load connected via a single circuit breaker. In that case, there are now two circuit breakers for DNSP exit loads, and one circuit breaker for generator entry service. In that case, two thirds of the remaining \$1.5 million entry/exit service cost will be charged to the exit service and one third to the entry service.

This cost allocation will apply unless negotiated service arrangements apply between the parties, in which case the cost allocation in these particular circumstances will be negotiated between the parties.

Step 4.7 Allocation of Exit Assets a Connection point with Multiple Transmission Customers

Clause 2.1(e)(1)C of the guidelines states that a TNSP must provide:

Details of how the ASRR for each category of *prescribed transmission service* will be allocated to each *transmission connection point*, including:

- (1) how the attributable *connection point* cost share for both *prescribed entry services* and *prescribed exit services* will be calculated in accordance with clause 6A.22.4 of the National Electricity Rules, including:
 - c) how asset costs allocated to *prescribed entry services* and *prescribed exit services* at a *connection point*, which may be attributable to multiple *Transmission Network Users*, will be allocated.

Where exit or entry assets are shared between several customers, whether load and/or generation, that the allocation of the remainder of costs (after completing allocation to TUOS and common service) to be allocated on a simple proportion of the circuit breakers that immediately connect that customer to the exit/entry point against the total number of the same circuit breakers. This is the same method as that outlined above at step 4.6.

Notes

- Costs are only allocated in step 4 until fully allocated.
- Consistent with clause 6A.23.2(d)(3) of the Rules it is possible that no costs will be attributed to entry and exit services.
- New and existing negotiated service assets are excluded from the analysis as any incremental establishment costs associated with them are taken to be included in the negotiated services charges on a causation basis.
- The assessment of standalone arrangements only needs to be conducted once per substation except where changes to the configuration of the substation occur.

Definition - Branches

As illustrated by Figure 1 below a “Branch” is a collection of assets (e.g. lines, circuit breakers, capacitors, buses and transformers) that provide a transmission service.

Figure 1. Branch diagram

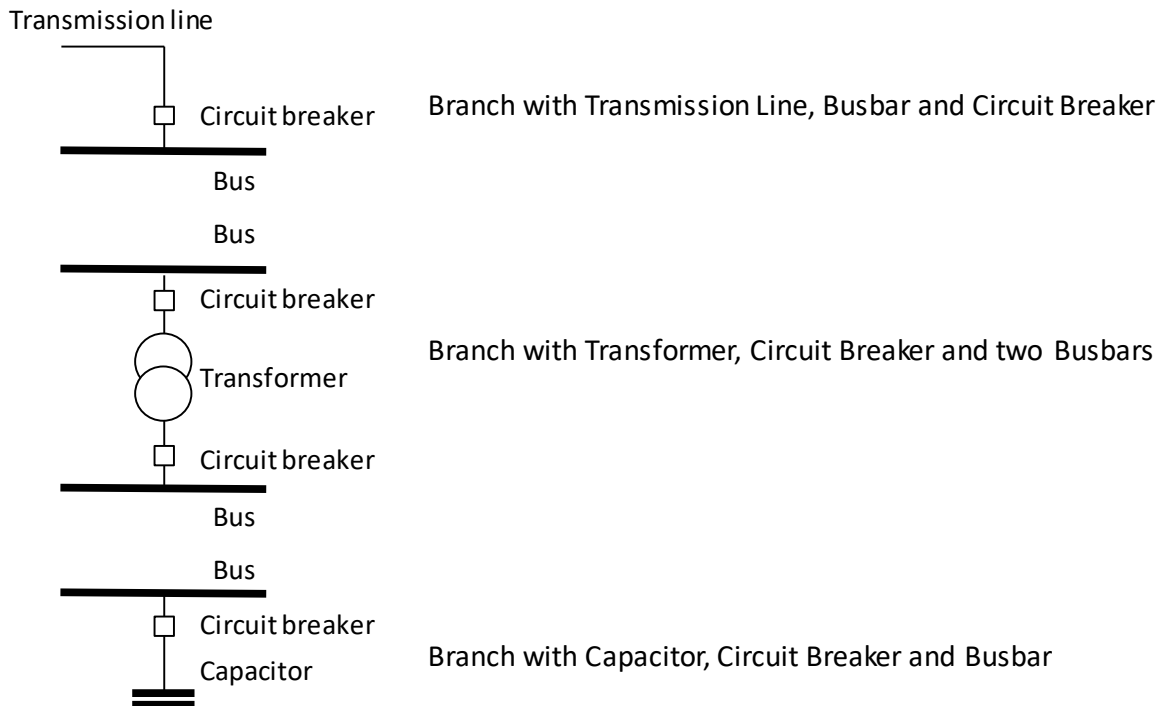

Worked Example 1: Substation costs priority ordering

Consider the substation in Figure 2 below with an ORC value of \$12 million. However \$3 million is for the existing negotiated service, which does not form part of the regulated asset base and is not governed by 6A.23.2 (d). Therefore, the negotiated service does not exist for the purposes of priority ordering, and the total infrastructure cost is \$9 million for allocation purposes.

Figure 2. Worked Example 1, Diagram A

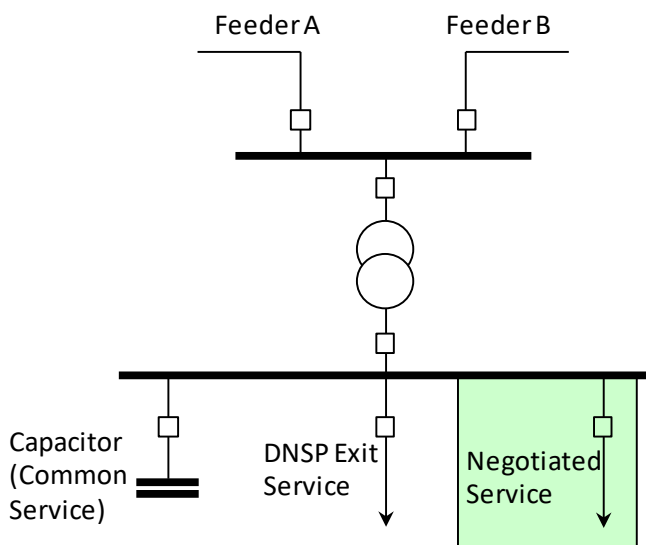

Step 1: The branches are Feeder A, Feeder B, DNSP Exit, Tie Transformer and Capacitor, the negotiated service branch is not considered as discussed above.

Step 2: The total number of circuit breakers directly connected to branches is 6 again excluding the negotiated service).

Step 3.1: The stand-alone arrangement for the provision of *prescribed TUOS services* to an equivalent standard is shown below and consists of 2 circuit breakers.

Figure 3. Worked Example 1, Diagram B

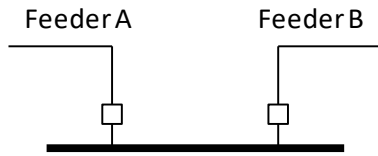

Step 3.2: The stand-alone arrangement for the provision of *prescribed common transmission services* to an equivalent standard is shown below and consists of 3 circuit breakers.

Figure 4. Worked Example 1, Diagram C

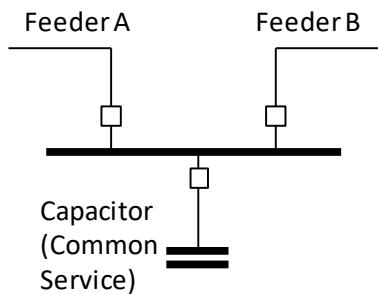

Step 4: Total infrastructure cost is \$9 million, excluding the negotiated service as discussed.

Costs are allocated to prescribed TUOS in the ratio of the circuit breakers in the stand-alone arrangement to the total circuit breakers.

Infrastructure Cost Allocated to TUOS = $(2/6) \times \$9m = \$3m$ Unallocated = $\$9m - \$3m = \$6m$.

Costs are allocated to prescribed common service in the ratio of the circuit breakers in the stand-alone arrangement to the total circuit breakers.

Infrastructure Cost allocated to Common Service: $(3/6) \times \$9m = \$4.5m$ Unallocated = $\$6m - \$4.5m = \$1.5m$.

Remainder of Unallocated (calculated above) to be allocated to *prescribed entry services* and *prescribed exit services*.

Infrastructure Cost allocated to Exit = \$1.5m.

This example is shown in Table 8.

Table 8. Priority ordering for Example 1

| Asset Class | Breakers | Allocation | Unallocated |
|-------------------------------------|----------|------------------------|-------------|
| Substation Infrastructure Costs | | \$9M | \$9M |
| Total Breakers | 6 | | |
| TUOS Stand Alone Breakers | 2 | | |
| 1. Share to prescribed TUOS | =2/6 | =2/6 x \$9M =\$3M | \$6M |
| Common Service Stand Alone Breakers | 3 | | |
| 2. Share to Common Service | =3/6 | =3/6 x \$9M =\$4.5M | \$1.5M |
| 3. Share to Entry and Exit Service | | =\$1.5M | 0 |

Worked Example 2: Subtransmission substation cost priority ordering

Consider the substation in Figure 5 below, where the secondary voltage is 66 kV (and therefore capable of providing support to the higher voltage transmission network).

Figure 5. Worked Example 2, Diagram A

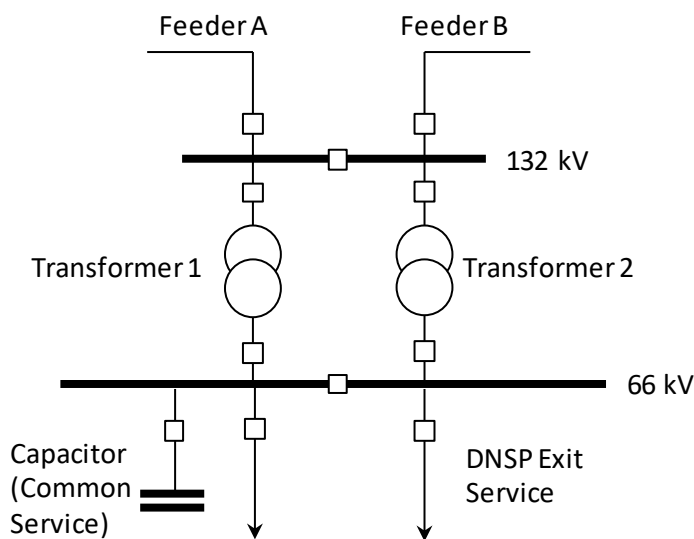

- Step 1:** The branches are Feeder A, Feeder B, DNSP Exit (2), Transformer 1, Transformer 2 and Capacitor.
- Step 2:** The total number of circuit breakers directly connected to branches is 9. The bus section breakers are not directly connected to any of the branches and are therefore ignored for the purposes of priority ordering.
- Step 3.1:** The stand-alone arrangement for the provision of *prescribed TUOS services* to an equivalent standard is shown below and consists of 2 circuit breakers. Note the bus section breaker is ignored since it is not connected to any of the branches.

Figure 6. Worked Example 2, Diagram B

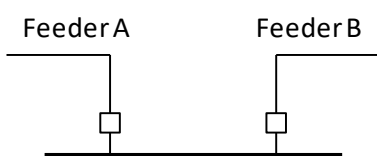

Step 3.2: The stand-alone arrangement for the provision of *prescribed common transmission services* to an equivalent standard is shown below and consists of 3 circuit breakers.

Figure 7. Worked Example 2, Diagram C

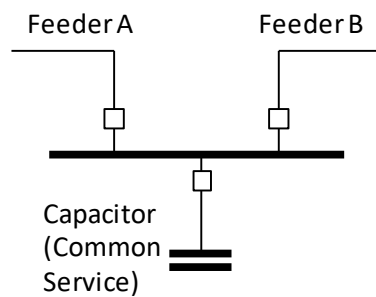

Step 4: Assume the total infrastructure cost is \$20 million.

Costs are allocated to prescribed TUOS in the ratio of the circuit breakers in the stand-alone arrangement to the total circuit breakers.

Infrastructure Cost Allocated to TUOS = $(2/9) \times \$20\text{m} = \4.44m Unallocated = $\$20\text{m} - \$4.44\text{m} = \$15.55\text{m}$.

Costs are allocated to prescribed common service in the ratio of the circuit breakers in the stand-alone arrangement to the total circuit breakers.

Infrastructure Cost allocated to Common Service: $(3/9) \times \$20\text{m} = \6.67m Unallocated = $\$15.55\text{m} - \$6.67\text{m} = \$8.89\text{m}$.

Remainder of Unallocated (calculated above) to be allocated to *prescribed entry services* and *prescribed exit services*.

Infrastructure Cost allocated to Exit = \$8.89m.

This allocation is shown in Table 9.

Table 9. Priority ordering for Example 2

| Asset Class | Breakers | Allocation | Unallocated |
|-------------------------------------|----------|--------------------------|-------------|
| Substation Infrastructure Costs | | \$20M | \$20M |
| Total Breakers | 9 | | |
| TUOS Stand Alone Breakers | 2 | | |
| 1. Share to prescribed TUOS | =2/9 | =2/9 x \$20M =\$4.44M | \$15.55M |
| Common Service Stand Alone Breakers | 3 | | |
| 2. Share to Common Service | =3/9 | =3/9 x \$20M =\$6.67M | \$8.89M |
| 3. Share to Entry and Exit Service | | =\$8.89M | 0 |

Worked Example 3: Cost priority ordering for 132/11 kV zone substations and 132/33 kV subtransmission substations

Where the secondary voltage of a substation forming part of the transmission network is less than 66 kV, the lower voltage assets are not capable of providing support to the higher voltage transmission network. Such assets provide exit services to the distribution network.

Consider the zone substation below, where the secondary voltage is 11 kV. The substation is considered to comprise two sections:

- The 132 kV section, which provides transmission support
- The transformers and 11 kV busbar, which supply the distribution system and provide a DNSP exit service.

Figure 8. Worked Example 3, Diagram A

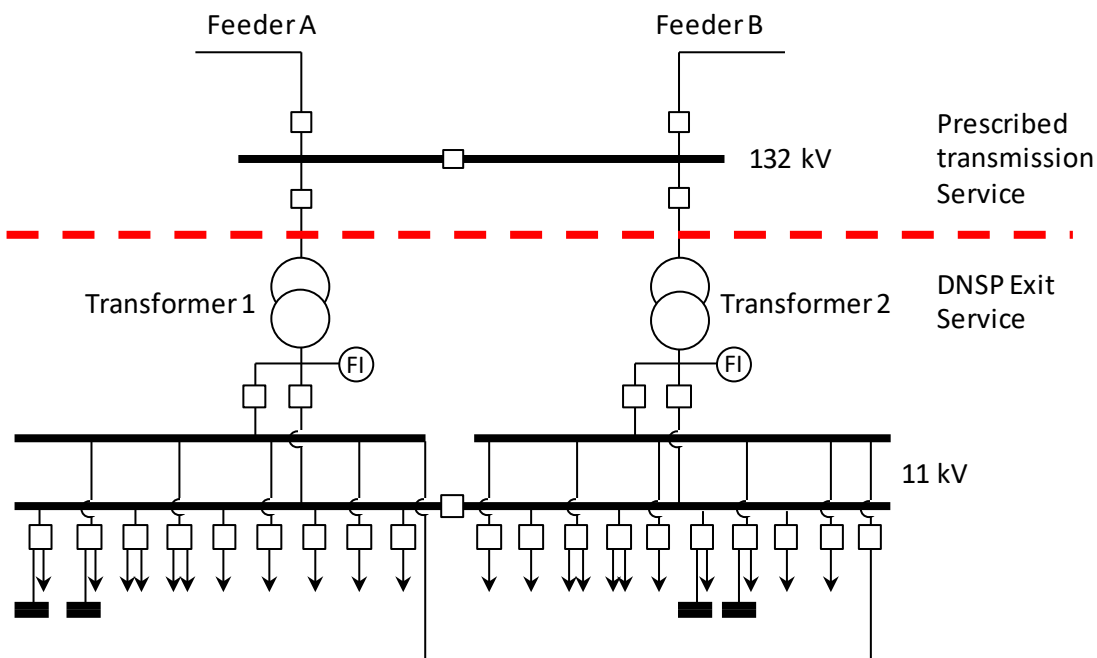

- Step 1:** The branches are Feeder A, Feeder B and DNSP Exit (Transformer 1 and Transformer 2).
- Step 2:** The total number of circuit breakers directly connected to branches is 4. The 132 kV bus section breaker is not directly connected to any of the branches and is therefore ignored for the purposes of priority ordering.
- Step 3.1:** The stand-alone arrangement for the provision of *prescribed TUOS services* to an equivalent standard is shown below and consists of 2 circuit breakers. Note the bus section breaker is ignored since it is not connected to any of the branches.

Figure 9. Worked Example 3, Diagram B

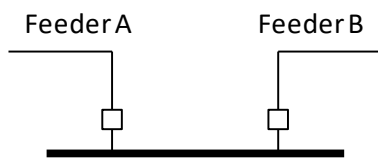

- Step 3.2:** There is no equipment providing common service at this location.
- Step 4:** Assume the total infrastructure cost is \$30 million, of which \$6 million is associated with the assets that provide transmission services and \$24 million associated with the distribution exit services (the 132/11 kV transformers and 11kV equipment).
- Costs are allocated to prescribed TUOS in the ratio of the circuit breakers in the stand-alone arrangement to the total circuit breakers.
- Infrastructure Cost Allocated to TUOS = $(2/4) \times \$6m = \$3.0m$ Unallocated = $\$6m - \$3m = \$3m$.
- There are no costs allocated to prescribed common service.
- Remainder of Unallocated (calculated above) to be allocated to *prescribed entry services* and *prescribed exit services*.
- Infrastructure Cost allocated to Exit = $\$3m + \$24m$ (see above) = $\$27m$.

This allocation is shown in Table 10.

Table 10. Priority ordering for Example 3

| Asset Class | Breakers | Allocation | Unallocated |
|-------------------------------------|----------|--------------------|-------------|
| Substation Infrastructure Costs | | \$6M | \$24M |
| Total Breakers | 4 | | |
| TUOS Stand Alone Breakers | 2 | | |
| 1. Share to prescribed TUOS | =2/4 | =2/4 x \$6M = \$3M | \$27M |
| Common Service Stand Alone Breakers | 0 | | |
| 2. Share to Common Service | 0 | 0 | \$27M |
| 3. Share to Entry and Exit Service | | = \$27M | 0 |