

# 2018-22

## POWERLINK QUEENSLAND REVENUE PROPOSAL

### APPENDIX 5.13 - PUBLIC

#### Powerlink Queensland Contingent Projects

© Copyright Powerlink Queensland 2016



Delivering better value

This page is left intentionally blank

## Table of Contents

1	SUMMARY .....	1
2	NORTH WEST SURAT BASIN AREA .....	3
3	CENTRAL TO NORTH QUEENSLAND REINFORCEMENT .....	6
4	SOUTHERN GALILEE BASIN CONNECTION SHARED NETWORK WORKS .....	9
5	NORTHERN BOWEN BASIN AREA .....	12
6	BOWEN INDUSTRIAL ESTATE .....	15
7	QNI UPGRADE (QUEENSLAND COMPONENT) .....	17
8	CENTRAL WEST TO GLADSTONE AREA REINFORCEMENT.....	21

# 1 Summary

This Appendix presents Powerlink Queensland's proposed contingent projects in accordance with clause 6A.8 of the National Electricity Rules (Rules). Pursuant to clause 6A.8.1(a) of the Rules Powerlink may include proposed contingent capital expenditure which Powerlink considers is reasonably required for the purpose of undertaking proposed contingent projects.

In accordance with clause 6A.8.1(b) of the Rules, the Australian Energy Regulator (AER) must accept proposed contingent projects where the AER is satisfied that:

- They are reasonably required to be undertaken in order to achieve the capital expenditure objectives;
- The proposed expenditure is not otherwise provided for (either in part or in whole) in the total of the forecast capital expenditure for the relevant regulatory period;
- The proposed expenditure reasonably reflects the capital expenditure criteria;
- The proposed expenditure exceeds either \$30m or 5% of the value of the maximum allowed revenue (MAR) for the first year of the regulatory period, whichever is the larger amount; and
- The trigger events for the proposed contingent projects are appropriate.

Contingent projects are therefore those which are significant, may arise in the period, but not yet committed and not provided for in the capital expenditure forecast for the relevant regulatory period. Such projects are linked to unique investment drivers such as a major point load rather than to general investment drivers (such as expectations of load growth within a region).

Powerlink engaged Ernst & Young (EY) to identify events that may trigger a material shift in either demand or generation and require additional prescribed network investment to occur prior to the end of the 2018-22 regulatory period.

In considering the EY report Powerlink has identified those projects that EY has rated as being Probable or Plausible to occur by 2022 as being potential contingent project triggers. EY defined Plausible and Probable as follows:

- Probable – The project has received required state/federal approvals (where applicable). It has the resources in place to proceed but is not publicly considered a committed project. There may be some speculation around the date of commencement.
- Plausible – The project may not have received final state and/or federal approvals but it has completed preliminary investigations and reports. There is likely some media attention surrounding the progress of the project. If the project gains momentum it is within reason that it could be operating before 2022.

Powerlink then analysed the impact of those probable and plausible projects on power transfers and assessed the adequacy of the network capability to meet the required needs. Where the capability of the prescribed network was forecast to be exceeded due to the changed needs expected network developments that could be required to meet those needs were identified. Where the estimated cost of the expected network development exceeds the contingent project cost threshold the project is proposed as a contingent project trigger.

By definition, it is not possible to accurately define the scope of proposed contingent projects at this early stage. Therefore, the proposed contingent projects are described by the most likely network development at the trigger level (the event which will result in a transmission network project of value in excess of the contingent project threshold). Detailed planning analyses, project scopes, cost estimates and regulatory investment test consultation will be required before any amendment to the revenue determination is considered by the AER should the specified trigger event for a proposed contingent project occur during the regulatory period.

Powerlink's proposed MAR for 2017/18 is \$767.4m (refer to Table 11.8 of Powerlink's 2018-22 Revenue Proposal). Five percent of the MAR is \$38.4m, which makes this amount the threshold for a contingent project for the purpose of Powerlink's Revenue Proposal. The following table summarises the indicative costs of the contingent projects detailed in this Appendix.

Project name	Indicative cost* \$m
North West Surat Basin Area	147.2
Central to North Queensland reinforcement	55.1
Southern Galilee Basin connection shared network works	116.9
Northern Bowen Basin area	55.7
Bowen industrial estate	42.9
Queensland/New South Wales Interconnector (QNI) upgrade (Queensland component)	66.7
Central West to Gladstone area reinforcement	105.5
Total indicative cost	590.0

\*Indicative cost (\$m, nominal) provided based on the expected network solution completed in 2021/22. Actual scope will be determined through a regulatory investment test should the trigger eventuate. There will also be a small incremental cost to operating expenditure.

## 2 North West Surat Basin Area

**Category:** Augmentation

**Indicative cost:** \$147.2m

### 2.1 Background

The North West region of the Surat Basin in South West Queensland is an area where significant increases in the demand and energy are plausible during the 2018-22 regulatory period. The most significant sources for this increased load include expansion to existing and development of new LNG extraction and processing facilities and development of a large scale coal mine and associated infrastructure.

Powerlink has recently established new 275/132kV substations at Columboola and Wandoan South and 275kV double circuit transmission lines from Western Downs to Columboola and Columboola to Wandoan South. Should additional loads connect in the area, the net import may exceed the firm capacity of these 275kV transmission lines and Powerlink would be unable to meet the reliability of supply obligations contained in its Transmission Authority.

### 2.2 Project overview

A feasible network solution to the identified voltage stability and future thermal limitations may involve the installation of a combination of Static VAR Compensators (SVCs) and/or the construction of 275kV transmission lines between Western Downs and Columboola, and between Columboola and Wandoan South substations.

For the purpose of this contingent project trigger it is assumed that this project comprises the construction of 275kV double circuit transmission lines between Western Downs and Columboola substations and between Columboola and Wandoan South substations, each with one side to be strung initially.

Powerlink considers the project should be accepted as a contingent project for the 2018-22 regulatory period because of uncertainty about the trigger event occurring and the scope and cost of the project.

### 2.3 Trigger event

EY identified several proposals for additional LNG upstream processing facilities and coal mining projects in the North West Surat Basin area. These loads could be up to an additional 350MW and cause network flows to reach thermal and/or voltage stability limitations and consequently impact supply reliability.

The load within this area predominately consists of electric motors. These take the form of many induction motors at the LNG wellheads for water extraction and low level compression and then much larger compression motors (often behind variable speed drives) at the major connection points.

Depending on the nature of this load response, as well as the size and location of additional load, voltage stability limitations may emerge prior to thermal limitations being reached on the 275kV network supplying the area. For voltage stability limitations the critical contingencies are outages of the 275kV circuits between Western Downs and Columboola, and between Columboola and Wandoan South substations. For thermal limitations the critical contingency is an outage between Columboola and Wandoan South substations.

Due to the nature of the voltage stability limitation, the size and location of load and the range of contingencies over which the instability may occur, it will not be possible to address this issue by installing a single SVC at a single location. To address the voltage stability limitation the following network options are viable:

- SVCs at both Columboola and Wandoan South substations;
- Additional circuits between Western Downs, Columboola and Wandoan South substations to increase fault level and transmission strength; or
- A combination of both.

The trigger for action occurs when the forecast net transfer on the transmission system to the North West Surat Basin area exceeds the thermal and/or voltage stability limit, taking into account existing and future generation including its availability and market dispatch and Powerlink's reliability of supply obligation contained in its Transmission Authority.

Powerlink proposes the following trigger events:

- Commitment of additional load in the north west Surat Basin area that results in forecast net transfer on the transmission system that exceeds the thermal and/or voltage stability limits;
- Successful completion of the Regulatory Investment Test for Transmission (RIT-T), including a comprehensive assessment of credible options, that demonstrates a network investment by Powerlink maximises the net market benefits while meeting Powerlink's reliability of supply obligations to the North West Surat Basin area; and
- Powerlink Board commitment to proceed with the project subject to the AER amending Powerlink's revenue determination pursuant to the Rules.

These triggers are appropriate in relation to the proposed contingent project in that they:

- Are specific and capable of objective verification and are all that is required for the revenue determination to be amended;
- Are of a nature that if they occur the undertaking of the proposed contingent project is reasonably necessary to achieve the capital expenditure objectives;
- Relate to a specific location or locations on the transmission network and not the transmission network as a whole; and
- Are probable but too uncertain to include the proposed contingent project in the capital expenditure forecast.

## 2.4 Project requirement

The expansion of coal and gas mining developments in the area will cause thermal and/or voltage stability limitations impacting supply reliability to the North West Surat Basin area. The existing transmission system is unable to accommodate this expansion within the requirements of Powerlink's Transmission Authority.

Both the timing and magnitude of the expansion projects and, therefore, the transmission requirements are uncertain at this time.

If the trigger events occur, the proposed contingent project would be reasonably required to meet the Rules capital expenditure objectives to efficiently meet expected demand for prescribed transmission services, comply with all applicable regulatory obligations associated with the provision of prescribed transmission services and maintain the quality, reliability and security of supply of prescribed services.

## 2.5 Contingent capital expenditure

The proposed contingent project is estimated to cost \$147.2m.

This estimate is based on the establishment of a double circuit 275kV transmission line, with one side strung, between Western Downs and Columboola substations and between Columboola and Wandoan South substations.

By definition, it is not possible to accurately define the scope of proposed contingent projects at this early stage. Detailed planning analyses, project scopes and cost estimates will be required before any amendment to the revenue determination is considered by the AER should the specified trigger event for the proposed contingent project occur during the 2018-22 regulatory period.

The forecast capital expenditure in Powerlink's Revenue Proposal does not include any allowance for projects overlapping in scope.

The estimated net contingent capital expenditure exceeds the contingent project threshold of \$38.4m.

## **2.6 Demonstration of Rules compliance**

Powerlink considers that the project should be accepted as a contingent project for the regulatory period as it is:

- a) Not otherwise provided for in the total forecast capital expenditure;
- b) Reasonably reflects the capital expenditure criteria, noting that the costs are an estimate at this point;
- c) Exceeds the contingent project threshold as set out in Section 2.5 above;
- d) Is reasonably required to achieve the capital expenditure objectives as set out in Section 2.4 above; and
- e) Has an appropriately defined trigger event as set out in Section 2.3 above.



## 3 Central to North Queensland Reinforcement

**Category:** Augmentation

**Indicative cost:** \$55.1m

### 3.1 Background

The Central West and North Queensland zones are areas where significant increases in the demand and energy are plausible during the 2018-22 regulatory period. The most significant sources for this increased load include, but may not be limited to, development of the LNG industry in the Northern Bowen Basin and development of large scale coal mines in the Galilee Basin and associated rail and port infrastructure.

Power transfer capability into northern Queensland is limited by thermal ratings or voltage stability limitations, depending on prevailing weather conditions and scheduled generation. Thermal limitations may occur on the Bouldercombe to Broadsound 275kV line following a critical contingency of a Stanwell to Broadsound 275kV circuit. Voltage stability limitations may occur following the trip of the Townsville gas turbine or following a contingency of a Stanwell to Broadsound 275kV circuit.

As demand increases in northern Queensland transmission congestion may occur, requiring northern Queensland generators to be constrained on. As generation costs are higher in northern Queensland due to reliance on liquid fuels, it may be economic to advance the timing of augmentation to deliver positive net market benefits. The additional load in northern Queensland that would trigger the network augmentation ahead of continued network support cost is approximately 340 MW.

### 3.2 Project overview

This proposed contingent project comprises the stringing of the 2nd circuit of an existing double circuit line between Stanwell and Broadsound that currently has only one side strung.

Powerlink considers that the project should be accepted as a contingent project for the 2018-22 regulatory period because of uncertainty about the trigger event occurring and the scope and cost of the project required to maintain reliability of supply.

### 3.3 Trigger event

Network analysis indicates that additional load in excess of approximately 340 MW connected to the Central West and/or North Queensland zones is required to trigger the proposed contingent project.

For the LNG industry, Arrow Energy has proposed to develop a gas project involving a phased expansion of CSG production to supply LNG for the export market and/or sell domestically. EY has identified that this project could increase demand in the northern Bowen Basin area by up to 80 MW.

The Galilee Basin, 320 – 450 km west of Mackay and Rockhampton, is the last remaining major coal province yet to be developed in Queensland. It is also an emerging asset with many significant energy related proposals including multiple coal mines, underground coal gasification, and oil and gas exploration.

Mining proponents in the Galilee Basin are proposing to develop several large scale coal mines, which would result in a substantial increase in electricity demand. The proposed mines include:

- Carmichael Coal and Rail Project (Adani Group);
- Alpha Coal Project (joint venture GVK and Hancock Prospecting Pty Ltd);
- Kevin's Corner Mine (joint venture GVK and Hancock Prospecting Pty Ltd); and
- China First Project (Waratah Coal).

The Carmichael Coal and Rail project has stated it could demand up to 200 MW of supply from the transmission network from a connection to Powerlink's Strathmore Substation near Collinsville.<sup>1</sup> Alpha Coal (135 MW), Kevin's Corner (250 MW) and China First (150 MW) coal mines are located towards the southern end of the Galilee Basin. These projects could demand up to 535 MW of supply from the transmission network from a connection to Powerlink's Lilyvale Substation in Central West Queensland.

These plausible load developments would increase the required power transfers between Central Queensland and North Queensland beyond the limits of the existing transmission network.

Powerlink proposes the following trigger events:

- Commitment of additional load to be connected to the Central West and/or North Queensland zones that requires the dispatch of higher cost generation in northern Queensland to maintain power transfers within limits;<sup>2</sup>
- Successful completion of the RIT-T, including a comprehensive assessment of credible options, that demonstrates a network investment by Powerlink maximises the net market benefits while meeting Powerlink's reliability of supply obligations to North Queensland;
- Determination by the AER under clause 5.16.6 of the Rules that the proposed investment satisfies the RIT-T; and
- Powerlink Board commitment to proceed with the project subject to the AER amending Powerlink's revenue determination pursuant to the Rules.

These triggers are appropriate in relation to the proposed contingent project in that they:

- Are specific and capable of objective verification and are all that is required for the revenue determination to be amended;
- Are of a nature that if they occur the undertaking of the proposed contingent project is reasonably necessary to achieve the capital expenditure objectives;
- Relate to a specific location or locations on the transmission network and not the transmission network as a whole; and
- Are probable but too uncertain to include the proposed contingent project in the capital expenditure forecast.

### 3.4 Project requirement

Expansion in the Galilee Basin and the Northern Bowen Basin is expected to add load to a level that will require increasing reliance on more expensive generation in northern Queensland in order to maintain a reliable electricity supply.

Both the timing and magnitude of the expansion project and, therefore, the transmission requirements are uncertain at this time.

If the trigger event occurs the proposed contingent project would be reasonably required to meet the Rules capital expenditure objectives to efficiently meet expected demand for prescribed transmission services, comply with all applicable regulatory obligations associated with the provision of prescribed transmission services and maintain the quality, reliability and security of supply of prescribed services.

### 3.5 Contingent capital expenditure

The proposed contingent project is estimated to cost \$55.1m.

This estimate is based on stringing the second side of an existing 275kV double circuit steel tower line between Stanwell and Broadsound substations.

---

<sup>1</sup> In May 2014 the Queensland Co-ordinator General's report on the project's Environmental Impact Statement (EIS) gave environmental approval for the Carmichael Coal and Rail project subject to conditions. In October 2015, the Commonwealth Minister for the Environment gave approval for the project under the Environmental Protection and Biodiversity Conservation Act, subject to conditions.

<sup>2</sup> That is, "out-of-merit" generation either through network support arrangements or constrained / directed on by AEMO.

By definition, it is not possible to accurately define the scope of proposed contingent projects at this early stage. Detailed planning analyses, project scopes and cost estimates will be required before any amendment to the revenue determination is considered by the AER should the specified trigger event for a proposed contingent project occur during the 2018-22 regulatory period.

The forecast capital expenditure in Powerlink's Revenue Proposal does not include any allowance for projects overlapping in scope.

The estimated net contingent capital expenditure exceeds the contingent project threshold of \$38.4m.

### **3.6 Demonstration of Rules compliance**

Powerlink considers that the project should be accepted as a contingent project for the 2018-22 regulatory period as it is:

- a) Not otherwise provided for in the total forecast capital expenditure;
- b) Reasonably reflects the capital expenditure criteria, noting that the costs are an estimate at this point;
- c) Exceeds the contingent project threshold as set out in Section 3.5 above;
- d) Is reasonably required to achieve the capital expenditure objectives as set out in Section 3.4 above; and
- e) Has an appropriately defined trigger event as set out in Section 3.3 above.

## 4 Southern Galilee Basin Connection Shared Network Works

**Category:** Augmentation

**Indicative cost:** \$116.9m

### 4.1 Background

The southern area of the Galilee Basin, 450 km west of Rockhampton, is part of the last remaining major coal province yet to be developed in Queensland. It is also an emerging asset with many significant energy related proposals including multiple coal mines, underground coal gasification and oil and gas exploration.

Primary transmission supply to the area is currently from two 275kV single circuit lines supplying Lilyvale Substation from Broadsound Substation.

### 4.2 Project overview

This proposed contingent project comprises:

- Paralleling of the two existing Broadsound to Lilyvale 275kV single circuit feeders; and
- Construction of 109km 275kV double circuit transmission line, single side strung, between Broadsound and Lilyvale substations.

The stringing of the 2nd circuit of the existing double circuit line, single side strung, between Stanwell and Broadsound will also be required if not already triggered by additional load in northern Queensland as described in Section 3 above.

Powerlink considers that the project should be accepted as a contingent project for the 2018-22 regulatory period because of uncertainty about the trigger event occurring and the scope and cost of the projects required to maintain reliability of supply.

### 4.3 Trigger event

Network analysis demonstrates that an additional load in excess of 195MW supplied from Lilyvale Substation is required to trigger the proposed contingent project. EY identified a number of plausible projects that would exceed this level of additional load.

Mining proponents in the Galilee Basin are proposing to develop several large scale coal mines in the region, which would result in a substantial increase in electricity demand.

Several major export coal mine proposals located in the southern area of the Galilee Basin have secured Federal environmental approvals:

- Alpha Coal Project (joint venture GVK and Hancock Prospecting Pty Ltd);
- Kevin's Corner Mine (joint venture GVK and Hancock Prospecting Pty Ltd); and
- China First Project (Waratah Coal).

The Alpha Coal project plans on sharing its railway infrastructure with the Kevin's Corner Mine. This suggests a reliance on splitting infrastructure costs between the two projects. If one of these projects were to proceed, then the other is likely to follow. Given the extensive transmission and rail infrastructure development needed for the Galilee Basin projects to proceed, it is likely that if one proceeds, more may follow to fully utilise the investment.

If one or more projects proceed it is expected that the growth in electricity demand will exceed the capability of the transmission network currently servicing the region. Therefore, to meet this emerging demand growth, Powerlink may need to reinforce its existing network to service the future developments in this area.

Powerlink proposes the following trigger events:

- Commitment of additional load in excess of 195 MW to be supplied from the Lilyvale Substation;
- Successful completion of the RIT-T, including a comprehensive assessment of credible options, that demonstrates a network investment by Powerlink maximises the net market benefits while meeting reliability of supply obligations to North Queensland; and
- Powerlink Board commitment to proceed with the project subject to the AER amending Powerlink's revenue determination pursuant to the Rules.

These triggers are appropriate in relation to the proposed contingent project in that they:

- Are specific and capable of objective verification and are all that is required for the revenue determination to be amended;
- Are of a nature that if they occur the undertaking of the proposed contingent project is reasonably necessary to achieve the capital expenditure objectives;
- Relate to a specific location or locations on the transmission network and not the transmission network as a whole; and
- Are probable but too uncertain to include the proposed contingent project in the capital expenditure forecast.

#### **4.4 Project requirement**

Expansion in the Galilee Basin is expected to add load in excess of the trigger event level. The existing transmission system is unable to accommodate this expansion within the requirements of Powerlink's Transmission Authority.

Both the timing and magnitude of the expansion project and, therefore, the transmission requirements are uncertain at this time.

If the trigger event occurs the proposed contingent project would be reasonably required to meet the Rules capital expenditure objectives to efficiently meet expected demand for prescribed transmission services, comply with all applicable regulatory obligations associated with the provision of prescribed transmission services and maintain the quality, reliability and security of supply of prescribed services.

#### **4.5 Contingent capital expenditure**

The proposed contingent project is estimated to cost \$116.9m.

This estimate is based on the establishment of a double circuit 275kV transmission line, with one side strung, between Broadsound and Lilyvale substations.

By definition, it is not possible to accurately define the scope of proposed contingent projects at this early stage. Detailed planning analyses, project scopes and cost estimates will be required before any amendment to the revenue determination is considered by the AER should the specified trigger event for a proposed contingent project occur during the 2018-22 regulatory period. In particular, the above cost does not include the cost of stringing the 2nd circuit of the existing Stanwell – Broadsound line. This additional cost may need to be included if the Southern Galilee Basin contingent project is triggered prior the Central to North Queensland contingent project.

The forecast capital expenditure in Powerlink's Revenue Proposal does not include any allowance for projects overlapping in scope.

The estimated net contingent capital expenditure exceeds the contingent project threshold of \$38.4m.

## 4.6 Demonstration of Rules compliance

Powerlink considers that the project should be accepted as a contingent project for the 2018-22 regulatory period as it is:

- a) Not otherwise provided for in the total forecast capital expenditure;
- b) Reasonably reflects the capital expenditure criteria, noting that the costs are an estimate at this point;
- c) Exceeds the contingent project threshold as set out in Section 4.5 above;
- d) Is reasonably required to achieve the capital expenditure objectives as set out in Section 4.4 above; and
- e) Has an appropriately defined trigger event as set out in Section 4.3 above.

## 5 Northern Bowen Basin Area

**Category:** Augmentation

**Indicative cost:** \$55.7m

### 5.1 Background

The existing load in the Northern Bowen Basin in the Moranbah area primarily relates to the mining and transportation of coal. The load is concentrated in a band between Newlands and Dysart, which corresponds to a particularly productive coal seam that supplies around half the world's high quality metallurgical coal. With the establishment of LNG export facilities at Gladstone there is increased interest in further developing the coal seam gas reserves in the Northern Bowen Basin to supply the export market and/or sell domestically.

The Northern Bowen Basin transmission network comprises the 132kV network south from Strathmore 275kV Substation (excluding the 132kV circuits to Proserpine), west from Nebo 275kV Substation and north from Lilyvale 275kV Substation. Moranbah is the point at which the 132kV circuits from Strathmore, Nebo and Lilyvale intersect, and presently supplies the largest load in the area. The existing transmission network is illustrated below.

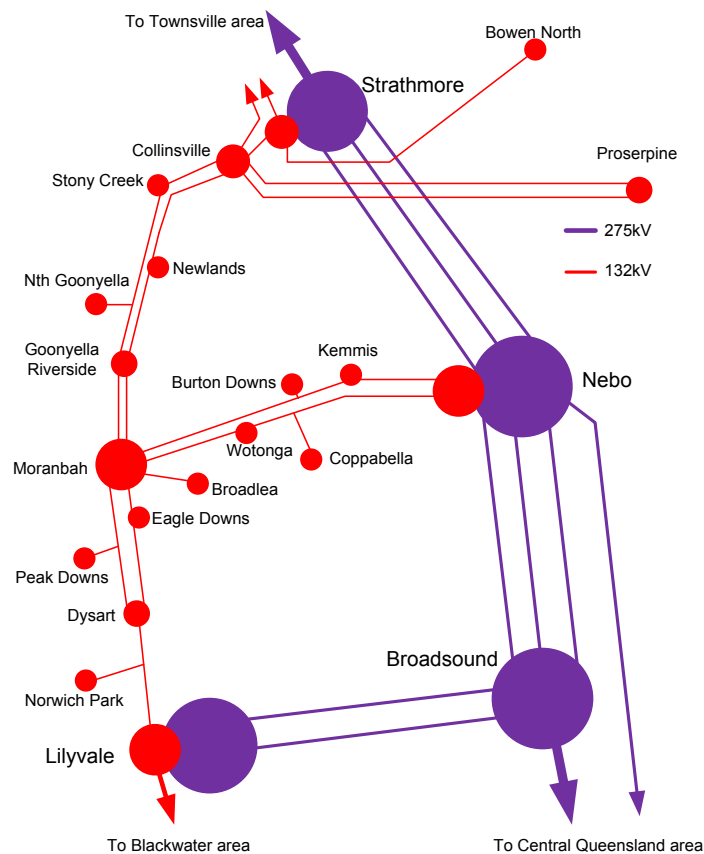

## 5.2 Project overview

The proposed contingent project comprises:

- Establishment of a second 275/132kV transformer at Strathmore Substation;
- Switching the Collinsville to Clare South 132kV circuit at Strathmore Substation to provide a second Strathmore to Collinsville 132kV circuit; and
- Establishing 132kV phase shifting transformers at an already established site between Moranbah and Collinsville.

Powerlink considers that the project should be accepted as a contingent project for the 2018-22 regulatory period because of uncertainty about the trigger event occurring and the scope and cost of the project.

## 5.3 Trigger event

Network analysis demonstrates that an additional load in excess of 30MW connected to the network between Moranbah and Collinsville is required to trigger the proposed contingent project.

Arrow Energy has proposed to develop a gas project involving a phased expansion of CSG production to supply LNG for the export market and/or sell domestically. EY identified that this project could increase demand in the area between Moranbah and Collinsville by up to 80MW.

If additional load is to be supplied between Moranbah and Collinsville substations, including supply directly from either of those substations, it is expected that electricity demand will exceed the capability of the transmission network currently servicing the region. Therefore, to meet this emerging demand growth, Powerlink may need to reinforce its existing network to reliably service the future developments in the area.

Powerlink proposes the following trigger events:

- Commitment of additional load in excess of 30MW to be supplied from the network between Moranbah and Collinsville 132kV substations, including supply directly from either of these substations;
- Successful completion of the RIT-T, including a comprehensive assessment of the credible options, that demonstrates a network investment by Powerlink maximises the net market benefits while meeting reliability of supply obligations to the Northern Bowen Basin area; and
- Powerlink Board commitment to proceed with the project subject to the AER amending Powerlink's revenue determination pursuant to the Rules.

These triggers are appropriate in relation to the proposed contingent project in that they:

- Are specific and capable of objective verification and are all that is required for the revenue determination to be amended;
- Are of a nature that if they occur the undertaking of the proposed contingent project is reasonably necessary to achieve the capital expenditure objectives;
- Relate to a specific location or locations on the transmission network and not the transmission network as a whole; and
- Are probable but too uncertain to include the proposed contingent project in the capital expenditure forecast.



## 5.4 Project requirement

Expansion of existing loads and/or addition of new loads in the Northern Bowen Basin is expected to add load in excess of the trigger event level. The existing transmission network is unable to accommodate this expansion within the requirements of the Powerlink's Transmission Authority.

Both the timing and magnitude of the expansion project and, therefore, the transmission requirements are uncertain at this time.

If the trigger event occurs the proposed contingent project would be reasonably required to meet the Rules capital expenditure objectives to efficiently meet expected demand for prescribed transmission services, comply with all applicable regulatory obligations associated with the provision of prescribed transmission services and maintain the quality, reliability and security of supply of prescribed services.

## 5.5 Contingent capital expenditure

The proposed contingent project is estimated to cost \$55.7m.

This estimate is based on establishment of a second 275/132kV transformer at Strathmore Substation, establishment of phase shifting transformers on the circuits between Moranbah and Collinsville substations and additional line switching at Strathmore to establish a second Strathmore to Collinsville 132kV circuit.

By definition, it is not possible to accurately define the scope of proposed contingent projects at this early stage. Detailed planning analyses, project scopes and cost estimates will be required before any amendment to the revenue determination is considered by the AER should the specified trigger event for a proposed contingent project occur during the regulatory period.

The forecast capital expenditure in Powerlink's Revenue Proposal does not include any allowance for projects overlapping in scope.

The estimated net contingent capital expenditure exceeds the contingent project threshold of \$38.4m.

## 5.6 Demonstration of Rules compliance

Powerlink considers that the project should be accepted as a contingent project for the 2018-22 regulatory period as it is:

- a) Not otherwise provided for in the total forecast capital expenditure;
- b) Reasonably reflects the capital expenditure criteria, noting that the costs are an estimate at this point;
- c) Exceeds the contingent project threshold as set out in Section 5.5 above;
- d) Is reasonably required to achieve the capital expenditure objectives as set out in Section 5.4 above; and
- e) Has an appropriately defined trigger event as set out in Section 5.3 above.

## 6 Bowen Industrial Estate

**Category:** Augmentation

**Indicative cost:** \$42.9m

### 6.1 Background

Electricity demand in the Abbot Point State Development Area (SDA) is associated with infrastructure for new and expanded mining export and value adding facilities. Located approximately 20 kilometres west of Bowen, Abbot Point forms a key part of the infrastructure that will be necessary to support the development of coal exports from the northern part of the Galilee Basin.

The Abbot Point area is supplied at 66kV from Powerlink's Bowen North substation. Bowen North Substation was established in 2010 with a single 132/66kV transformer and supplied from a double circuit 132kV line from Strathmore Substation but with only a single circuit connected. During outages of the single supply to Bowen North the load is supplied via the Ergon Energy 66kV network from Proserpine, some 60km to the south.

### 6.2 Project overview

The proposed contingent project comprises:

- Installation of a second 132/66kV transformer at Bowen North Substation;
- Connection of the second Strathmore to Bowen North 132kV circuit;
- Establishment of a second 275/132kV transformer at Strathmore Substation;
- Switching the Collinsville to Clare South 132kV circuit at Strathmore Substation to provide a second Strathmore to Collinsville 132kV circuit; and

Powerlink considers that the project should be accepted as a contingent project for the regulatory period because of uncertainty about the trigger event occurring and the scope and cost of the project.

### 6.3 Trigger event

Network analysis demonstrates that an additional load in excess of 10MW supplied from Bowen North Substation is required to trigger the proposed contingent project. EY identified expansion of the Abbot Point coal terminal as a plausible project that could exceed this level of additional load.

Powerlink proposes the following trigger events:

- Commitment of additional load in excess of 10MW to be supplied from Bowen North Substation;
- Successful completion of the RIT-T, including a comprehensive assessment of the credible options, that demonstrates a network investment by Powerlink maximises the net market benefits while meeting reliability of supply obligations to the Bowen area; and
- Powerlink Board commitment to proceed with the project subject to the AER amending Powerlink's revenue determination pursuant to the Rules.

These triggers are appropriate in relation to the proposed contingent project in that they:

- Are specific and capable of objective verification and are all that is required for the revenue determination to be amended;
- Are of a nature that if they occur the undertaking of the proposed contingent project is reasonably necessary to achieve the capital expenditure objectives;
- Relate to a specific location or locations on the transmission network and not the transmission network as a whole; and
- Are probable but too uncertain to include the proposed contingent project in the capital expenditure forecast.

## 6.4 Project requirement

Expansion in the Abbot Point SDA is expected to add load in excess of the trigger event level. The existing transmission system is unable to accommodate this expansion within the requirements of Powerlink's Transmission Authority.

Both the timing and magnitude of the expansion project and, therefore, the transmission requirements are uncertain at this time.

If the trigger event occurs the proposed contingent project would be reasonably required to meet the Rules capital expenditure objectives to efficiently meet expected demand for prescribed transmission services, comply with all applicable regulatory obligations associated with the provision of prescribed transmission services and maintain the quality, reliability and security of supply of prescribed services.

## 6.5 Contingent capital expenditure

The proposed contingent project is estimated to cost \$42.9m.

This estimate is based on establishment a second 132kV circuit from Strathmore Substation to Bowen North Substation and a second 132/66kV transformer at Bowen North together with a second 275/132kV transformer and additional 132kV line switching at Strathmore.

By definition, it is not possible to accurately define the scope of proposed contingent projects at this early stage. Detailed planning analyses, project scopes and cost estimates will be required before any amendment to the revenue determination is considered by the AER should the specified trigger event for a proposed contingent project occur during the regulatory period.

The forecast capital expenditure in Powerlink's Revenue Proposal does not include any allowance for projects overlapping in scope.

The estimated net contingent capital expenditure exceeds the contingent project threshold of \$38.4m.

## 6.6 Demonstration of Rules compliance

Powerlink considers that the project should be accepted as a contingent project for the regulatory period as it is:

- a) Not otherwise provided for in the total forecast capital expenditure;
- b) Reasonably reflects the capital expenditure criteria, noting that the costs are an estimate at this point;
- c) Exceeds the contingent project threshold as set out in Section 6.5 above;
- d) Is reasonably required to achieve the capital expenditure objectives as set out in Section 6.4 above; and
- e) Has an appropriately defined trigger event as set out in Section 6.3 above.

## 7 QNI Upgrade (Queensland Component)

**Category:** Augmentation

**Indicative cost:** \$66.7m

### 7.1 Background

Since QNI was commissioned in 2001, a number of studies have been carried out by Powerlink and TransGrid to assess the technical and economic viability of increasing the power transfer capability in both directions.

The most recent assessment was carried out as part of the joint Powerlink and TransGrid regulatory consultation process commencing in late 2012. The formal RIT-T consultation process was finalised in December 2014 following the publication of the QNI Upgrade Project Assessment Conclusions Report (PACR) and completion of the mandatory consultation period. The PACR described the outcomes of a detailed technical and economic assessment into the upgrade of QNI.

The technical and economic benefits of potential QNI upgrade options were assessed across a range of market development scenarios broadly aligned with scenarios developed by AEMO for its 2012 National Transmission Network Development Plan (NTNDP). These scenarios reflected different levels of economic growth, industrial energy demand, rooftop PV penetration, energy efficiency and small non-scheduled generation. The AEMO core scenarios adopted for this RIT-T assessment include its 'Planning', 'Fast World Recovery' and 'Slow Rate of Change' scenarios.

As a result, the assessment concluded that while there were market benefits arising from an upgrade of the interconnector, the optimal timing and ranking of QNI upgrade options varied considerably across different market development scenarios and that there was no upgrade option which was consistently and robustly ranked above the "do nothing" option for the majority of the scenarios.

Therefore, in light of uncertainties surrounding these factors, Powerlink and TransGrid considered that it was prudent not to recommend a preferred upgrade option at that stage and to continue monitoring market developments to determine if any material changes could warrant reassessment of an upgrade to QNI.

### 7.2 Project overview

Powerlink and TransGrid have conducted studies for a number of years to assess market benefits from upgrading the QNI. Each assessment has been made in accordance with the relevant Regulatory Investment Test of the time.

If a technical and economic case can be made to upgrade the QNI capacity in the future, then the option selected will be the credible option (network and/or non-network) that maximises the present value of net economic benefit to all those who produce, consume and transport electricity in the market. The scope of credible network options will be developed at the time and may range from incremental upgrades to large scale upgrades. The outcome of the analysis across a broad range of market scenarios will conclude which option maximises the benefit.

The following figure shows a technically viable network option that would increase the QNI power transfer capability and satisfy the requirements of the NER Clause 6A.8.1 for contingent project expenditure. This network option establishes controllable series compensation (shaded in grey). This network option does not pre-empt the outcome of the RIT-T process however it does demonstrate a technically viable option that satisfies the requirements of the Rules for contingent project expenditure.

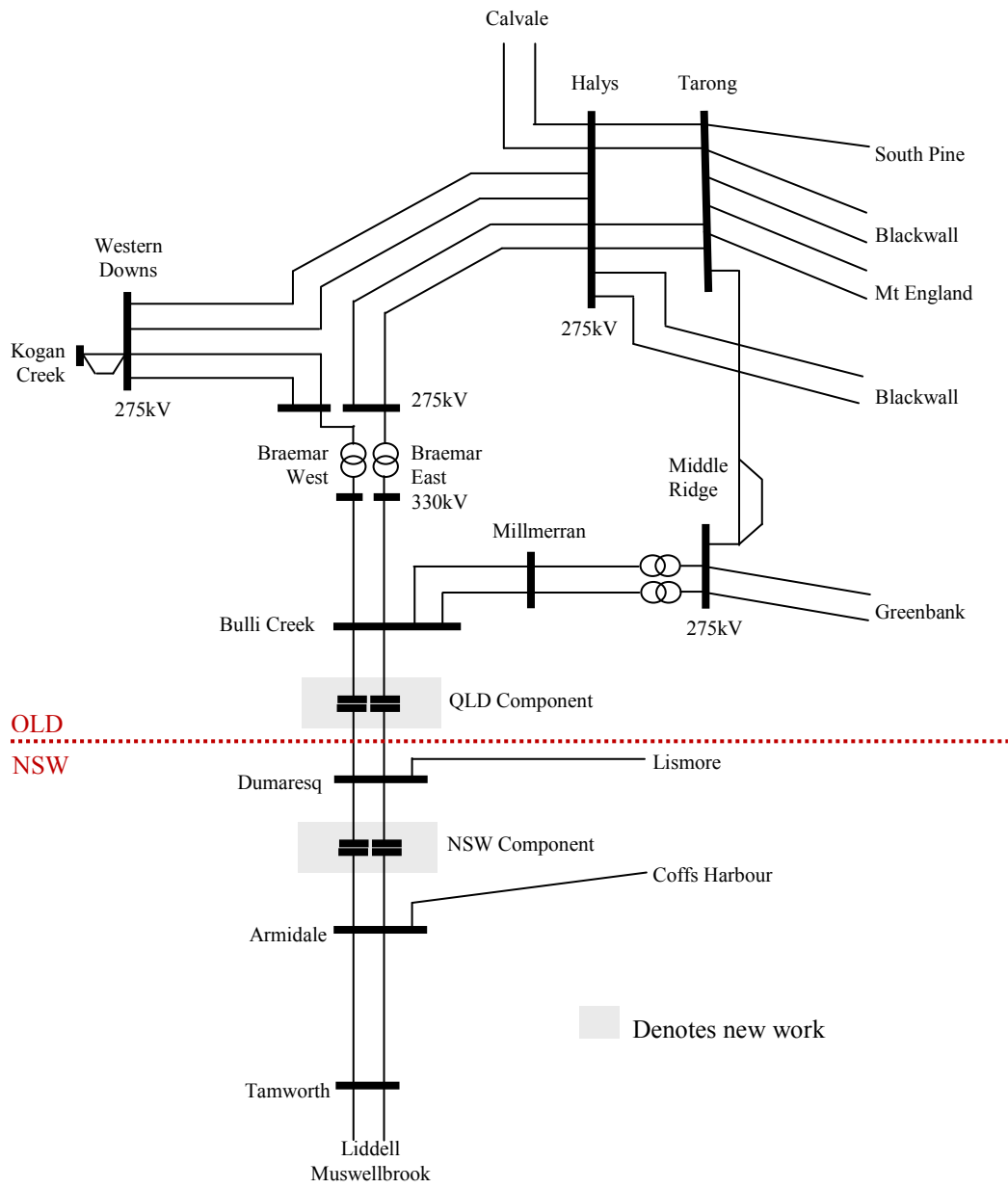

## 7.3 Trigger event

EY identified plausible developments in the Queensland region that may impact the demand for services on QNI. As a result there is a likely need to reassess the technical and economic viability of upgrading QNI consistent with the requirements of the RIT-T.

Powerlink proposes the following trigger events:

- Successful completion of the RIT-T demonstrating a network investment by Powerlink maximises the net market benefits from increasing the capacity of QNI either northward or southward or in both directions;
- Determination by the AER under clause 5.16.6 of the Rules that the proposed investment satisfies the RIT-T; and
- Powerlink Board commitment to proceed with the project subject to the AER amending Powerlink's revenue determination pursuant to the Rules.

These triggers are appropriate in relation to the proposed contingent project in that they:

- Are specific and capable of objective verification and are all that is required for the revenue determination to be amended;
- Are of a nature that if they occur the undertaking of the proposed contingent project is reasonably necessary to achieve the capital expenditure objectives;
- Relate to a specific location or locations on the transmission network and not the transmission network as a whole; and
- Are probable but too uncertain to include the proposed contingent project in the capital expenditure forecast.

## 7.4 Project requirement

The analyses for the RIT-T completed in December 2014 concluded that the main source of market benefits was due to the displacement of relatively higher cost generating plant located in the Queensland region with lower cost generating sources from the southern states. However, the analyses also found that the magnitude of market benefits were sensitive to a number of parameters contained within each of the market development scenarios, which affected the optimal timing and ranking of the upgrade options. These parameters include:

- Load and energy growth across the National Electricity Market (NEM);
- Future gas prices within Queensland;
- Development of wind farms within the northern NSW area; and
- Possible retirement of Redbank Power Station (now removed from service from August 2014 due to shut down).

In the context of load and energy growth in the NEM, EY identified a number of plausible load developments that may progress in the Queensland region within the 2018-22 regulatory period. In addition, EY identified plausible retirements of existing generation in the Queensland region.

Countering changes that result in a reduced supply capacity relative to demand in the Queensland region, EY identified plausible and probable additions in new supply capacity that may occur, within the Queensland region, during the next regulatory period. Coupled with the publically announced withdrawal of approximately 3,500MW of installed capacity in the southern states of the NEM southerly power transfers across QNI may become a limitation in the future.

The impact all this may have on the utilisation and incidence of constraints on QNI is complex and varied. Depending on the emergence of these changes QNI utilisation may increase in the northerly or southerly direction. The different investments in load and investments and de-investments in generation across the NEM may also impact on the scope of viable network upgrade options.

Both Powerlink and TransGrid will continue to monitor market developments for changes in investment and/or de-investment that may impact the technical and economic viability of upgrading QNI capacity and initiate a RIT-T as appropriate.

## **7.5 Contingent capital expenditure**

The proposed contingent project is estimated to cost \$66.7m.

This estimate is based on establishing series capacitors at a new site located with Queensland between Powerlink's Bulli Creek Substation and TransGrid's Dumaresq Substation. It does not include any costs for works within New South Wales on the TransGrid network.

By definition, it is not possible to accurately define the scope of proposed contingent projects at this early stage. Detailed planning analyses, project scopes and cost estimates will be required before any amendment to the revenue determination is considered by the AER should the specified trigger event for a proposed contingent project occur during the 2018-22 regulatory period.

The forecast capital expenditure in Powerlink's Revenue Proposal does not include any allowance for this project.

The estimated net contingent capital expenditure exceeds the contingent project threshold of \$38.4m.

## **7.6 Demonstration of Rules compliance**

Powerlink considers that the project should be accepted as a contingent project for the regulatory period as it is:

- a) Not otherwise provided for in the total forecast capital expenditure;
- b) Reasonably reflects the capital expenditure criteria, noting that the costs are an estimate at this point;
- c) Exceeds the contingent project threshold as set out in Section 7.5 above;
- d) Is reasonably required to achieve the capital expenditure objectives as set out in Section 7.4 above; and
- e) Has an appropriately defined trigger event as set out in Section 7.3 above.

## 8 Central West to Gladstone Area Reinforcement

**Category:** Augmentation

**Indicative cost:** \$105.5m

### 8.1 Background

Large parts of the existing 275kV network between the Central West and Gladstone zones were built with low capacity single conductor design in the late 70s and early 80s, coinciding with the establishment of the Gladstone Power Station. Additional transmission lines were developed in the late 80s and early 90s with the commissioning of the Callide B and Stanwell Power Stations and the establishment of Wurdong substation. Although these later lines have a higher rating they were still constructed with a single conductor per phase. In 2013, in response to an emerging reliability limitation the 275kV network was augmented by commissioning a double circuit (twin conductor per phase) 275kV line between Calvale and Stanwell substations.

This resultant 275kV network forms a triangle between the generation rich nodes of Calvale, Stanwell and Calliope River substations. This triangle delivers power to the major 275/132kV injection points of Calvale, Bouldercombe (Rockhampton), Calliope River (Gladstone) and Boyne Island Smelter (BSL) substations.<sup>3</sup>

Since there is a surplus of generation within this area, this network is pivotal to supply power to northern and southern Queensland. As such, the utilisation of this 275kV network depends not only on the generation dispatch and supply and demand balance within the Central West and Gladstone zones, but also on the demand levels and generation dispatch in northern and southern Queensland.

EY identified plausible developments in the Queensland region that would change not only the power transfer requirements between the Central West and Gladstone zones but also on the intra-connectors to northern and southern Queensland. These may lead to limitations within this 275kV triangle. Network limitations would need to be addressed by dispatching out-of-merit generation. In addition, Powerlink is aware of other potential developments that would significantly affect the loading on this network. These include:

[REDACTED]

Therefore, in light of uncertainties surrounding these factors, Powerlink considers that it is prudent to monitor the performance of the Central West zone to Gladstone zone network and the impact it may have on efficient market outcomes.

### 8.2 Project overview

This project involves the construction of a double circuit 275kV line between Calvale and Larcom Creek substations and the rebuild of the single circuit low capacity 275kV line between Larcom Creek and Calliope River substations.

Powerlink considers that the project should be accepted as a contingent project for the regulatory period because of uncertainty about the trigger event occurring and the scope and cost of the project.

<sup>3</sup> The 132kV sub-transmission system provides supply to bulk supply points within the Gladstone zone (including BSL, Queensland Alumina Limited (QAL) and Gladstone south) and the inland Bowen Basin coal mines at Blackwater and Moura.

<sup>4</sup> [REDACTED]



### 8.3 Trigger event

Plausible developments in the Queensland region identified by EY, and confidentially by Powerlink, that impact the demand for services on this network and there is a likely need to assess the technical and economic viability of upgrading its power transfer capacity with the requirements of the RIT-T.

Powerlink proposes the following trigger events:

- Successful completion of the RIT-T demonstrating a network investment by Powerlink maximises the net market benefits from increasing the capacity the 275kV network between the Central West and Gladstone zones;
- Determination by the AER under clause 5.16.6 of the Rules that the proposed investment satisfies the RIT-T; and
- Powerlink Board commitment to proceed with the project subject to the AER amending Powerlink's revenue determination pursuant to the Rules.

These triggers are appropriate in relation to the proposed contingent project in that they:

- Are specific and capable of objective verification and are all that is required for the revenue determination to be amended;
- Are of a nature that if they occur the undertaking of the proposed contingent project is reasonably necessary to achieve the capital expenditure objectives;
- Relate to a specific location or locations on the transmission network and not the transmission network as a whole; and
- Are probable but too uncertain to include the proposed contingent project in the capital expenditure forecast.

### 8.4 Project requirement

EY and Powerlink have identified plausible developments in the Queensland region that would change not only the power transfer requirements between the Central West and Gladstone zones but also on the intra-connectors to northern and southern Queensland. Depending on the emergence of these developments, utilisation may increase to a point where it may become economically viable to upgrade its power transfer capacity to alleviate constraints. The transmission line augmentation between Calvale and Larcom Creek and between Larcom Creek and Calliope River is required to facilitate the efficient market operation.

Both the timing and magnitude of the expansion project and, therefore, the transmission requirements are uncertain at this time.

If the trigger event occurs the proposed contingent project would be reasonably required to meet the Rules capital expenditure objectives to efficiently meet expected demand for prescribed transmission services, comply with all applicable regulatory obligations associated with the provision of prescribed transmission services and maintain the quality, reliability and security of supply of prescribed services.

### 8.5 Contingent capital expenditure

The proposed contingent project is estimated to cost \$105.5m.

This estimate is based on the establishment of a double circuit 275kV transmission line between Calvale and Larcom Creek substations and rebuild of an existing single circuit 275kV transmission line between Larcom Creek and Calliope River as a double circuit 275kV transmission line.

By definition, it is not possible to accurately define the scope of proposed contingent projects at this early stage. Detailed planning analyses, project scopes and cost estimates will be required before any amendment to the revenue determination is considered by the AER should the specified trigger event for a proposed contingent project occur during the regulatory period.

The estimated net contingent capital expenditure exceeds the contingent project threshold of \$38.4m.

## 8.6 Demonstration of Rules compliance

Powerlink considers that the project should be accepted as a contingent project for the regulatory period as it is:

- a) Not otherwise provided for in the total forecast capital expenditure;
- b) Reasonably reflects the capital expenditure criteria, noting that the costs are an estimate at this point;
- c) Exceeds the contingent project threshold as set out in Section 8.5 above;
- d) Is reasonably required to achieve the capital expenditure objectives as set out in Section 8.4 above; and
- e) Has an appropriately defined trigger event as set out in Section 8.3 above.