

Network Capability Incentive Parameter Action Plan (NCIPAP)

Revised

November 2018

A decorative abstract graphic at the bottom of the page, consisting of overlapping, flowing, semi-transparent bands of color. The colors transition from purple and blue on the left to green, yellow, and red on the right, creating a sense of movement and depth.

Contents

1. Introduction	3
2. Overview of Network Capability Component.....	3
2.1. Period of the Action Plan	4
2.2. TasNetworks' existing NCIPAP program	4
3. Approach.....	5
3.1. Requirement of the scheme.....	5
3.2. Approach to identifying NCIPAP projects	5
3.3. Consultation with AEMO	6
3.4. Approach to Ranking Projects	7
4. Revised Action Plan.....	7
5. The Action Plan	10
5.1. Priority project 1 - Weather stations Burnie-Smithton 110 kV corridor.....	10
5.2. Priority Project 2 – Lightning withstand capability improvement on Norwood-Scottsdale-Derby 110 kV transmission corridor.....	13
5.3. Priority Project 3 - Port Latta double tee connection project	18
5.4. Priority Project 4 - Transmission line ground clearances improvement program ..	21

Disclaimer:

This record and accompanying annexures consist of confidential and commercially sensitive information prepared by the Asset Performance Team in Strategic Asset Management for the sole purpose of documenting the scope of the Network Capability Incentive Parameter Action Plan (NCIPAP). TasNetworks does not intend that this record be made public due to its confidential and sensitive contents, as to divulge such information may cause TasNetworks commercial disadvantage.

1. Introduction

The network capability component (NCC) is a component of the transmission Service Target Performance Incentive Scheme (STPIS) which was introduced by the Australian Energy Regulator (AER) in December 2012. This component has applied to TasNetworks from 1 July 2014.

This action plan has been revised in November 2018 after the AER published its draft decision for TasNetworks 2019-24 regulatory period. The revision is made in alignment with the AER's draft decision to rearrange ranking of approved/removed priority projects and to also include a new priority project identified in September 2018.

2. Overview of Network Capability Component (NCC)

The NCC is set out in Section 5 of the STPIS guideline¹ and facilitates improvements in the capability of transmission assets through operational expenditure and minor capital expenditure on a transmission network that results in:

- improved capability of those elements of the transmission system most important to determining spot prices; or
- improved capability of the transmission system at times when Transmission Network Users place greatest value on the reliability of the transmission system.

As a regulated network service provider, TasNetworks is required to comply with the AER's service target performance incentive scheme. As part of the TasNetworks upcoming revenue proposal, a network capability incentive parameter action plan (NCIPAP) must be submitted to the AER following endorsement by the Australian Energy Market Operator (AEMO). The network capability incentive parameter has been designed to benefit both consumers and market participants as described in the AER's final decision to introduce the component.

¹ Service Target Performance Incentive Scheme Version 5 (corrected), October 2015

2.1. Period of the Action Plan

TasNetworks intends to propose the identified NCIPAP priority projects as part of its revised revenue proposal from 2019-20 to 2023-24. It is envisaged that the period of the plan will be reviewed in conjunction with the determination on the regulatory control period.

2.2. TasNetworks' existing NCIPAP program

TasNetworks has implemented a number of low cost priority projects that were identified as part of the 2014-19 regulatory control period to improve network capability. Some of the completed projects are shown below in Table 1.

Table 1: NCIPAP projects completed between 2014-15 to 2016-17

Reason to undertake project	Completed project	Completion year
Better use of the available generation through a refinement of the Basslink export >300 MW fault level constraint	George Town Automatic Voltage Control Scheme (GTAVCS)	2014-15
Replacement of terminal equipment with limits below transmission line thermal limits to minimise thermal constraints	Replacement disconnectors on K and L bay on Sheffield-George Town 220 kV transmission Circuits	2015-16
Improve reliability and minimise return to service time through installation of motorised disconnector switch	Castle Forbes Bay Tee Switching Station disconnector upgrade	2015-16
Installation of dynamic ratings on supply transformers	Boyer Substation Knights Rd Substation	2015-16
Replacement of dead end assembly with limits below transmission line thermal rating	George Town-Comalco No 4 and 5 220 kV transmission circuit Liapootah-Waddamana No 1 220 kV transmission circuit	2015-16
Minimise return to service time through installation of fault location functionality on identified transmission circuits	Palmerston-Sheffield 220 kV transmission circuit	2015-16
Substandard spans verification and rectification	Waddamana-Liapootah No 1 220 kV Waddamana-Tungatinah No 1 and 2 110 kV Circuit Palmerston-Avooca 110 kV transmission circuit	2016-17

TasNetworks has also undertaken prudency checks prior to implementation of approved priority projects during the 2014-19 control period and revised its NCIPAP priority projects where there has been a change in circumstances and anticipated market benefits to spot market outcomes were no longer valid.

3. Approach

This section outlines the approach TasNetworks has used to identify and rank priority projects for the NCIPAP.

3.1. Requirement of the scheme

The AER's STPIS requires that a transmission network service provider (TNSP) must submit in its revenue proposal a NCIPAP:

- 1) identifying for every transmission circuit and injection point on its network, the basis and cause for the limit for each transmission circuit and injection point.
- 2) proposing the priority projects to be undertaken in the regulatory control period to improve the limit of the transmission circuits and injection points listed above through operational and/or minor capital expenditure projects. This proposal must include:
 - i. the total operational and capital cost of each priority project;
 - ii. the proposed value of the priority project improvement target in the limit for each priority project;
 - iii. the current value of the limit for the transmission circuits and/or injection points which the priority project improvement target is seeking to improve;
 - iv. the ranking of the priority projects in descending order based on the likely benefit of the priority project to customers or on wholesale market outcomes;
 - v. for each priority project, how the achievement of the priority project improvement target would result in a material benefit being achieved, including outline of key assumption on which this result is based; and
 - vi. in which the average total expenditure of the priority projects outlined in each regulatory year must not be greater than 1 per cent of the TNSP's average annual maximum allowed revenue proposed in its revenue proposal for the regulatory control period.

3.2. Approach to identifying NCIPAP projects

TasNetworks' have systematically reviewed its proposed priority projects on merit and undertaken market benefit assessment for inclusion of identified projects in the 2019-24 regulatory control period. In identifying NCIPAP projects, the reviews primarily considered the following:

- implement dynamic ratings on transmission circuit(s)² or circuits that still use AEMO work book ratings;
- lightning withstand capability improvement on selected transmission towers on Norwood-Scottsdale 110 kV transmission corridor to reduce the number of unplanned outages and re-classification period during lightning;
- transfer capability improvement to critical transmission substations and transmission lines that connect significant amounts of renewable wind generation; and
- improve transmission line to ground clearances to enable circuit operation to design temperature ratings.

3.3. Consultation with AEMO

The STPIS requires that:

The TNSP must consult with AEMO prior to submitting the NCIPAP about its review of its transmission circuits and injection point in its network and the potential priority projects which have been identified. This includes consultation with AEMO regarding:

- the potential for co-ordinated projects with other TNSPs;
- whether achieving the proposed priority project improvement targets will result in proposed priority project having a material benefit;
- the classification of priority projects based on their likely benefit to consumers or wholesale market outcomes; and
- the ranking of the priority projects.

TasNetworks completed a collaborative consultation with AEMO on proposed NCIPAP projects that was submitted to AEMO in July 2017. In addition to consultation completed in July 2017, TasNetworks also completed a recent consultation on an additional priority

² TasNetworks has already implemented dynamic rating on most of the transmission corridor.

project and received a revised project list after the AER published their draft decision in September 2018. The final outcome identified a total four priority projects that have met the STPIS requirement to facilitate improvement in the capability of transmission asset.

As stated in the explanatory statement regarding AEMO's consultative role in the development of the NCIPAP, AEMO also reviewed TasNetworks capital works program for 2019-24 regulatory control period. This is in line with the AER's STPIS guideline states that TNSPs must provide AEMO with a copy of their capital expenditure program for the upcoming regulatory control period when consulting on their NCIPAP³.

3.4. Approach to Ranking Projects

TasNetworks has completed its consultation with AEMO and received feedback and comments to support the market benefit outcomes for each identified priority project. Accordingly, the ranking of the final priority projects have been amended on the basis of a mutually agreed methodology for market benefit calculation.

The STPIS requires proposed projects to be ranked in descending order based on the likely benefit of the project to consumers and wholesale market outcomes (i.e. payback period⁴). Table 2 summarises the ranking of TasNetworks' proposed NCIPAP for the 2019-24 regulatory control period after consultation with AEMO completed in early November 2018.

4. Revised Action Plan

The original action plan (detailed in Appendix A) submitted to the AER in January 2018 has been revised after the AER published its draft decision in September 2018. In its draft decision, the AER removed priority projects 1 and 4 from the original action plan, considering these are reliability improvement projects and did not meet the STPIS requirement to facilitate improvements in the capability of transmission assets. TasNetworks accepted the AER draft decision and agreed to remove project 1 and 4 in the revised proposal.

In September 2018, TasNetworks identified an additional project that has met the STPIS requirement to facilitate connection of renewable generation at Port Latta Substation and

³ The AER Final Decision, Electricity transmission network service providers, Service Target Performance Incentive Scheme, December 2012, page 26

⁴ Payback period in years are calculated dividing total project cost by annual market benefit.

will improve transfer capability of existing transmission network with small-scale investment. TasNetworks has completed necessary consultation, a prudency check on its market benefit calculation from AEMO and acquired endorsement in early November 2018.

In the meantime, TasNetworks identified an additional NCIPAP project that meets the STPIS requirement to facilitate improvement in transfer capability of transmission network at Port Latta 110 kV Substation. TasNetworks received prudency check, feedback and endorsement.

The revised summary sheet that outlines final list of priority project and its ranking based on payback period are detailed in Table 2.

Table 2 Revised Network Capability Incentive Parameter Action Plan 2019-24

TasNetworks Project Ranking	Project Name	Scope of Works	Payback period in years	Annual Market Benefits (\$)	Project Cost Level 1 estimate ⁵			Project Drivers and Material benefit	Benefit Category
					Capex	Opex	Total Project Cost		
1	Weather Station for Burnie-Smithton 110 kV transmission corridor	Install a new weather station near Smithton to enable dynamic rating of Burnie Smithton 110 kV transmission line	3.0	\$124,415	\$364,927	\$1,825	\$366,751	Enable dynamic rating of the Burnie-Smithton transmission circuit by changing current AEMO workbook rating to thermal rating calculator (TRcalc) program TasNetworks and AEMO agreed that a 30 MW of additional new generation could be dispatched once the dynamic rating is applied to the Burnie-Smithton 110 kV transmission circuit.	Improves transfer capability
2	Lightning withstand capability improvement on Norwood-Derby-Scottsdale 110 kV transmission corridor	Improve footing earthing at selected towers on the Norwood Scottsdale Derby transmission circuits.	4.2	\$187,547	\$800,000	-	\$800,000	Reduce the unplanned outages and re-classification of transmission circuit due to lightning strikes. TasNetworks market benefits calculation is based on increased energy output from Musselroe windfarm. Reliability benefit at Derby and Scottsdale consumers was not included in the benefit calculation.	Improves transfer capability
3	Port Latta 110 kV double tee connection	(1) Rearrange the 110 kV network connection at Port Latta Substation to double tee from Burnie-Smithton circuits instead of existing loop in and loop out arrangement from one of these circuits. (2) Revise the protection and communication according to the proposed network arrangement.	17.16	\$51,696	\$845,000	\$42,250	\$845,000	Proposed project improvement target will result in the proposed priority project having a material benefit if additional new generation were to be built in Port Latta/Smithton area Material benefit can be realised with increased connection of new generation in Port Latta/Smithton area. TasNetworks has received a number of connection applications for wind farm development in Port Latta and/or Smithton area to connect on the Burnie-Smithton 110 kV circuits, targeting prior to or at the beginning of the 2019-24 regulatory control period. The Burnie-Smithton 110 kV transmission circuits currently operated with AEMO work book rating. TasNetworks made a NCIPAP proposal "Install a new weather station near Smithton to enable dynamic rating" in its 2019-24 revenue proposal. This has been accepted by AER's draft decision in September 2018. The proposed works to rearrange 110 kV network at Port Latta would allow increased transfer capability enabling the transmission line to operate at dynamic line ratings.	Improves transfer capability
4	Transmission line ground clearances improvement program	Improve ground clearances at identified sites on the 110 kV and 220 kV transmission lines by ground profiling, conductor tensioning, waist extension and raising tower heights. Transmission lines are listed in the project description details on page 23.	20.4	\$147,200	\$3,000,000	-	\$3,000,000	This project addresses potential de-rating of existing transmission capacity and dispatch constraints to selected Hydro's generation due to insufficient ground clearances identified during recent LiDAR survey. In addition, this project also reduces the safety and environmental risks presented by insufficient ground clearances and provide increased transfer levels to hydro generation. Market benefits include only reduced cost of generation rescheduling and do not include value of unserved energy.	Improves safety, reliability of supply and transfer capability.
Total Project Cost					\$5,009,927	\$44,074	\$5,054,001		

⁵ ±30 per cent accuracy allowance

5. The Action Plan

As part of the revenue proposal for 2019-24 regulatory control period, TasNetworks is required to comply with the Australian Energy Regulator's STPIS. TasNetworks has identified four priority projects with a total project cost⁶ of \$5.05 million. The proposed NCIPAP has been developed in accordance with the requirement of the STPIS guidelines.

5.1. Priority project 1 - Weather stations Burnie-Smithton 110 kV corridor

Reason to undertake the project:

Bluff Point and Studland Bay wind farms connect to the network at Smithton Substation. Australian Energy Market Operator (AEMO) workbook ratings are applied to the Burnie-Smithton 110 kV transmission line to allow increased generation export above non-firm static line ratings. Figure 1 illustrates the 110 kV transmission network from Smithton Substation to the Bluff Point and Studland Bay wind farms.

There is strong interest for additional wind generation in the North-West coast of Tasmania. TasNetworks has recently received a number of connection applications for wind farm development in this area with connection targeting prior to or at the beginning of the 2019-24 regulatory control period. The Burnie-Smithton 110 kV transmission circuit currently operated with AEMO work book rating.

The installation of a weather station in close proximity of the Burnie-Smithton 110 kV transmission corridor will allow this transmission circuit to operate at dynamic ratings, allowing further increase in transfer capability. The proposed investment eventually allow low cost new wind generation to be dispatched in the National Electricity Market which would otherwise be constrained with current AEMO work book ratings. AEMO in its review also agreed that the proposed investment will allow a further increase in 20 MW–30 MW transfer capability with base case scenario using 30 MW transfer capability improvement for market benefit calculation.

⁶ The project cost is based on level 1 with \pm 30 per cent accuracy allowance. This cost does not include contingency and cost allocation methodology.

Figure 1: 110 kV transmission network from Smithton to the Bluff point and Studland Bay wind farms



Assumptions:

Burnie weather station does not capture sufficient data in order to identify the dynamic rating of a section of the Burnie-Smithton transmission line. The dynamic rating of the transmission line can be calculated from the data captured from the proposed weather station near Smithton and the existing Burnie weather station.

The project is justified on the basis of low cost future wind generation displacing the higher cost generation in Victoria. If the dynamic rating is not in operation, the wind generation would be constrained and that would be a loss of generation. The Victorian pool price is used as it represents the marginal generator in Victoria. Therefore the Victorian pool price represents full benefit to new wind generation. This is assuming a competitive market where price equals cost.

For the purpose of assessment of market benefit and payback period, TasNetworks and AEMO agreed that 30 MW of additional new generation can be dispatched once the dynamic rating is applied to the Burnie-Smithton 110 kV transmission corridor. This equates to \$124, 415 annual market benefit with a payback period of 3.0 years.

Project description:

Transmission Circuit / Injection Point	Burnie-Smithton 110 kV transmission line
Project	Weather stations Burnie-Smithton 110 kV corridor
Scope of works	Install a new weather station near Smithton to enable dynamic rating of Burnie-Smithton 110 kV transmission line
Current value of the limit	AEMO work book ratings of Burnie-Smithton 110 kV transmission line
Target limit	Dynamic rating of Burnie-Smithton 110 kV transmission line, resulting in an expected average 30 MW increase.
Priority project improvement target	Increased thermal rating of Burnie-Smithton 110 kV transmission line
Completion date	June 2022
Capital cost	\$364,927
Operational cost	A 0.5 per cent operation and maintenance cost of Capex
Annual Market benefit	\$ 124, 415
Payback Period	3.0 years

5.2. Priority Project 2 – Lightning withstand capability improvement on Norwood-Scottsdale-Derby 110 kV transmission corridor

Background

The Norwood-Scottsdale 110 kV transmission circuits provide a radial connection to Scottsdale and Derby substations and a generator connection for Musselroe Wind Farm at Derby Substation. The transmission circuits from Norwood Substation comprise of:

- A three ended Norwood-Scottsdale-Derby circuit (NW-SD-DE); and
- A two ended Norwood-Scottsdale circuit (NW-SD).

Both circuits are installed on double circuit towers to Scottsdale substation and single circuit towers to Derby substation. Musselroe Wind Farm (168 MW) radially connects to Derby Substation. The geographical and single line connection to Scottsdale, Derby substations and Musselroe windfarm is shown in Figures 2 and 3 below:

Figure 2 Norwood – Scottsdale-Derby- Musselroe 110 kV connection

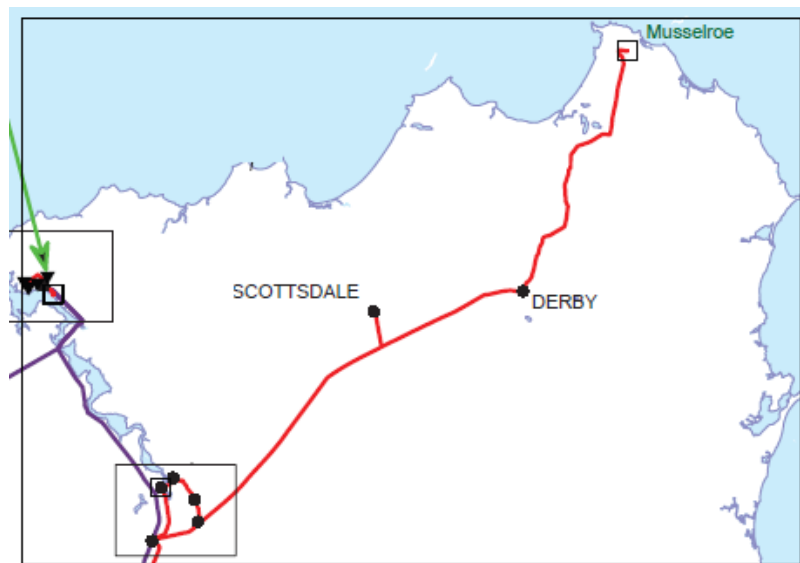
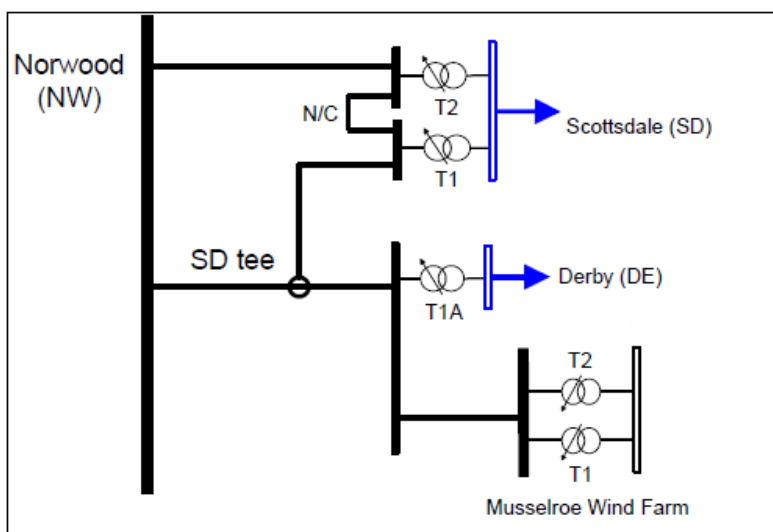

Figure 3 Norwood – Scottsdale-Derby- Musselroe 110 kV connection single line diagram**Reason to undertake project:**

The 110 kV double circuit section between Norwood and Scottsdale has been identified as frequently being re-classified as a credible contingency due to lightning forecast detected in close proximity of the transmission corridor. The double circuit NW-SD and the NW-SD-DE 110 kV transmission circuits have tripped several times with loss of Musselroe generation during the re-classification period. It is considered that the lightning performance of the NW-SD-DE transmission corridor is sub-optimal and there are towers on the NW-SD and NW-SD-DE with very high footing impedances in exposed areas of high altitude that present a significant back flashover risk during a lightning strike, with resultant tripping of contingent low cost wind generation.

The historical record of transmission line re-classification data in Appendix B, C and D shows that from January 2013, the NW-SD-DE transmission corridor was re-classified 82 times, with an average reclassification period of two hours⁷. On average, this transmission corridor is reclassified twice a month and trips on a frequent basis during re-classification periods. In the last eight months, the NW-SD-DE transmission circuit tripped seven times due to lightning strikes where Musselroe generation was lost three times (average generation loss of 74 MW).

Figures 4 and 5 shows the interrelation of footing impedance of the NW-SD and SD-DE section of the NW-SD-DE 110 kV transmission corridor with respect to altitude. Figure 6

⁷ Average reclassification period was 1 hour 53 minutes

primarily depicts section of NW-SD (towers 113-129) having relatively high footing impedance in exposed areas where a lightning strike would result in back flashover. It is TasNetworks view that improving the footing resistance of exposed towers will significantly reduce the risk of outages due to lightning and that the NW-SD-DE 110 kV transmission circuit should be taken out from the re-classification list post implementation and improve transmission availability that connects low cost wind generator in the NEM.

Figure 4 Norwood-Scottsdale Footing Impedance (TL479)

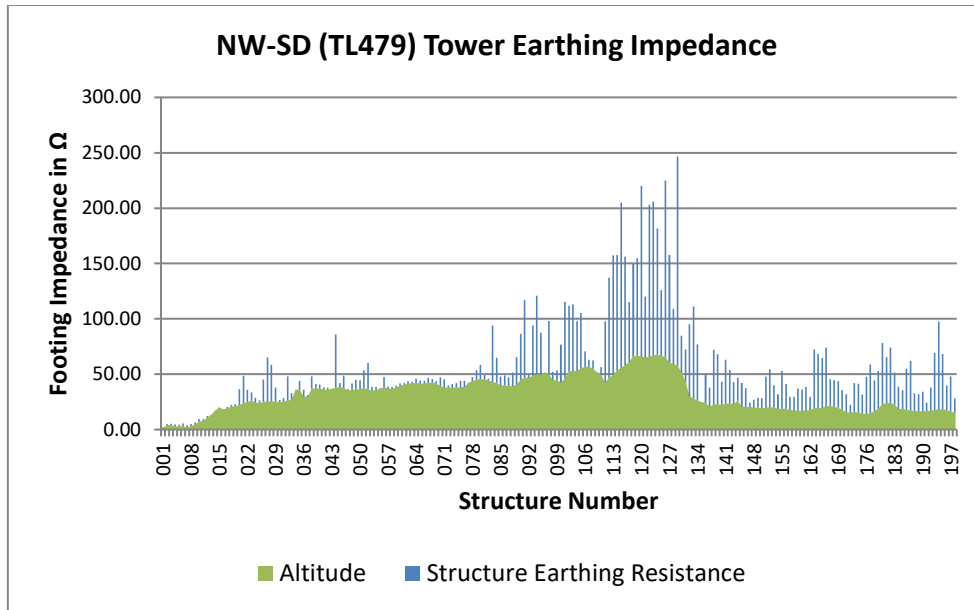
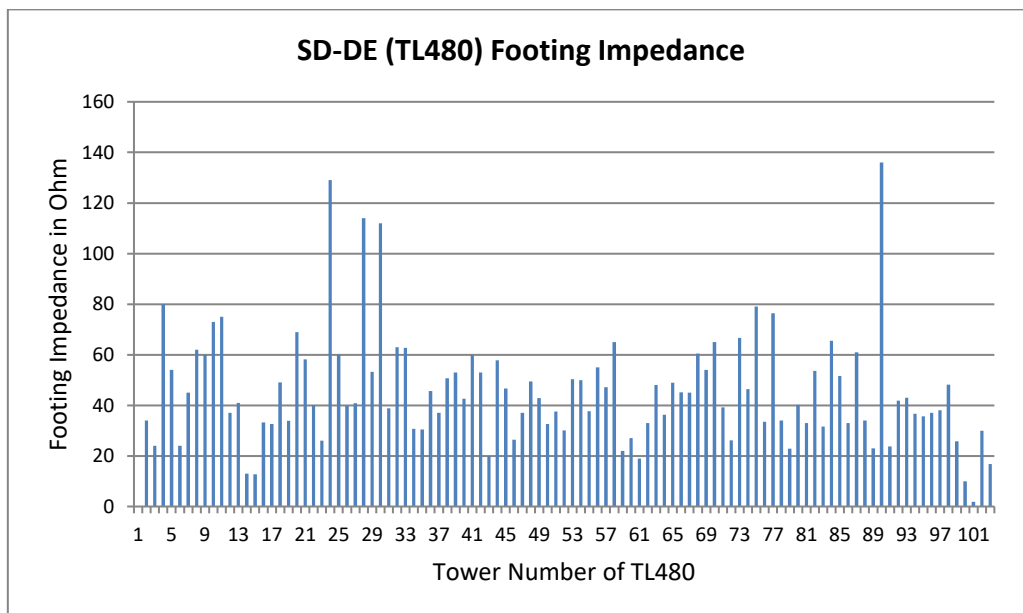

Figure 5 Scottsdale-Derby Footing Impedance (TL480)



Market Benefit Analysis

Reclassification of double circuit transmission circuits as a credible event is considered “Reasonably Possible” under the NER Rules (4.2.3, b) and AEMO must take all reasonable steps to manage these events proactively (4.2.3A b). During re-classification, the AEMO manages sufficient spinning reserve to cater for loss of credible generators in the NEM.

The market benefit analysis assumes that the cost to manage a re-classification event for the loss of the NW-SD-DE 110 kV transmission corridor requires AEMO to displace Musselroe wind generation by re-scheduling a mainland generator, predominantly from Victoria. Because Musselroe wind farm bids at a zero or negative price, the marginal price to manage the loss of a wind generator in this case would be the Victorian pool price (i.e. \$59.33/MWh⁸). As discussed above, the NW-SD-DE 110 kV transmission corridor is on average re-classified twice a month for approximately two hours. It is estimated the project requires earthing improvement works at 20 exposed towers with unacceptable high footing impedance at an average cost of \$40,000 per tower.

An improved footing impedance in the range of 5-10 Ω will enable this transmission corridor to withstand up to 25 kA magnitude lightning strikes (refer to Appendix D, tables 2 and 3) enabling the corridor to cater for 98 per cent of the lightning strikes. Appendix E shows the concentration of negative and positive lightning strikes in a 10 km proximity of the NW-SD-DE 110 kV transmission corridor, with the dot size representing magnitude of the strikes.

The annual market benefit is calculated with a 40 per cent capacity factor for Musselroe wind farm (168 MW) for duration of 48 hours and a generation re-scheduling cost of the Victorian pool price. The calculation equates to \$275,000 annual market benefit with a payback period of 4.2 years.

⁸ AEMO applied a weighted average price of \$59.33/MWh for Victorian brown coal and gas generation in 2016-17 financial year compared to TasNetworks initially proposed Victorian pool price of \$86.15/MWh.

Project description:

Transmission Circuit / Injection Point	Norwood-Scottsdale-Derby 110 kV transmission circuit
Project	Lightning withstand capability improvement on Norwood-Scottsdale-Derby 110 kV transmission corridor
Scope of works	Improve footing earthing at selected towers on the Norwood-Scottsdale-Derby transmission circuits identified as having sub-optimal lightning outage performance
Current value of the limit	Sub-optimal transmission line lightning performance at an average 4.5 outages per year due to lightning strikes, with an average re-classification twice a month for an average of two hours.
Target limit	Removal of Norwood-Scottsdale 110 kV double transmission circuits from re-classification list.
Priority project improvement target	Reduce the unplanned outage frequency and re-classification of transmission circuit due to lightning per year.
Completion date	June 2020
Capital cost	\$800,000
Operational cost	\$0
Annual Market benefit	\$187,547 $[(168*0.4)*2*2*12 \text{ hours}*\$59.33/\text{MWh}]*0.98]$
Payback Period	4.2 years

5.3. Priority Project 3 - Port Latta double tee connection project

Reason to undertake the project:

Bluff Point and Studland Bay wind farms connect to the 110 kV network at Smithton Substation. AEMO workbook ratings are applied to the Burnie–Smithton 110 kV transmission line to allow increased generation export above non-firm static line ratings. Figure 6 illustrates the 110 kV transmission network from Burnie to the Bluff Point and Studland Bay wind farms via Smithton Substation.

Figure 6 110 kV transmission network from Burnie to the Bluff point and Studland Bay wind farms



There is strong interest for additional wind generation in the North west coast of Tasmania. TasNetworks has recently received a number of connection applications for wind farm development in this area. The new wind farm connection is expected to be connected on the Burnie–Smithton 110 kV transmission circuit prior to or at the beginning of the 2019-24 regulatory control period. The Burnie–Smithton 110 kV transmission circuits currently operated with AEMO workbook rating. As the first step, dynamic ratings of the Burnie–Smithton 110 kV transmission line, through the installation of a weather station, will allow for further increase in line rating, allowing reduced constraint of new wind generation that would occur if the transmission line work book ratings were utilised.

Establishing a *double tee* connection to Port Latta Substation will reduce constraint of new wind generation through balancing the power flow in both circuits and utilising the extra capacity available in between Burnie and Port Latta 110 kV section. The existing and the proposed network connections of Port Latta Substation are shown in Figure 7.

Furthermore, establishing a *double tee* connection to Port Latta Substation improves the voltage instability issues in the Burnie-Smithton corridor after the connection of new wind farms to Port Latta Substation.

Figure 7 Port Latta Substation 110 kV connection

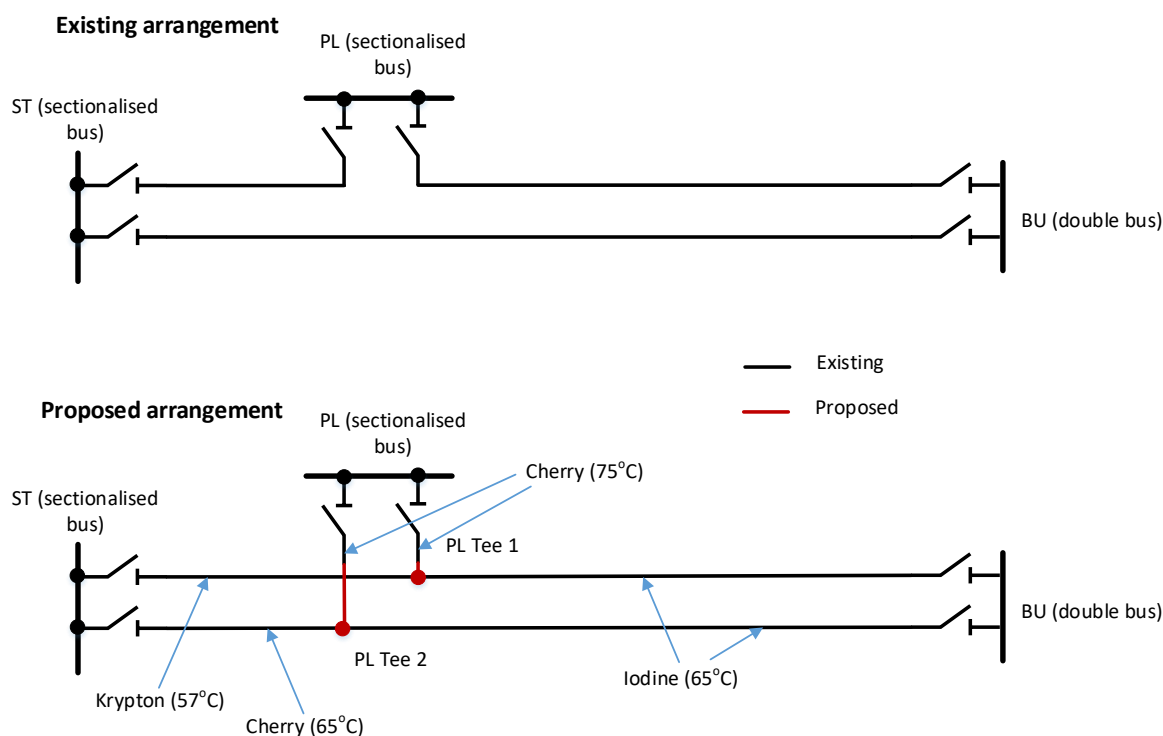

Assumptions:

The project is justified on the basis of low cost future wind generation displacing the higher cost generation in Victoria. If the proposed project is not established, the wind generation would be constrained and that would be a loss of generation. The Victorian pool price is used for market benefit calculation as it represents the marginal generator in Victoria. Therefore the Victorian pool price represents the full benefit to new wind generator. This aligns with the market modelling process proposed in Regulatory investment test for transmission application guideline of Australian Energy Regulator.

The capacity benefit is identified based on the static summer rating gain. This is a minimum capacity gain and actual benefit would be much higher under dynamic line rating. The extra benefit due to improvements in network stability after the proposed wind connections in Port Latta was identified. The proposed *double tee* arrangement helps to reduce the dynamic reactive power requirement from 20 MVAR to 8 MVAR.

Project description:

Transmission Circuit / Injection Point	Burnie-Smithton 110 kV transmission line
Project	Port Latta 110kV double tee connection
Scope of works	Establish a double tee connection to Port Latta Substation from Burnie-Smithton 110 kV double circuit transmission line instead of the existing loop in and loop out connection from one of the circuits
Current value of the limit	AEMO work book ratings of Burnie-Smithton 110 kV transmission line. This is to be upgraded to dynamic rating providing at least 30 MW capacity increase.
Target limit	An expected 15 MW capacity increase on top of dynamic rating of Burnie-Smithton 110 kV transmission line expected with the installation of the proposed weather station.
Priority project improvement target	Increased thermal rating of Burnie-Smithton 110 kV transmission line
Completion date	June 2023
Capital cost	\$845,000
Operational cost	A 0.5 per cent operation and maintenance cost of Capex
Annual Market benefit	\$ 49,316 (excluding the benefits of offset dynamic reactive support requirement. The will reach to \$171,852 with the consideration of offset dynamic reactive support).
Payback Period	17.0 years (5 years with the consideration of offset dynamic reactive support)

5.4. Priority Project 4 - Transmission line ground clearances improvement program

Reason to undertake the project:

A preliminary result of recent Light Detection And Ranging (LiDAR) survey undertaken by TasNetworks identified that a number of 110 kV and 220 kV transmission lines require ground clearance improvements to ensure optimum operation of these transmission circuits to their design temperature. If not addressed, these identified transmission sections will constrain the flow, especially during high summer months, reducing its capacity and presenting potential safety and environmental risks.

Primary drivers to undertake this project are:

- to increase transmission capacity by improving ground clearances;
- to re-establish transmission circuit operability to its design temperature;
- to reduce TasNetworks safety and environmental risks including bush fire; and
- to meet transmission circuit clearance compliance.

Assumptions

A major design consideration of transmission lines is the ground clearance of conductors at the required maximum operating temperature. To comply with standards the minimum conductor to ground clearance at design temperature must be greater than 6.7 metres for 110 kV transmission lines, and greater than 7.5 metres for 220 kV transmission lines.

The required clearances are defined in 'AS/NZS 7000:2010 Overhead line design—Detailed procedures' and are designed to protect the general public, landowners, TasNetworks employees and contractors from the hazards of high voltage transmission lines, whether on foot or in a vehicle.

In the worst case with critical radial transmission circuits and high ambient temperature periods, the allowable power flow could be reduced to zero due to identified substandard ground clearances. Extended outages of this radial transmission circuit during high summer months will severely constrain supply to parts of the network.

While undertaking market benefit calculation, it is assumed that the substandard ground clearances will constrain dispatch of radial generation above 25°C. Assumed weather condition to generate a new line rating using transmission rating calculator (TRCALC) program is depicted below in figure 8.

Figure 8: Transmission rating calculator program

```

Ambient Temperature : 25
Wind Speed : 0.5
Wind Angle : 15
Direct Solar Radiation : 960
Diffuse Solar Radiation : 110
    
```

The actual binding⁹ hours above 25°C was calculated using historical flow and corresponding temperature for dispatch intervals using 2016-17 data. A generation rescheduling price of \$30/MWh¹⁰ between Tasmania and Victoria is considered as a base case scenario to calculate the potential market benefit per year.

The payback period of the project is calculated using total project cost divided by the potential market benefit per year. A new TRCALC rating using ambient conditions presented above for a transmission circuit¹¹ that connects a generator in the west coast area of Tasmania is presented below in figure 9.

Figure 9: TRCALC plot for TERN conductor using assumed weather condition

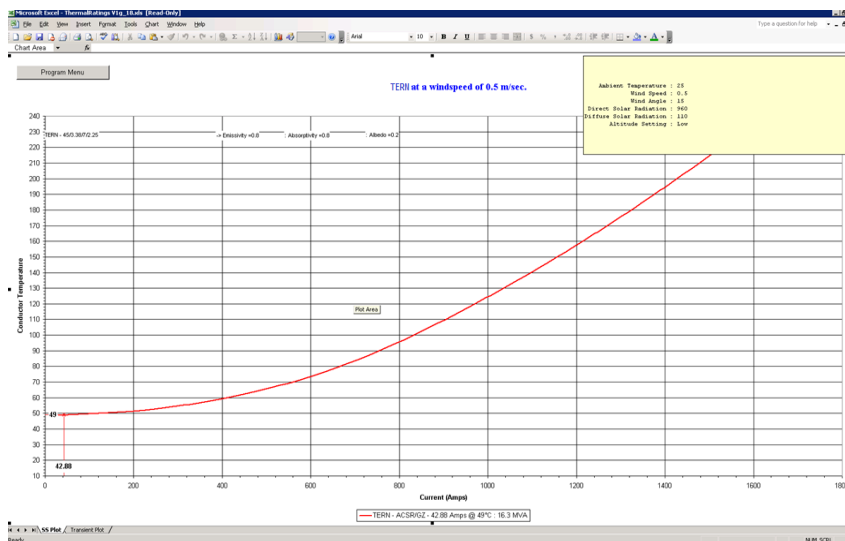

⁹ Justification_sub_clearance.xlsx

¹⁰ As de-rating of transmission circuits that connect predominantly hydro generations are considered to be re-dispatched at different interval. The cost for Hydro generation re-dispatch from Victoria to Tasmania is considered to be \$30/MWh.

¹¹ Transmission circuit identifier is masked due to confidential information

Project description:

Transmission Circuit / Injection Point	Transmission line ground clearance improvement program
Project	Transmission line ground clearance improvement for 110 kV and 220 kV transmission circuits
Scope of works	<p>Improve ground clearances at identified sites on the 110 kV and 220 kV transmission lines by ground profiling, conductor tensioning, waist extension and raising tower heights on the following transmission lines:</p> <ul style="list-style-type: none"> • Sheffield-Fisher 220 kV transmission line (TL512); • Farrell -Mackintosh 110 kV transmission line (TL453); • Sheffield-Davis Gate transmission line (TL450); • Tungatinah-Butters Gorge 110 kV transmission lines (TL 407 and TL408); • Burnie-Smithton 110kV transmission line (TL415); • Farrell-Que-Waratah Tee 110 kV transmission line(TL452); • Sheffield-Railton 110 kV transmission line (TL416); • New Norfolk-Creek Rd 110 kV transmission line (TL463); and • George Town-Starwood 110 kV transmission line (TL470).
Current value of the limit	Existing transmission line design temperature
Target limit	Restore transmission circuit operateability to its design temperature ratings
Priority project improvement target	Improvement of line to ground clearance. Reinstatement of design temperature ratings and increase ratings where possible.
Completion date	December 2022
Capital cost	\$3,000,000
Operational cost/year	\$0
Market benefit/year	The estimated market benefit ¹² of this project \$147,200 per year
Payback period	20.4 years

¹² For the purpose of market benefit calculation, the amount of unserved energy to customers' load is not considered.

Appendix A: Original NCIPAP Action Plan submitted to the AER in January 2018.

TasNetworks Project Ranking	Project Name	Scope of Works	Payback period in years	Annual Market Benefits (\$)	Project Cost Level 1 estimate ¹³	Project Drivers and Material benefit
1	Waratah Tee Switching Station disconnector motorisation	(1) Replace manually operated disconnectors A129, B129 and C129 at Waratah Tee Switching Station with remotely operated, motorised disconnectors. (2) Provision of AC/DC supplies and telecommunications to Waratah Tee Switching Station.	1.2	\$518,430.00	\$610,000	Minimise supply restoration time at Savage River Substation from an average of 228 min to approximately within 10 min, for sustained faults on the Farrell-Que-Savage River or Burnie-Hampshire-Savage River 110 kV transmission circuit. Market benefits based on reduction in expected unserved energy (USE) due to reduced restoration time after an outage.
2	Weather Station for Burnie-Smithton 110 kV transmission corridor	Install a new weather station near Smithton to enable dynamic rating of Burnie Smithton 110 kV transmission line	3.0	\$124,415	\$364,927	Enable dynamic rating of the Burnie-Smithton transmission circuit by changing current AEMO workbook rating to thermal rating calculator (TRcalc) program TasNetworks and AEMO agreed that a 30 MW of additional new generation could be dispatched once the dynamic rating is applied to the Burnie-Smithton 110 kV transmission circuit.
3	Lightning withstand capability improvement on Norwood-Derby-Scottsdale 110 kV transmission corridor	Improve footing earthing at selected towers on the Norwood-Scottsdale Derby transmission circuits.	4.2	\$187,547	\$800,000	Reduce the unplanned outages and re-classification of transmission circuit due to lightning strikes. TasNetworks market benefits calculation is based on increased energy output from Musselroe windfarm. Reliability benefit at Derby and Scottsdale consumers was not included in the benefit calculation.
4	Farrell Substation 220 kV second bus coupler installation	Install a second 220 kV bus coupler in series with the existing bus coupler A752B and modify protection and control schemes as required at Farrell 220 kV Substation.	13.5	\$91,500	\$1,237,914	Proposed second series bus coupler circuit breaker is to reduce the risk of total loss of supply to Roseberry, Newton, Queenstown, Que and Savage River substations and loss of generation connected to Farrell substation and potential loss of partial or full system blackout due to load and generation imbalance. Market benefits based on reduction in expected unserved energy (USE) due to reduced restoration time after an outage.
5	Transmission line ground clearances improvement program	Improve ground clearances at identified sites on the 110 kV and 220 kV transmission lines by ground profiling, conductor tensioning, waist extension and raising tower heights. Transmission lines are listed in the project description details on page 23.	20.4	\$147,200	\$3,000,000	This project addresses potential de-rating of existing transmission capacity and dispatch constraints to selected Hydro's generation due to insufficient ground clearances identified during recent LiDAR survey. In addition, this project also reduces the safety and environmental risks presented by insufficient ground clearances and provide increased transfer levels to hydro generation. Market benefits include only reduced cost of generation rescheduling and do not include value of unserved energy.

Appendix B: Historical record of the NW-SD-DE 110 kV transmission re-classification

Corridor	Type	From Time	To Time	Duration (hh:mm:ss)	Comments
NW-SD and NW-SD-DE 110kV	Reclass	03/09/17 23:55	04/09/17 00:50	0:55:00	lightning
NW-SD and NW-SD-DE 110kV	Reclass	17/08/17 04:10	17/08/17 05:40	1:30:00	Lightning
NW-SD and NW-SD-DE 110kV	Reclass	16/08/17 03:28	16/08/17 04:30	1:02:00	lightning
NW-SD and NW-SD-DE 110kV	Reclass	16/08/17 03:28	16/08/17 04:30	1:02:00	
NW-SD and NW-SD-DE 110kV	Reclass	11/08/17 21:30	12/08/17 00:45	3:15:00	Lightning
NW-SD and NW-SD-DE 110kV	Reclass	26/07/17 01:15	26/07/17 03:30	2:15:00	lightning
NW-SD and NW-SD-DE 110kV	Reclass	25/07/17 21:50	25/07/17 23:50	2:00:00	lightning
NW-SD and NW-SD-DE 110kV	Reclass	23/07/17 07:05	23/07/17 07:55	0:50:00	Lightning
NW-SD and NW-SD-DE 110kV	Reclass	27/05/17 23:30	28/05/17 04:15	4:45:00	lightning
NW-SD and NW-SD-DE 110kV	Reclass	06/05/17 15:16	06/05/17 17:03	1:47:00	lightning
NW-SD and NW-SD-DE 110kV	Reclass	16/03/17 10:20	16/03/17 11:30	1:10:00	Lightning
NW-SD and NW-SD-DE 110kV	Reclass	02/03/17 19:10	02/03/17 21:10	2:00:00	lighting
NW-SD and NW-SD-DE 110kV	Reclass	30/12/16 01:11	30/12/16 05:30	4:19:00	Lightning
NW-SD and NW-SD-DE 110kV	Reclass	05/12/16 01:45	05/12/16 04:25	2:40:00	Lightning in Area
NW-SD and NW-SD-DE 110kV	Reclass	21/11/16 23:35	22/11/16 00:25	0:50:00	Lightning
NW-SD and NW-SD-DE 110kV	Reclass	21/11/16 19:40	21/11/16 21:35	1:55:00	Lightning
NW-SD and NW-SD-DE 110kV	Reclass	21/11/16 03:05	21/11/16 05:25	2:20:00	Lightning
NW-SD and NW-SD-DE 110kV	Reclass	30/10/16 08:35	30/10/16 09:55	1:20:00	Lightning in area
NW-SD and NW-SD-DE 110kV	Reclass	18/10/16 16:00	18/10/16 18:55	2:55:00	Lightning
NW-SD and NW-SD-DE 110kV	Reclass	14/08/16 02:40	14/08/16 03:20	0:40:00	Lightning
NW-SD and NW-SD-DE 110kV	Reclass	22/07/16 02:10	22/07/16 05:10	3:00:00	lightning
NW-SD and NW-SD-DE 110kV	Reclass	12/07/16 17:30	12/07/16 18:10	0:40:00	Lightning in the area
NW-SD and NW-SD-DE 110kV	Reclass	16/05/16 23:35	17/05/16 05:35	6:00:00	Lightning
NW-SD and NW-SD-DE 110kV	Reclass	16/05/16 23:35	16/05/16 23:35	0:00:00	Lightning
NW-SD and NW-SD-DE 110kV	Reclass	16/05/16 19:55	16/05/16 21:50	1:55:00	Lightning
NW-SD and NW-SD-DE 110kV	Reclass	01/05/16 10:25	01/05/16 11:40	1:15:00	Lightning
NW-SD and NW-SD-DE 110kV	Reclass	01/05/16 10:25	01/05/16 11:39	1:14:00	Lightning
NW-SD and NW-SD-DE 110kV	Reclass	01/05/16 06:41	01/05/16 08:50	2:09:00	Lightning
NW-SD and NW-SD-DE 110kV	Reclass	09/03/16 00:50	09/03/16 03:05	2:15:00	Lightning
NW-SD and NW-SD-DE 110kV	Reclass	29/01/16 07:35	29/01/16 19:30	11:55:00	Lightning
NW-SD and NW-SD-DE 110kV	Reclass	29/01/16 00:55	29/01/16 07:35	6:40:00	Lightning
NW-SD and NW-SD-DE 110kV	Reclass	28/01/16 11:50	28/01/16 20:30	8:40:00	Lightning
NW-SD and NW-SD-DE 110kV	Reclass	21/01/16 11:45	21/01/16 12:35	0:50:00	fire
NW-SD and NW-SD-DE 110kV	Reclass	13/01/16 23:15	13/01/16 23:50	0:35:00	Lightning in the area
NW-SD and NW-SD-DE 110kV	Reclass	13/01/16 20:46	13/01/16 22:00	1:14:00	Lightning in the area
NW-SD and NW-SD-DE 110kV	Reclass	15/12/15 16:15	15/12/15 17:55	1:40:00	Lightning
NW-SD and NW-SD-DE 110kV	Reclass	30/11/15 22:35	30/11/15 23:30	0:55:00	Lightning
NW-SD and NW-SD-DE 110kV	Reclass	25/11/15 23:05	25/11/15 23:40	0:35:00	Lightning
NW-SD and NW-SD-DE 110kV	Reclass	06/11/15 21:15	06/11/15 22:35	1:20:00	lightning
NW-SD and NW-SD-DE 110kV	Reclass	06/11/15 19:40	06/11/15 20:30	0:50:00	lightning
NW-SD and NW-SD-DE 110kV	Reclass	06/11/15 14:40	06/11/15 16:25	1:45:00	lightning
NW-SD and NW-SD-DE 110kV	Reclass	25/10/15 23:20	26/10/15 00:55	1:35:00	lightning
NW-SD and NW-SD-DE 110kV	Reclass	16/10/15 09:40	16/10/15 10:10	0:30:00	Lightning in area
NW-SD and NW-SD-DE 110kV	Reclass	29/09/15 04:10	29/09/15 05:10	1:00:00	
NW-SD and NW-SD-DE 110kV	Reclass	29/09/15 00:10	29/09/15 03:25	3:15:00	
NW-SD and NW-SD-DE 110kV	SPS Firm	15/09/15 02:40	15/09/15 03:40	1:00:00	Lightning In Area
NW-SD and NW-SD-DE 110kV	Reclass	14/09/15 21:15	14/09/15 22:00	0:45:00	Lightning In Area
NW-SD and NW-SD-DE 110kV	Reclass	02/08/15 14:15	02/08/15 15:15	1:00:00	Lightning in area
NW-SD and NW-SD-DE 110kV	Reclass	24/07/15 20:20	24/07/15 21:50	1:30:00	lightning
NW-SD and NW-SD-DE 110kV	Reclass	22/07/15 07:13	22/07/15 08:22	1:09:00	lightning
NW-SD and NW-SD-DE 110kV	Reclass	22/07/15 07:13	22/07/15 08:22	1:09:00	
NW-SD and NW-SD-DE 110kV	Reclass	28/05/15 17:20	28/05/15 19:05	1:45:00	Lightning In Area
NW-SD and NW-SD-DE 110kV	Reclass	28/05/15 11:15	28/05/15 12:05	0:50:00	Lightning In Area
NW-SD and NW-SD-DE 110kV	Reclass	26/03/15 03:50	26/03/15 05:45	1:55:00	lightning

NW-SD and NW-SD-DE 110kV	Reclass	28/02/15 21:15	28/02/15 23:00	1:45:00	Lightning
NW-SD and NW-SD-DE 110kV	Reclass	23/01/15 01:50	23/01/15 04:00	2:10:00	lightning
NW-SD and NW-SD-DE 110kV	Reclass	08/01/15 12:25	08/01/15 14:05	1:40:00	Lightning
NW-SD and NW-SD-DE 110kV	Reclass	04/01/15 00:50	04/01/15 01:40	0:50:00	lightning
NW-SD and NW-SD-DE 110kV	Reclass	16/12/14 02:25	16/12/14 03:10	0:45:00	Lightning
NW-SD and NW-SD-DE 110kV	Reclass	10/12/14 18:30	10/12/14 22:25	3:55:00	lightning
NW-SD and NW-SD-DE 110kV	Reclass	01/12/14 08:30	01/12/14 09:20	0:50:00	lightning in the area
NW-SD and NW-SD-DE 110kV	Reclass	01/12/14 08:30	01/12/14 08:50	0:20:00	lightning in the area
NW-SD and NW-SD-DE 110kV	Reclass	01/12/14 05:07	01/12/14 07:40	2:33:00	lightning in the area
NW-SD and NW-SD-DE 110kV	Reclass	05/11/14 12:30	05/11/14 16:05	3:35:00	Lightning about
NW-SD and NW-SD-DE 110kV	Reclass	27/10/14 06:00	27/10/14 06:40	0:40:00	Lightning
NW-SD and NW-SD-DE 110kV	Reclass	06/10/14 21:30	06/10/14 23:00	1:30:00	Lightning in Area
NW-SD and NW-SD-DE 110kV	Reclass	29/09/14 00:25	29/09/14 02:10	1:45:00	Lightning in Area
NW-SD and NW-SD-DE 110kV	Reclass	01/08/14 05:15	01/08/14 06:00	0:45:00	Lightning in the Area
NW-SD and NW-SD-DE 110kV	Reclass	29/07/14 09:30	29/07/14 10:05	0:35:00	Lightning in the area
NW-SD and NW-SD-DE 110kV	Reclass	25/07/14 14:38	25/07/14 15:30	0:52:00	Lightning in the area
NW-SD and NW-SD-DE 110kV	Reclass	19/05/14 21:15	19/05/14 21:45	0:30:00	Lightning
NW-SD and NW-SD-DE 110kV	Reclass	26/04/14 06:45	26/04/14 08:40	1:55:00	Lightning
NW-SD and NW-SD-DE 110kV	Reclass	22/04/14 05:10	22/04/14 06:00	0:50:00	Lightning
NW-SD and NW-SD-DE 110kV	Reclass	16/03/14 03:44	16/03/14 04:30	0:46:00	Lightning
NW-SD and NW-SD-DE 110kV	Reclass	11/03/14 20:08	11/03/14 21:11	1:03:00	Lightning in Area
NW-SD and NW-SD-DE 110kV	Reclass	05/03/14 04:10	05/03/14 05:00	0:50:00	Lightning in the Area
NW-SD and NW-SD-DE 110kV	Reclass	15/02/14 23:20	16/02/14 01:35	2:15:00	Lightning in area.
NW-SD and NW-SD-DE 110kV	Reclass	24/01/14 04:40	24/01/14 06:53	2:13:00	Lightning in area.
NW-SD and NW-SD-DE 110kV	Reclass	17/01/14 23:35	18/01/14 00:35	1:00:00	Lightning
NW-SD and NW-SD-DE 110kV	Reclass	17/01/14 18:00	17/01/14 18:55	0:55:00	Lightning
NW-SD and NW-SD-DE 110kV	Reclass	05/12/13 13:35	05/12/13 16:55	3:20:00	Lightning
NW-SD and NW-SD-DE 110kV	Reclass	04/12/13 09:35	04/12/13 11:45	2:10:00	Lightning

Appendix C: Lightning magnitude and frequency in the NW-SD-DE 110 kV transmission corridor

Figure 10 Negative lightning impulse in vicinity of the NW-SD-DE transmission corridor

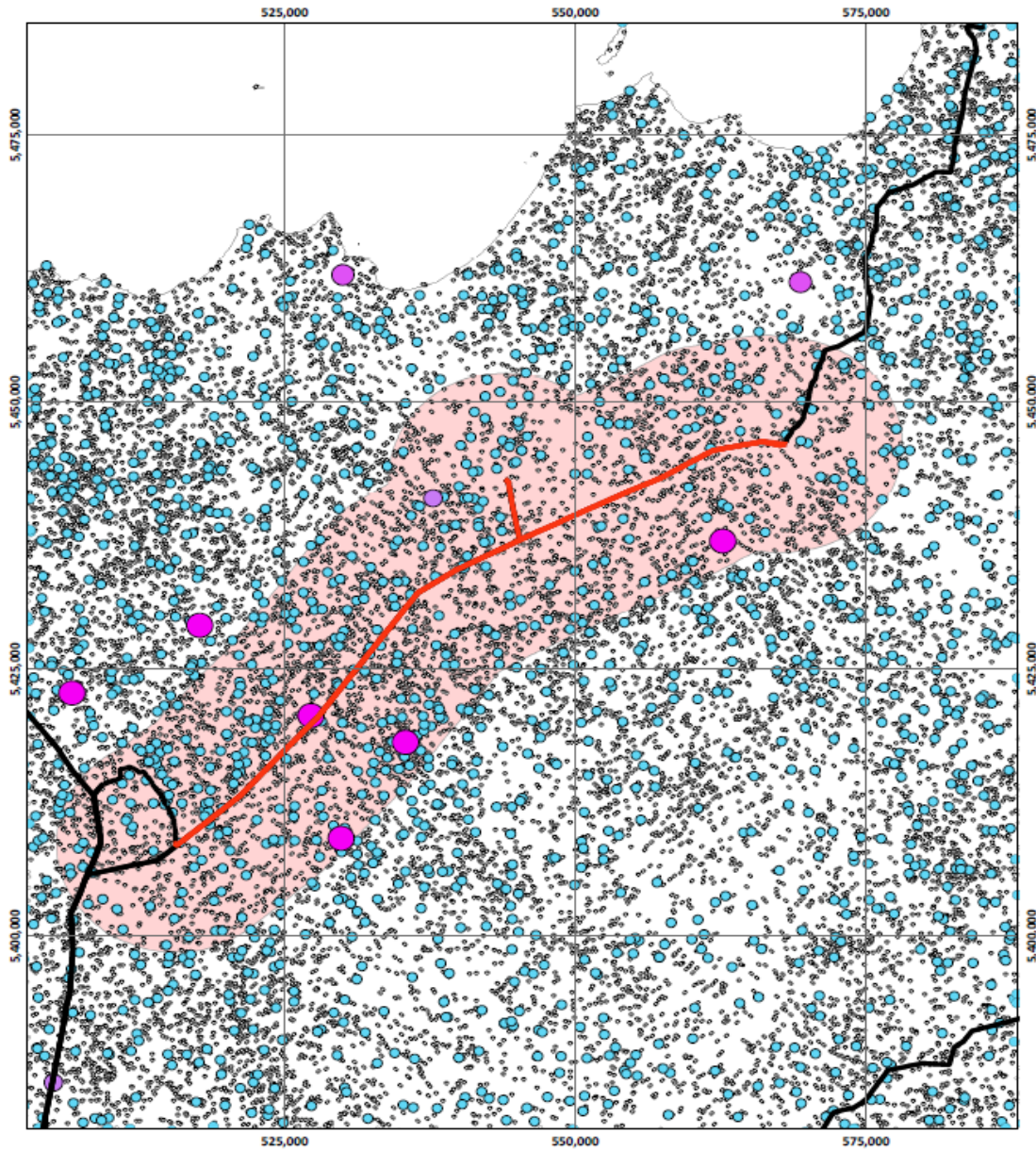

GPATs Lightning (May 2003 - May 2017)

<p>GPATS_0317_TAS_NEG</p> <ul style="list-style-type: none"> ● -506363 - -434037 ● -434036 - -361711 ● -361710 - -289385 ● -289384 - -217058 ● -217057 - -144732 ● -144731 - -5000 ● -4999 - -80 	<ul style="list-style-type: none"> — Area of Interest — OH Transmission Line 10km Buffer Zone 	<p>N</p> <p>Scale: 1:500,000</p> <p>0 5 10 km</p> <p>Coordinate System: GDA 1994 MGA Zone 55 Projection: Transverse Mercator Datum: GDA 1994</p> <p><small>TasNetworks has made every effort to ensure this product is free of errors but does not warrant the map or its features are either spatially or temporally accurate or fit for a particular use. TasNetworks provides this map without any warranty of any kind whatsoever, either express or implied.</small></p> <p>© TasNetworks 2016</p>	<p>Date: 2/08/2017 10:21:51 AM Prepared by: R.Mazurek</p> 
--	---	---	---

Document Path: I:\GIS_Projects\2016_17\SAW\170221_SAW_lightning_strike_Assess\OUTPU\170802_GPATS_lightning.mxd

Figure 11 Positive lightning impulse in vicinity of the NW-SD-DE transmission corridor

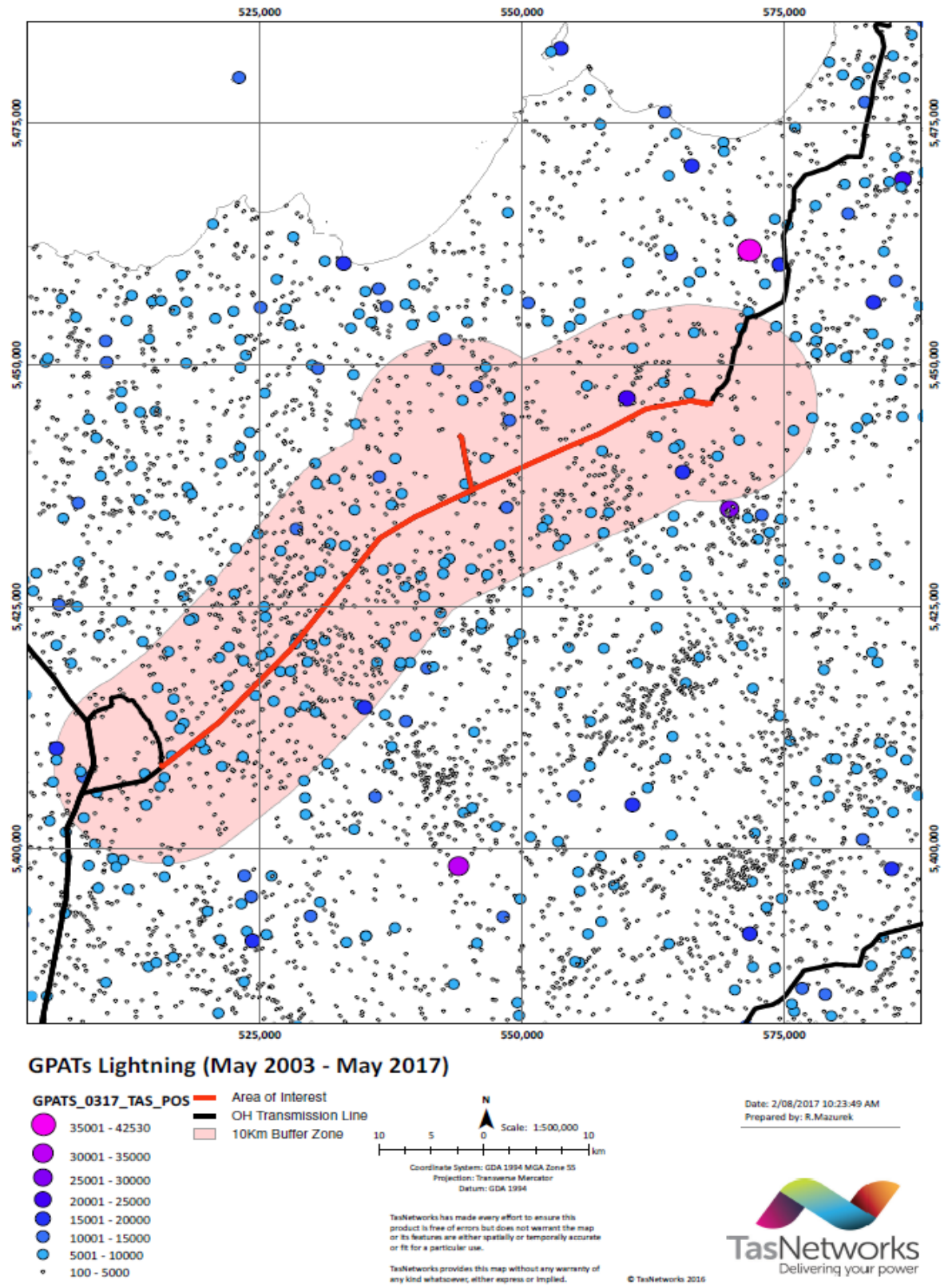

Appendix D: Lightning magnitude and frequency in the NW-SD-DE 110 kV transmission corridor

Global Position and Tracking Systems (GPATS) data for 13 years is shown graphically in Table 2 and Table 3 for negative and positive lightning strikes. The pink area represents a 10 km radius from the transmission line which is typical for changes in operation of transmission lines in lightning impacted areas. The frequencies of the negative and positive strike amplitudes are summaries in Table 2 and table 3 respectively.

Table 3 Frequency of negative strike amplitude

Lightning Amplitude (kA)	Frequency
0 - -5,000	3,920
-5001 - -10,000	327
-10,001 – -15,000	56
-15,001 – -20,000	11
-20,001 – -25,000	4
-25,001 – -30,000	1
-30,001 – -35,000	3
-35,001 – -40,000	0
-40,001 – -45,000	2
-45,001 – -50,000	2

Table 4 Frequency of positive strike amplitude

Lightning Amplitude (kA)	Frequency
0 - 5,000	827
5001 - 10,000	104
10,001 – 15,000	8
15,001 – 20,000	3
20,001 – 25,000	1

Table 5 Summary of fault outages

Count of Tertiary Cause	Secondary Cause				Grand Total
	Adverse Weather	Human Error During Planned Work	Protection Design / Calculations Incorrect	Unknown	
NW-SD 110 kV Transmission Circuit	12	2		1	15
NW-SD-DE 110 kV Transmission Circuit	8				8
Grand Total	20	2		1	23

Appendix E: Historical record of fault outage on the NW-SD-DE 110 kV transmission circuit

WASP Outage Key	Circuit Name	Circuit Voltage	Actual Open	Actual Close	Description	Interruption Type	Primary Cause	Secondary Cause	Tertiary Cause
11102	NW-SD 110 kV Transmission Circuit	110	18/06/2007 22:48	18/06/2007 22:48	IR435 - Norwood-Scottsdale-Derby 110 kV transmission circuit momentarily interrupted five times due to OPGW clashing with phase conductor in wind. Total outage duration approximately 2 minutes.	Fault	Environmental	Adverse Weather	Suspect Windborne Debris
11102	NW-SD 110 kV Transmission Circuit	110	19/06/2007 00:28	19/06/2007 00:28	IR435 - Norwood-Scottsdale-Derby 110 kV transmission circuit momentarily interrupted five times due to OPGW clashing with phase conductor in wind. Total outage duration approximately 2 minutes.	Fault	Environmental	Adverse Weather	Suspect Windborne Debris
11102	NW-SD 110 kV Transmission Circuit	110	19/06/2007 00:39	19/06/2007 00:39	IR435 - Norwood-Scottsdale-Derby 110 kV transmission circuit momentarily interrupted five times due to OPGW clashing with phase conductor in wind. Total outage duration approximately 2 minutes.	Fault	Environmental	Adverse Weather	Suspect Windborne Debris
11102	NW-SD 110 kV Transmission Circuit	110	19/06/2007 00:41	19/06/2007 00:41	IR435 - Norwood-Scottsdale-Derby 110 kV transmission circuit momentarily interrupted five times due to OPGW clashing with phase conductor in wind. Total outage duration approximately 2 minutes.	Fault	Environmental	Adverse Weather	Suspect Windborne Debris
11102	NW-SD 110 kV Transmission Circuit	110	19/06/2007 00:43	19/06/2007 00:43	IR435 - Norwood-Scottsdale-Derby 110 kV transmission circuit momentarily interrupted five times due to OPGW clashing with phase conductor in wind. Total outage duration approximately 2 minutes.	Fault	Environmental	Adverse Weather	Suspect Windborne Debris
11332	NW-SD-DE 110 kV Transmission Circuit	110	09/08/2007 21:51	09/08/2007 22:00	IR453 - Norwood-Scottsdale-Derby 110 kV transmission circuit interrupted during severe weather. Total outage duration 17 minutes.	Fault	Environmental	Adverse Weather	Suspect Lightning
11332	NW-SD-DE 110 kV Transmission Circuit	110	09/08/2007 23:53	09/08/2007 23:57	IR453 - Norwood-Scottsdale-Derby 110 kV transmission circuit interrupted during severe weather. Total outage duration 17 minutes.	Fault	Environmental	Adverse Weather	Suspect Lightning
11332	NW-SD-DE 110 kV Transmission Circuit	110	10/08/2007 08:57	10/08/2007 09:01	IR453 - Norwood-Scottsdale-Derby 110 kV transmission circuit interrupted during severe weather. Total outage duration 17 minutes.	Fault	Environmental	Adverse Weather	Suspect Lightning

WASP Outage Key	Circuit Name	Circuit Voltage	Actual Open	Actual Close	Description	Interruption Type	Primary Cause	Secondary Cause	Tertiary Cause
11336	NW-SD 110 kV Transmission Circuit	110	18/08/2007 10:13	18/08/2007 10:30	IR458 - Scottsdale Substation transformer T2 interrupted twice due to inadvertent circuit breaker trip during planned maintenance. Total outage duration 24 minutes.	Fault	Operational	Human Error During Planned Work	Maintenance Error
11336	NW-SD 110 kV Transmission Circuit	110	18/08/2007 12:32	18/08/2007 12:39	IR458 - Scottsdale Substation transformer T2 interrupted twice due to inadvertent circuit breaker trip during planned maintenance. Total outage duration 24 minutes.	Fault	Operational	Human Error During Planned Work	Maintenance Error
17986	NW-SD 110 kV Transmission Circuit	110	03/04/2009 13:12	03/04/2009 13:12	IR797 NW-SD-DE tripped and auto-reclose, lightning in area.	Fault	Environmental	Adverse Weather	Suspect Lightning
28119	NW-SD 110 kV Transmission Circuit	110	30/11/2012 04:12	30/11/2012 04:15	IR1181 NW-SD 110 kV transmission circuit tripped due to unknown cause.	Fault	Unknown	Unknown	Unknown
29625	NW-SD-DE 110 kV Transmission Circuit	110	06/06/2013 06:31	06/06/2013 06:37	IR1330 Scottsdale A152 tripped due incorrect zone 3 reach in protection relays	Fault	Operational	Protection Design / Calculations Incorrect	
30791	NW-SD 110 kV Transmission Circuit	110	23/11/2013 12:48	23/11/2013 12:48	IR1504 NW-SD, NW-SD-DE and DE-MR 110 kV transmission circuits tripped with lightning in area.	Fault	Environmental	Adverse Weather	Lightning
30791	NW-SD-DE 110 kV Transmission Circuit	110	23/11/2013 12:48	23/11/2013 12:48	IR1504 NW-SD, NW-SD-DE and DE-MR 110 kV transmission circuits tripped with lightning in area.	Fault	Environmental	Adverse Weather	Lightning
31171	NW-SD-DE 110 kV Transmission Circuit	110	24/01/2014 05:21	24/01/2014 05:32	IR1559 NW-SD-DE, NW-SD and MR-DE 110 kV transmission line circuits tripped and auto reclosed with lightning in the area and with no loss of supply.	Fault	Environmental	Adverse Weather	Lightning
31171	NW-SD 110 kV Transmission Circuit	110	24/01/2014 05:21	24/01/2014 05:21	IR1559 NW-SD-DE, NW-SD and MR-DE 110 kV transmission line circuits tripped and auto reclosed with lightning in the area and with no loss of supply.	Fault	Environmental	Adverse Weather	Suspect Lightning
33675	NW-SD 110 kV Transmission Circuit	110	05/05/2015 10:54	05/05/2015 10:54	IR? NW-SD 110 kV transmission circuit tripped, auto-reclosed and then tripped out again during severe weather.	Fault	Environmental	Adverse Weather	Lightning
33675	NW-SD 110 kV Transmission Circuit	110	05/05/2015 11:00	05/05/2015 16:48	IR? NW-SD 110 kV transmission circuit tripped, auto-reclosed and then tripped out again during severe weather.	Fault	Environmental	Adverse Weather	Lightning
35644	NW-SD-DE 110 kV Transmission Circuit	110	18/10/2016 15:55	18/10/2016 15:55	IR2152 NW-SD-DE 110 kV transmission line tripped and auto reclosed, with loss of Musselroe wind farm.	Fault	Environmental	Adverse Weather	Lightning

WASP Outage Key	Circuit Name	Circuit Voltage	Actual Open	Actual Close	Description	Interruption Type	Primary Cause	Secondary Cause	Tertiary Cause
35916	NW-SD-DE 110 kV Transmission Circuit	110	30/12/2016 03:22	30/12/2016 03:22	IR2167 NW-SD 110 kV and NW-SD-DE 110 kV transmission circuit tripped and auto reclosed due to lightning in close proximity of transmission circuit. Load shed 19 MW at MIs. MR wind farm 4 MW dropped.	Fault	Environmental	Adverse Weather	Lightning
35916	NW-SD 110 kV Transmission Circuit	110	30/12/2016 03:22	30/12/2016 03:22	IR2167 NW-SD 110 kV and NW-SD-DE 110 kV transmission circuit tripped and auto reclosed due to lightning in close proximity of transmission circuit. Load shed 19 MW at MIs. MR wind farm 4 MW dropped.	Fault	Environmental	Adverse Weather	Lightning
36242	NW-SD 110 kV Transmission Circuit	110	26/03/2017 05:17	26/03/2017 05:17	IR2177 NW-SD 110 kV transmission circuit tripped and auto reclosed, pending investigation.	Fault	Environmental	Adverse Weather	Lightning
36784	NW-SD-DE 110 kV Transmission Circuit	110	11/08/2017 21:48	11/08/2017 22:04	IR2197 NW-SD-DE 110 kV transmission circuit tripped with lightning in area, also with DE-MR 110 kV transmission circuit.	Fault	Environmental	Adverse Weather	Lightning